

MAX6633/MAX6634/ MAX6635

12-Bit Plus Sign Temperature Sensors with SMBus/I²C-Compatible Serial Interface

General Description

The MAX6633/MAX6634/MAX6635 combine a temperature sensor, a programmable overtemperature alarm, and an SMBus/I²C-compatible serial interface into a single package. They convert their die temperatures into digital values using internal analog-to-digital converters (ADCs). The result of the conversion is then held in a temperature register as a 12-bit + sign value, allowing 0.0625°C resolution, readable at any time through the serial interface. The devices are capable of reading temperatures up to +150°C.

The MAX6633/MAX6634/MAX6635 feature a shutdown mode that saves power by turning off everything except the power-on reset (POR) and the serial interface. The devices can be configured to separate addresses, allowing multiple devices to be used on the same bus.

The MAX6633 has four address pins, allowing up to 16 devices to be connected to a single bus. The MAX6634 has three address pins, allowing up to eight devices to be connected to a single bus. The MAX6635 has two address pins, allowing up to four devices to be connected to a single bus.

The MAX6633/MAX6634/MAX6635 make temperature data available for transfer over the serial interface. The MAX6634 incorporates a dual-mode ALERT output (open drain) and can serve as an upgraded alternative to the LM75. The MAX6635 includes an ALERT output and an OVERT output (both open drain) and can function as an upgraded replacement for the LM76 in most applications. The MAX6634/MAX6635 feature user-programmable temperature thresholds. All three devices come in an 8-pin SO package.

Applications

- Battery Temperature Alarms
- PC Temperature Control

Pin Configurations appear at end of data sheet.

Features

- +3V to +5.5V Supply Range
- Accuracy
 - ±1°C max (0°C to +50°C)
 - ±1.5°C max (-20°C to +85°C)
 - ±2.5°C max (-40°C to +125°C)
 - ±2.5°C typ (+150°C)
- User-Programmable Temperature Thresholds (MAX6634/MAX6635)
- User-Configurable Alarm Output(s) (MAX6634/MAX6635)
- Ability to Respond to SMBus/I²C-Compatible Alert Response Address (MAX6634/MAX6635)
- OVERT Output for System Shutdown (MAX6635)
- Multiple Devices per Bus
 - 16 devices (MAX6633)
 - 8 devices (MAX6634)
 - 4 devices (MAX6635)

Ordering Information

PART	TEMP. RANGE	PIN-PACKAGE
MAX6633MSA	-55°C to +150°C	8 SO
MAX6634MSA	-55°C to +150°C	8 SO
MAX6635MSA	-55°C to +150°C	8 SO

Typical Operating Circuit

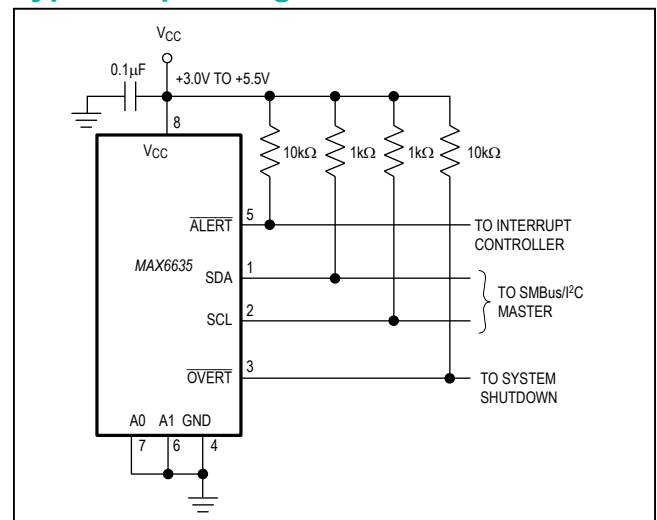

Absolute Maximum Ratings

V _{CC} , SDA, SCL	-0.3V to +6.0V	Junction Temperature	+150°C
All Other Pins	-0.3V to V _{CC} +0.3V	Operating Temperature Range	-55°C to +150°C
SDA, ALERT, OVERT Current	-1mA to +50mA	Storage Temperature Range	-65°C to +150°C
ESD Protection (Human Body Model)	2000V	Lead Temperature (soldering, 10s)	+300°C
Continuous Power Dissipation (T _A = +70°C) 8-Pin SO (derate 5.88mW/°C above +70°C)	471mW		

Stresses beyond those listed under "Absolute Maximum Ratings" may cause permanent damage to the device. These are stress ratings only, and functional operation of the device at these or any other conditions beyond those indicated in the operational sections of the specifications is not implied. Exposure to absolute maximum rating conditions for extended periods may affect device reliability.

Electrical Characteristics

(V_{CC} = +3.0V to +5.5V, T_A = -55°C to +125°C, unless otherwise noted. Typical values are V_{CC} = +3.3V, T_A = +25°C, unless otherwise noted.)

PARAMETER	SYMBOL	CONDITIONS	MIN	TYP	MAX	UNITS
TEMPERATURE-TO-DIGITAL CONVERTER CHARACTERISTICS						
Supply Range	V _{CC}		3.0		5.5	V
Accuracy (Note 1)		0°C ≤ T _A ≤ +50°C, V _{CC} = +3.3V	-1.0	±0.4	+1.0	°C
		-20°C ≤ T _A ≤ +85°C, V _{CC} = +3.3V	-1.5	±0.6	+1.5	
		-40°C ≤ T _A ≤ +125°C, V _{CC} = +3.3V	-2.5	±1.0	+2.5	
		T _A = -55°C, V _{CC} = +3.3V	-2.8	±1.5	+2.8	
		T _A = +150°C, V _{CC} = +3.3V		±2.5		
Power-Supply Rejection Ratio	PSRR			0.2	0.5	°C/V
POR Threshold Hysteresis				90		mV
Supply Current in Shutdown		V _{CC} = +3.0V, SMBus inactive		12	20	µA
		V _{CC} = +5.5V, SMBus inactive		20	30	
Average Operating Current		V _{CC} = +3.0V, SMBus inactive		150		µA
		V _{CC} = +5.5V, SMBus inactive		200		
Peak Operating Current (Note 2)		V _{CC} = +3.0V, SMBus inactive		270	350	µA
		V _{CC} = +5.5V, SMBus inactive		350	700	
Conversion Rate			1.4	2	2.4	Hz
DIGITAL INTERFACE						
Logic Input Low Voltage	V _{IL}	V _{CC} = +3.0V to +5.5V			0.65	V
Logic Input High Voltage	V _{IH}	V _{CC} = +3V	2.2			V
		V _{CC} = +5.5V	2.4			
Input Leakage Current	I _{LLEAK}	V _{IN} = GND or V _{CC}			±1	µA
Output Low Sink Current	I _{OL}	V _{OL} = 0.6V (SMBDATA, ALERT, OVERT)	6			mA
Output Leakage Current	I _{O_LEAK}	ALERT, OVERT at V _{CC}			±1	µA
Input Capacitance	C _{IN}			5		pF

Electrical Characteristics (continued)

(V_{CC} = +3.0V to +5.5V, T_A = -55°C to +125°C, unless otherwise noted. Typical values are V_{CC} = +3.3V, T_A = +25°C, unless otherwise noted.)

PARAMETER	SYMBOL	CONDITIONS	MIN	TYP	MAX	UNITS
SMBus TIMING (Note 3) (Figures 1, 2, and 3)						
Serial Clock Frequency	f _{SCL}		10		100	kHz
Bus Free Time Between STOP and START Condition	t _{BUF}		4.7			μs
START Condition Setup Time			4.7			μs
Repeat START Condition Setup Time	t _{SU:STA}	90% to 90%	4.7			μs
START Condition Hold Time	t _{HD:STA}	10% of SMBDATA to 90% of SMBCLK	4			μs
STOP Condition Setup Time	t _{SU:STO}	90% of SMBCLK to 10% of SMBDATA	4			μs
Data Setup Time	t _{SU:DAT}	90% of SMBDATA to 10% of SMBCLK	250			ns
Data Hold Time (Note 4)	t _{HD:DAT}		300			ns
Receive SCL/SDA Rise Time	t _R				1	μs
SCL/SDA Fall Time (Note 4)	t _F				300	ns
Clock Low Period	t _{LOW}	10% to 10%	4.7			μs
Clock High Period	t _{HIGH}	90% to 90%	4			μs
SMBus Timeout			25		48	ms

Note 1: Guaranteed by design and characterization.

Note 2: Peak operating current measured during conversion. See Figure 4.

Note 3: Guaranteed by design, not production tested.

Note 4: A master device must provide a hold time of at least 300ns for the SDA signal in order to bridge the undefined region of SCL's falling edge.

Typical Operating Characteristics

(V_{CC} = +3.3V, T_A = +25°C, unless otherwise noted.)

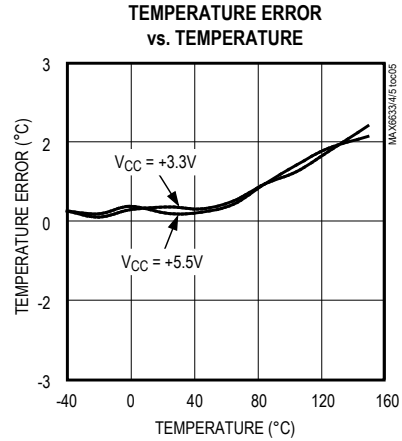
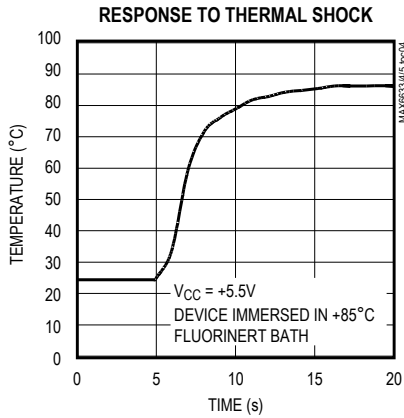
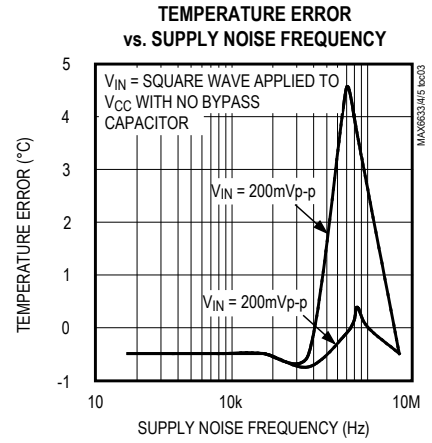
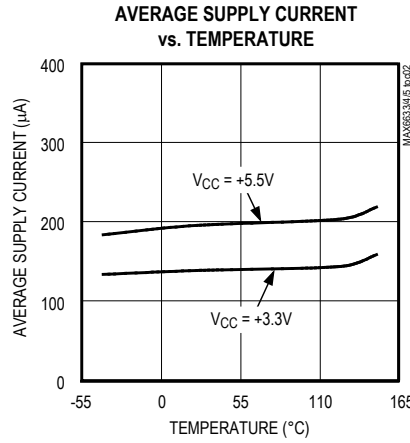
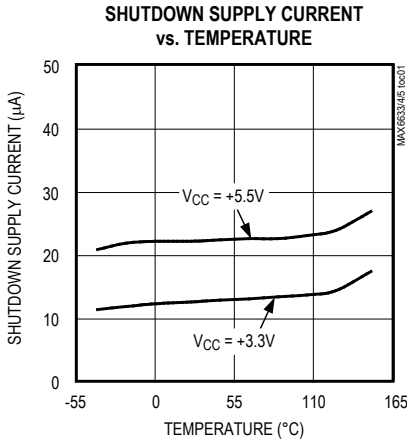

Pin Description

PIN			NAME	FUNCTION
MAX6633	MAX6634	MAX6635		
1	1	1	SDA	Serial Data Input/Output. Open drain.
2	2	2	SCL	Serial Clock Input
3	—	—	A3	Address Pin
4	4	4	GND	Ground
5	5	—	A2	Address Pin
6	6	6	A1	Address Pin
7	7	7	A0	Address Pin
8	8	8	V _{CC}	Supply Voltage Input. +3.0V to +5.5V. Bypass V _{CC} to GND with a 0.1µF capacitor.
—	3	5	$\overline{\text{ALERT}}$	$\overline{\text{ALERT}}$ Output. Open drain.
—	—	3	$\overline{\text{OVERT}}$	$\overline{\text{OVERT}}$ Output. Open drain.

Detailed Description

The MAX6633/MAX6634/MAX6635 continuously convert their die temperatures into digital values using their integrated ADCs. The resulting data is readable at any time through the SMBus/I²C-compatible serial interface. The device functions as a slave on the SMBus interface, supporting Write Byte, Write Word, Read Byte, and Read Word commands. Separate addresses can be configured using the individual address pins. Figures 5, 6, and 7 show the functional diagrams of the MAX6633/MAX6634/MAX6635, respectively.

SMBus/I²C-Compatible Operation

The MAX6633/MAX6634/MAX6635 are readable and programmable through their SMBus/I²C-compatible serial interface. Figures 1, 2, and 3 show the timing details of the clock (SCL) and data (SDA) signals. The devices function as slaves on the SMBus and support Write Byte, Write Word, Read Byte, and Read Word commands. Figure 8 is the MAX6633/MAX6634/MAX6635 programmer's model.

Addressing

Separate addresses can be configured using the individual address pins. The address of each device is selected by connecting the address (A_n) pins to one of two potentials: GND or V_{CC}. The MAX6635 makes two address pins available (A0, A1), allowing up to four devices to be connected to a single bus line. The MAX6634 makes three address pins available (A0, A1, A2), allowing up to eight devices to be connected to a single bus line. The MAX6633 makes four address pins available (A0, A1, A2, A3), allowing as many as 16

devices to be connected to a single bus line. Table 1 shows the full SMBus/I²C address for each device type.

Control Registers (MAX6633)

Three registers control the operation of the MAX6633 (Figure 5 and Tables 2 through 6). The Pointer register is the first addressed and determines which of the other two registers is acted upon. The other two are the Temperature and Configuration registers. The temperature value is stored as 12 bits plus a sign bit, read only, and contains the latest temperature data. The true register length is 16 bits, with the lower 3 unused in this part. The digital temperature data contained in the temperature register is in °C, using a two's-complement format with 1 LSB corresponding to 0.0625°C.

The Configuration register is 8 bits, read/write, and contains the SMBus timeout disable bit, fault queue enable bit, and the shutdown bit.

Control Registers (MAX6634)

Six registers control the operation of the MAX6634 (Figure 6 and Tables 2 through 7). The pointer register is the first addressed and determines which of the other five registers is acted upon. The other five are the Temperature, Configuration, High-Temperature (T_{HIGH}), Low-Temperature (T_{LOW}), and Hysteresis (T_{HYST}) registers. The temperature value is stored as 12 bits plus a sign bit, read only, and contains the latest temperature data. The true register length is 16 bits, with the lowest 2 used as status bits, and the third bit (D2) is unused. The digital temperature data contained in the temperature register is in °C, using a two's-complement format with 1 LSB corresponding to 0.0625°C.

Write Byte Format														
S	ADDRESS	WR	ACK	COMMAND	ACK	DATA	ACK	P						
	7 bits			8 bits		8 bits								
Slave Address: equivalent to chip-select line of a 3-wire interface			Command Byte: selects register you are writing to			Data Byte: data goes into the register set by the command byte								
Write Word Format														
S	ADDRESS	WR	ACK	COMMAND	ACK	DATA	ACK	DATA	ACK	P				
	7 bits			8 bits		8 bits (MSB)		8 bits (LSB)						
Slave Address: equivalent to chip-select line of a 3-wire interface			Command Byte: selects register you are writing to			Data Bytes: data goes into the register set by the command byte								
Read Byte Format														
S	ADDRESS	WR	ACK	COMMAND	ACK	S	ADDRESS	RD	ACK	DATA	///	P		
	7 bits			8 bits			7 bits			8 bits				
Slave Address: equivalent to chip-select line			Command Byte: selects register you are reading from			Slave Address: repeated due to change in data-flow direction			Data Byte: reads from the register set by the command byte					
Read Word Format														
S	ADDRESS	WR	ACK	COMMAND	ACK	S	ADDRESS	RD	ACK	DATA	ACK	DATA	///	P
	7 bits			8 bits			7 bits			8 bits (MSB)		8 bits (LSB)		
Slave Address: equivalent to chip-select line			Command Byte: selects register you are reading from			Slave Address: repeated due to change in data-flow direction			Data Bytes: reads from the register set by the command byte					
S = Start condition			Shaded = Slave transmission											
P = Stop condition			/// = Not acknowledged											

Figure 1. SMBus Protocols

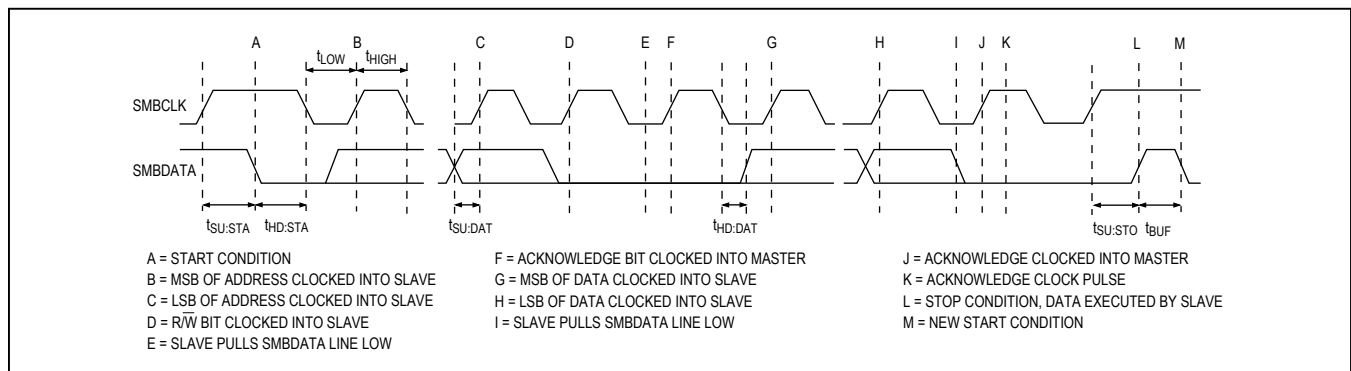

Figure 2. SMBus Write Timing Diagram

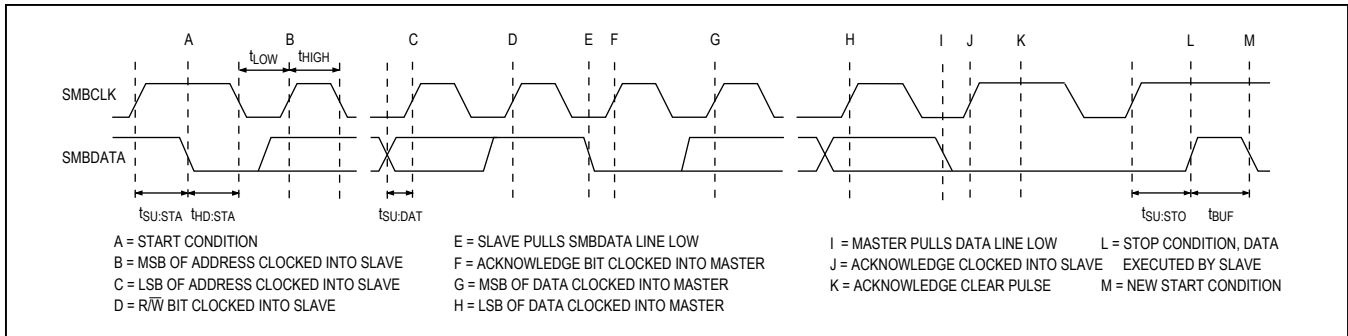

Figure 3. SMBus Read Timing Diagram

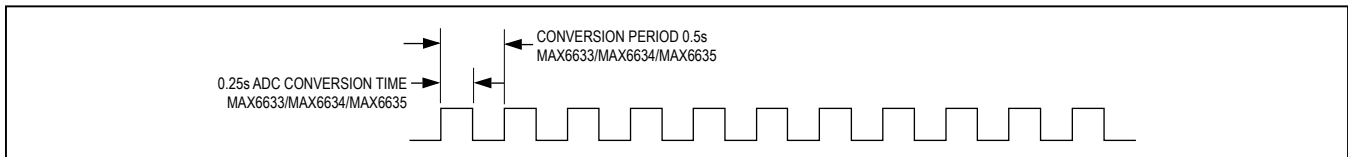

Figure 4. ADC Conversion Timing Diagram

The Configuration register is 8 bits, read/write, and contains the SMBus timeout disable bit, fault queue enable bit, the temperature alarm output polarity select bits, the interrupt mode select bit, and the shutdown bit. Registers T_{HIGH} and T_{LOW} are 16 bits, read/write, and contain the values that trigger \overline{ALERT} . Register T_{HYST} is 16 bits, read/write, and contains the values by which the temperature must rise or fall beyond T_{HIGH} or T_{LOW} , before \overline{ALERT} deasserts.

Control Registers (MAX6635)

Seven registers control the operation of the MAX6635 (Figure 7 and Tables 2 through 7). The Pointer register is the first addressed and determines which of the other six registers is acted upon. The other six are the Temperature, Configuration, High-Temperature (T_{HIGH}), Low-Temperature (T_{LOW}), Maximum Temperature (T_{MAX}), and Hysteresis (T_{HYST}) registers. The temperature value is stored as 12 bits plus a sign bit, read only, and contains the latest temperature data. The true register length is 16 bits, with the lower three used as status bits. The digital temperature data contained in the temperature register is in $^{\circ}C$, using a two's-complement format with 1 LSB corresponding to $0.0625^{\circ}C$.

The configuration register is 8 bits, read/write, and contains the SMBus timeout disable bit, fault queue enable bit, the temperature alarm output polarity select bits, the interrupt mode select bit, and the shutdown

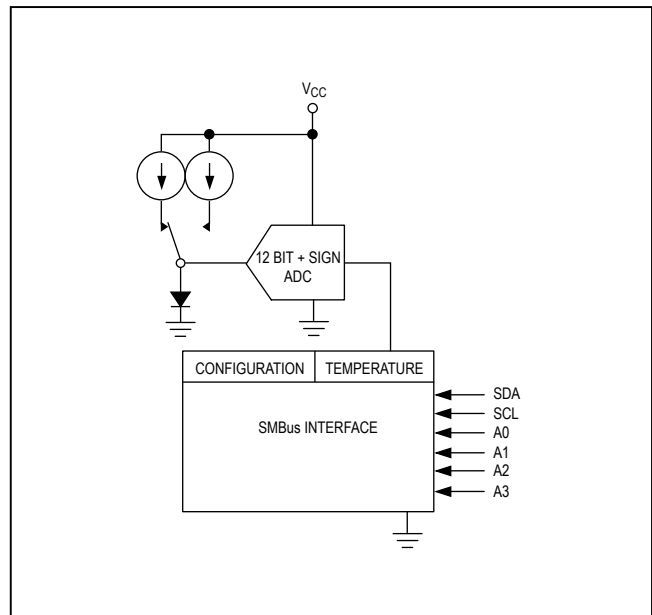

Figure 5. MAX6633 Functional Diagram

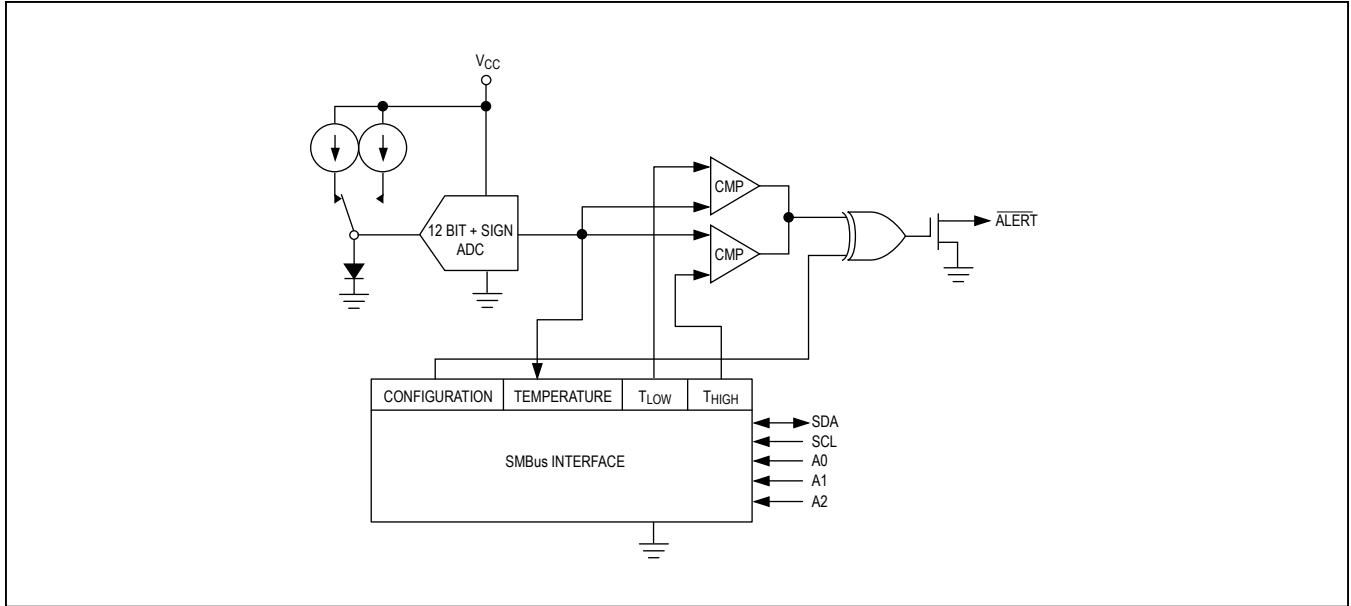

Figure 6. MAX6634 Functional Diagram

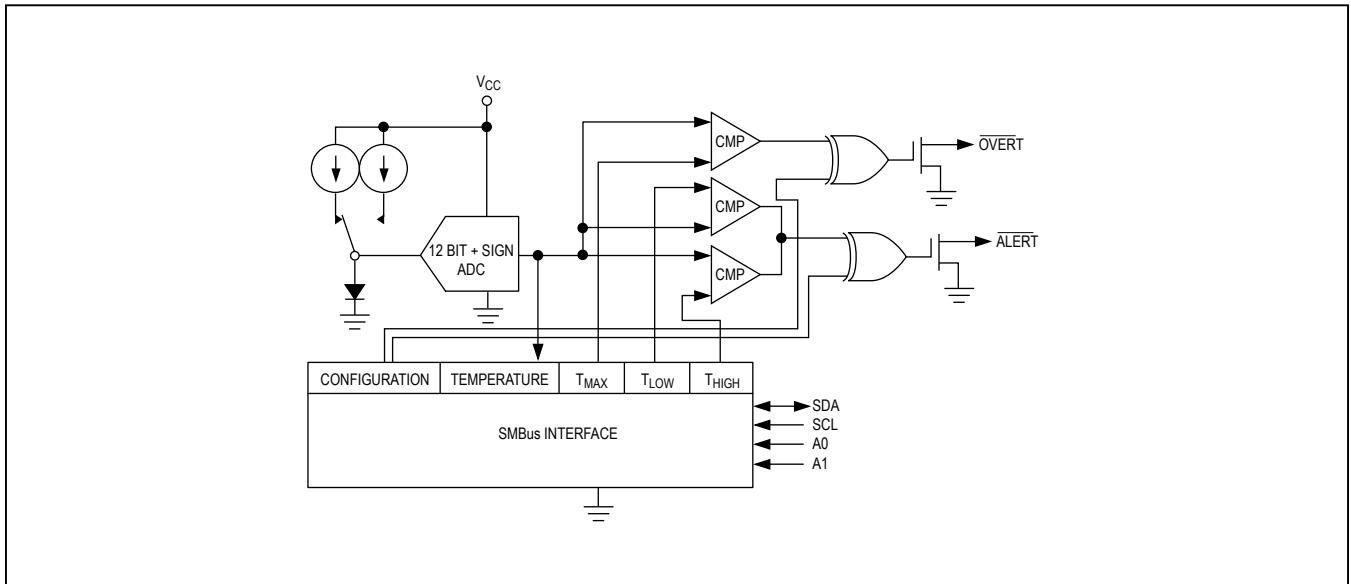

Figure 7. MAX6635 Functional Diagram

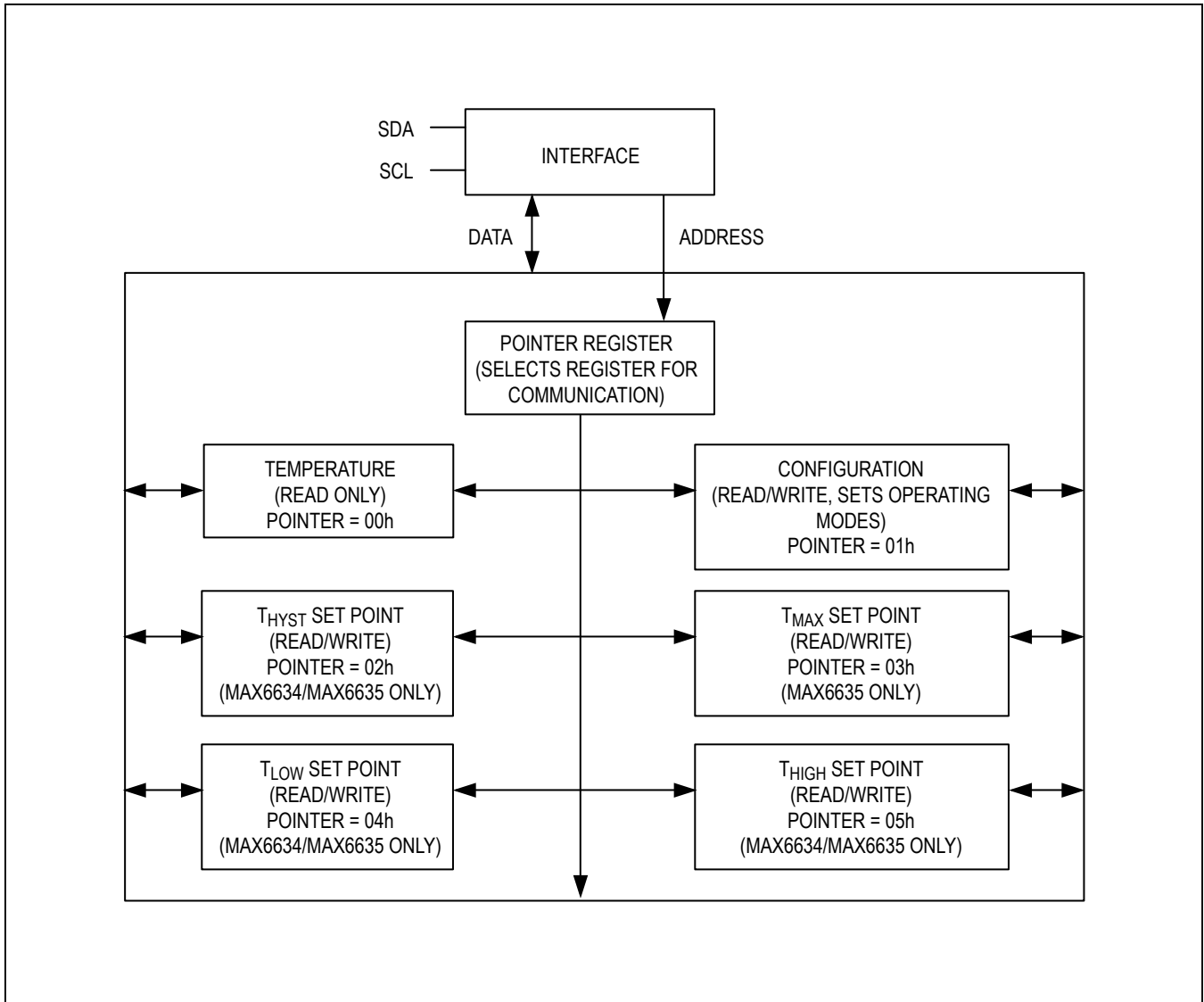

Figure 8. MAX6633/MAX6634/MAX6635 Programmer's Model

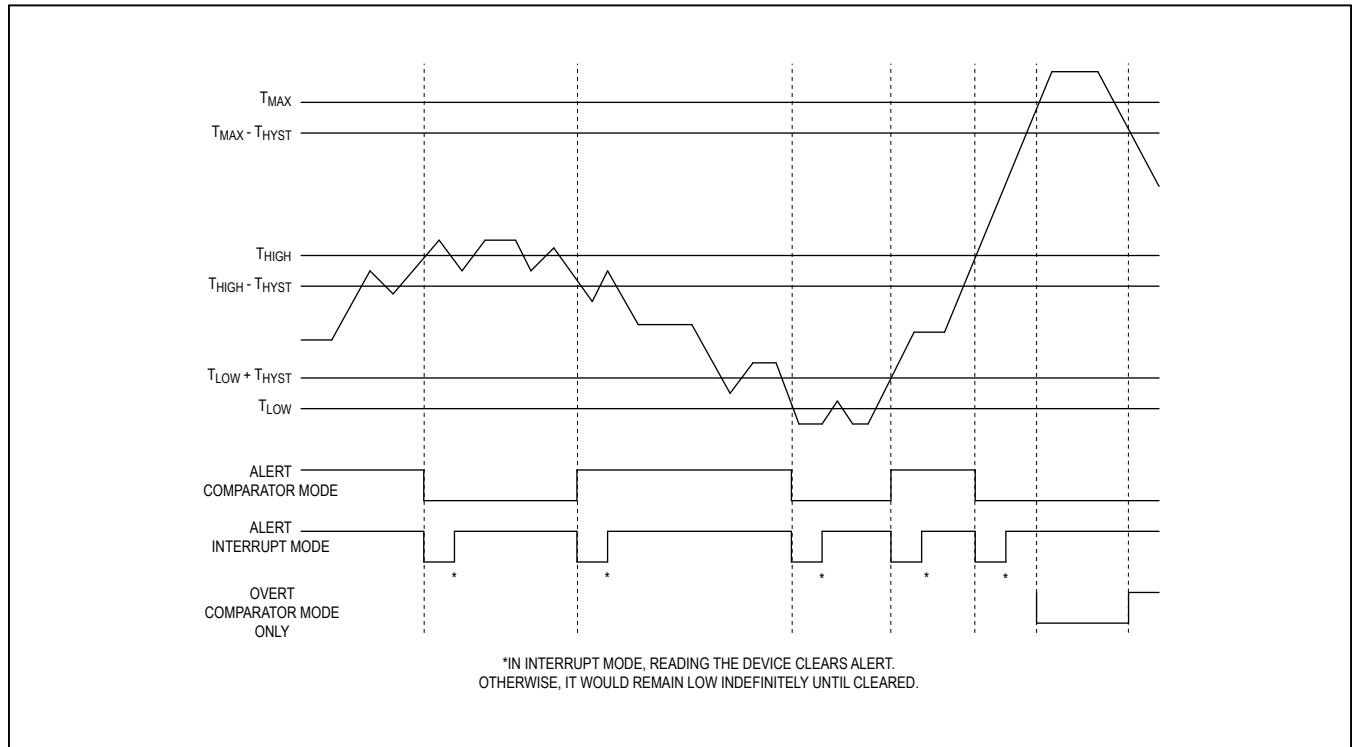

Figure 9. Alarm Output and Reset Diagram

bit. Registers T_{HIGH} and T_{LOW} are 16 bits, read/write, and contain values that trigger \overline{ALERT} and \overline{OVERT} . Register T_{HYST} is 16 bits, read/write, and contains the values by which the temperature must rise or fall beyond T_{HIGH} , T_{LOW} , or T_{MAX} , before \overline{ALERT} or \overline{OVERT} deassert.

Temperature Conversion

An on-chip bandgap reference produces a signal proportional to absolute temperature (PTAT), as well as the temperature-stable reference voltage necessary for the analog-to-digital conversion. The PTAT signal is digitized by the on-board ADC to a resolution of 0.0625°C. The resulting digital value is placed in the Temperature register. The temperature conversion runs continuously and asynchronously from the serial interface at a rate of 500ms per conversion. When the Temperature register is read, the conversion in progress is aborted. The bus transaction is completed by a stop condition.

Fault Queue (MAX6634/MAX6635)

A programmable fault queue on the MAX6634/MAX6635 eliminates spurious alarm activity in noisy environments. The queue sets the number of consecutive out-of-tolerance temperature readings that must occur before the \overline{ALERT} or \overline{OVERT} alarm outputs are toggled. An out-of-tolerance reading is above T_{HIGH} or T_{MAX} or below T_{LOW} . The fault queue depth defaults to 1 at power-up and may be programmed—through the configuration register—to four consecutive conversions. Any time the conversion result is in tolerance, and the particular alarm output is not asserted, the queue is cleared, even if it contains some out-of-tolerance counts. Additionally, the fault queue automatically clears at power-up and in shutdown. Whenever the fault queue is cleared, the alarm outputs are deasserted. Figure 9 is the alarm output and reset diagram.

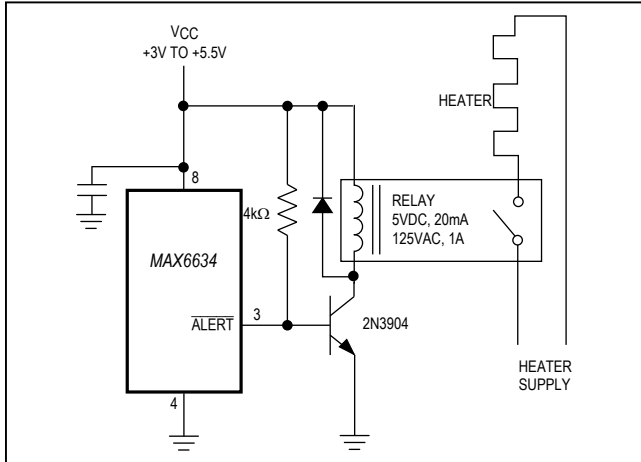

Figure 10. Simple Thermostat

Temperature Alert (MAX6634/MAX6635)

$\overline{\text{ALERT}}$ has programmable polarity and two modes: comparator and interrupt. Polarity and mode are selected through the Configuration register (Table 4). The $\overline{\text{ALERT}}$ output is open drain.

Interrupt Mode

With $\overline{\text{ALERT}}$ in interrupt mode, the MAX6634/MAX6635 look for a T_{HIGH} or a T_{LOW} fault. The $\overline{\text{ALERT}}$ pin asserts an alarm for an undertemperature fault, as well as for an overtemperature fault. Once either fault has occurred, it remains active until deasserted by a read of any register. The device then begins to look for a temperature change crossing the hysteresis level. The activation of $\overline{\text{ALERT}}$ is subject to the depth of the fault queue.

For example: If T_{HIGH} is set to 100°C, T_{HYST} is set to 20°C, and the fault queue depth is set to 4, $\overline{\text{ALERT}}$ does not assert until four consecutive conversions exceed 100°C. If the temperature is then read through the I²C-compatible interface, $\overline{\text{ALERT}}$ deasserts. $\overline{\text{ALERT}}$ asserts again when four consecutive conversions are less than 80°C.

Comparator Mode

In comparator mode, $\overline{\text{ALERT}}$ is asserted when the number of consecutive conversions exceeding the value in the T_{HIGH} register, or lower than the value in the T_{LOW} register, is equal to the depth of the fault queue. $\overline{\text{ALERT}}$ deasserts when the number of consecutive conversions

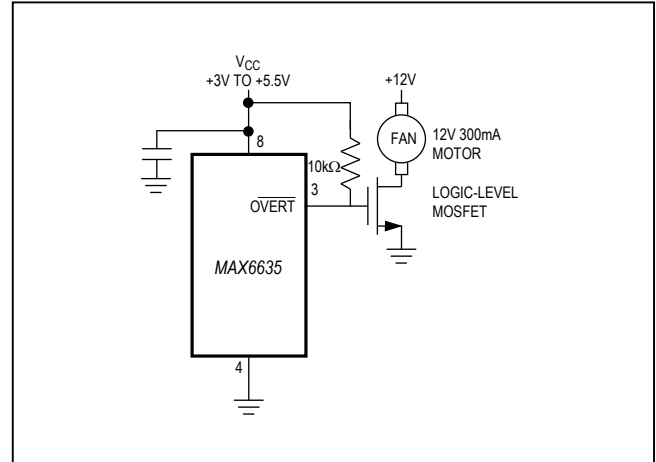

Figure 11. Fan Controller

less than $T_{\text{HIGH}} - T_{\text{HYST}}$ or greater than $T_{\text{LOW}} + T_{\text{HYST}}$ is equal to the depth of the fault queue.

For example: If T_{HIGH} is set to 100°C, T_{LOW} is set to 80°C, and the fault queue depth is set to four, $\overline{\text{ALERT}}$ does not assert until four consecutive conversions exceed 100°C, or are below 80°C. $\overline{\text{ALERT}}$ only deasserts if four consecutive conversions are less than $T_{\text{HIGH}} - T_{\text{HYST}}$ or greater than $T_{\text{LOW}} + T_{\text{HYST}}$.

Comparator mode allows autonomous clearing of an $\overline{\text{ALERT}}$ fault without the intervention of a master and is ideal to use for driving a thermostat (Figure 10).

Overtemperature Alarm (MAX6635)

The MAX6635 also includes an overtemperature output that is always in comparator mode. Whenever the temperature exceeds a value in the programmable T_{MAX} register, $\overline{\text{OVERT}}$ is asserted. $\overline{\text{OVERT}}$ only deasserts after the temperature drops below $T_{\text{MAX}} - T_{\text{HYST}}$. When the fault queue is activated, $\overline{\text{OVERT}}$ is subject to that queue, which sets the number of faults that must occur before $\overline{\text{OVERT}}$ asserts or deasserts. This helps prevent spurious alarms in noisy environments.

Comparator mode also allows autonomous clearing of an $\overline{\text{OVERT}}$ fault without the intervention of a master and thus is ideal to use for driving a cooling fan (Figure 11). In this application, the polarity of $\overline{\text{OVERT}}$ is active high.

Shutdown

The MAX6633/MAX6634/MAX6635 feature a shutdown mode, accessible through the serial interface that saves power by turning off everything except the POR

and the serial interface. Enter shutdown by programming the shutdown bit of the configuration register high. While in shutdown, the temperature register retains the last conversion result and can be read at any time. The ADC is turned off, reducing the device current draw to 30µA (max). The outputs of $\overline{\text{ALERT}}$ and $\overline{\text{OVERT}}$ are latched upon entering shutdown, and the fault queue is held in reset. After coming out of shutdown, the temperature register continues to read the last converted temperature, until the next conversion result is available.

Thermal Considerations

The MAX6633/MAX6634/MAX6635 supply current is typically 200µA when the serial interface is inactive. When used to drive high-impedance loads, the devices dissipate negligible power; therefore, the die temperature is essentially the same as the package temperature. The key to accurate temperature monitoring is good thermal contact between the MAX6633/MAX6634/MAX6635 package and the monitored device or circuit. Heat flows in and out of plastic packages primarily through the leads. Short, wide copper traces leading to the temperature monitor ensure that heat transfers quickly and reliably. The rise in die temperature due to self-heating is given by the following formula:

$$\Delta T_J = P_{\text{DISSIPATION}} \times \theta_{JA}$$

where $P_{\text{DISSIPATION}}$ is the power dissipated by the MAX6633/MAX6634/MAX6635, and θ_{JA} is the package's thermal resistance.

The typical thermal resistance is 170°C/W for the 8-pin SO package. To limit the effects of self-heating, minimize the output currents. For example, if the MAX6634/MAX6635 sink 4mA with the maximum $\overline{\text{ALERT}}$ V_L specification of 0.8V, an additional 3.2mW of power is dissipated within the IC. This corresponds to a 0.54°C rise in the die temperature.

Applications Information

Figure 10 shows the MAX6634 used as a simple thermostat to control a heating element. Figure 11 shows the MAX6635 used as a temperature-triggered fan controller.

Table 1. Address Selection

MAX6633				
A3	A2	A1	A0	ADDRESS
GND	GND	GND	GND	1000 000
GND	GND	GND	V _{CC}	1000 001
GND	GND	V _{CC}	GND	1000 010
GND	GND	V _{CC}	V _{CC}	1000 011
GND	V _{CC}	GND	GND	1000 100
GND	V _{CC}	GND	V _{CC}	1000 101
GND	V _{CC}	V _{CC}	GND	1000 110
GND	V _{CC}	V _{CC}	V _{CC}	1000 111
V _{CC}	GND	GND	GND	1001 000
V _{CC}	GND	GND	V _{CC}	1001 001
V _{CC}	GND	V _{CC}	GND	1001 010
V _{CC}	GND	V _{CC}	V _{CC}	1001 011
V _{CC}	V _{CC}	GND	GND	1001 100
V _{CC}	V _{CC}	GND	V _{CC}	1001 101
V _{CC}	V _{CC}	V _{CC}	GND	1001 110
V _{CC}	V _{CC}	V _{CC}	V _{CC}	1001 111
MAX6634				
	A2	A1	A0	ADDRESS
	GND	GND	GND	1001 000
	GND	GND	V _{CC}	1001 001
	GND	V _{CC}	GND	1001 010
	GND	V _{CC}	V _{CC}	1001 011
	V _{CC}	GND	GND	1001 100
	V _{CC}	GND	V _{CC}	1001 101
	V _{CC}	V _{CC}	GND	1001 110
	V _{CC}	V _{CC}	V _{CC}	1001 111
MAX6635				
		A1	A0	ADDRESS
		GND	GND	1001 000
		GND	V _{CC}	1001 001
		V _{CC}	GND	1001 010
		V _{CC}	V _{CC}	1001 011

Table 2. Pointer Register Bit Assignments

ADDRESS	DESCRIPTION	POR STATE
00h	Temperature register (READ only)	0000h
01h	Configuration-Byte register	00h
02h	T _{HYST} register	0100h
03h	T _{MAX} register	2800h
04h	T _{LOW} register	0500h
05h	T _{HIGH} register	2000h

Table 3. Temperature Register

D15	D14	D13	D12	D11	D10	D9	D8	D7	D6	D5	D4	D3	D2	D1	D0
MSB (Sign)	Bit 12	Bit 11	Bit 10	Bit 9	Bit 8	Bit 7	Bit 6	Bit 5	Bit 4	Bit 3	Bit 2	Bit 1	T _{MAX}	T _{HIGH}	T _{LOW}

D15: MSB is the first sign bit.

D2, D1, D0: Flag bits for T_{MAX}, T_{HIGH}, T_{LOW}.

1 LSB = 0.0625°C.

Temperature is stored in two's complement format.

Table 4. Configuration Register

D7	D6	D5	D4	D3	D2	D1	D0
0	0	SMB Timeout Disable	Fault Queue Enable	ALERT Polarity	OVERT Polarity	Comparator or Interrupt	Shutdown

Power-on default = 0h.

D0: 0 = normal operation; 1 = shutdown.

D1: 0 = comparator mode; 1 = interrupt mode.

D2 to D3: 0 = active low; 1 = active high.

D5: 0 = normal SMBus operation; 1 = full I²C compatibility.

D7 to D6: Reserved locations, always write zeros.

Table 5. Fault Queue Depth

D4	NO. OF FAULTS
0	1 (DEFAULT)
1	4

Table 6. Output Code vs. Temperature

TEMP. (°C)	DIGITAL OUTPUT CODE		
	BINARY		HEX
	MSB	LSB	
+150.0000	0100 1011 0000 0XXX		4B00
+125.0000	0011 1110 1000 0XXX		3E80
+25.0000	0000 1100 1000 0XXX		0C80
+0.0625	0000 0000 0000 1XXX		0008
0.0000	0000 0000 0000 0XXX		0000
-0.0625	1111 1111 1111 1XXX		FFF8
-25.0000	1111 0011 0111 0XXX		F370
-55.0000	1110 0100 0111 0XXX		E470

Table 7. T_{HIGH}, T_{LOW}, T_{MAX}, and T_{HYST} Registers

D15	D14	D13	D12	D11	D10	D9	D8	D7	D6	D5	D4	D3	D2	D1	D0
MSB (Sign)	Bit 7	Bit 6	Bit 5	Bit 4	Bit 3	Bit 2	Bit 1	LSB	0	0	0	0	0	0	0

D6 to D0: Reads all zeros, cannot be written.

1 LSB = 1°C.

Power-On Default: T_{HIGH} = +64°C (2000h), T_{LOW} = +10°C (0500h), T_{MAX} = +80°C (2008h), T_{HYST} = 2°C (0100h).

Pin Configurations

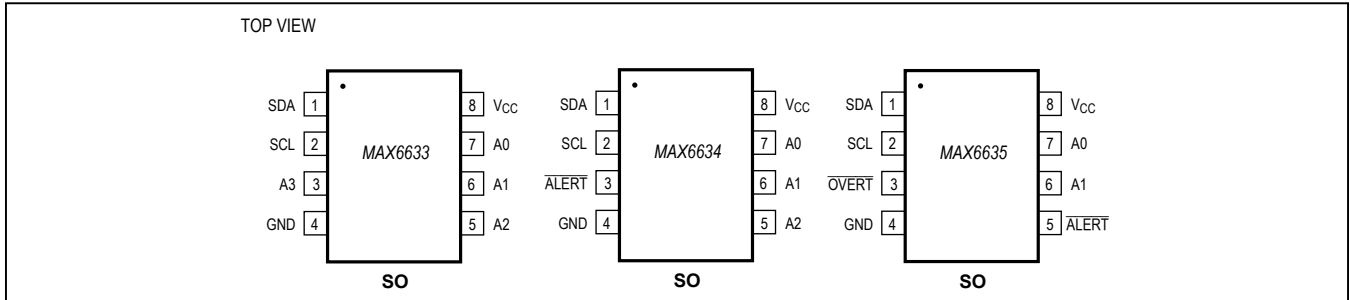

Chip Information

PROCESS: BICMOS

Package Information

For the latest package outline information and land patterns (footprints), go to www.maximintegrated.com/packages. Note that a "+", "#", or "-" in the package code indicates RoHS status only. Package drawings may show a different suffix character, but the drawing pertains to the package regardless of RoHS status.

PACKAGE TYPE	PACKAGE CODE	DOCUMENT NO.	LAND PATTERN NO.
8 SO	S8-2	21-0041	90-0096

Revision History

REVISION NUMBER	REVISION DATE	DESCRIPTION	PAGES CHANGED
0	8/01	Initial release	—
1	4/14	Removed automotive reference from <i>Applications</i>	1

For pricing, delivery, and ordering information, please contact Maxim Direct at 1-888-629-4642, or visit Maxim Integrated's website at www.maximintegrated.com.

Maxim Integrated cannot assume responsibility for use of any circuitry other than circuitry entirely embodied in a Maxim Integrated product. No circuit patent licenses are implied. Maxim Integrated reserves the right to change the circuitry and specifications without notice at any time. The parametric values (min and max limits) shown in the Electrical Characteristics table are guaranteed. Other parametric values quoted in this data sheet are provided for guidance.