

# Multi-Output, Low-Noise Power-Supply Controllers for Notebook Computers

## General Description

The MAX1630–MAX1635 are buck-topology, step-down, switch-mode, power-supply controllers that generate logic-supply voltages in battery-powered systems. These high-performance, dual/triple-output devices include on-board power-up sequencing, power-good signaling with delay, digital soft-start, secondary winding control, low-dropout circuitry, internal frequency-compensation networks, and automatic bootstrapping.

Up to 96% efficiency is achieved through synchronous rectification and Maxim's proprietary Idle Mode™ control scheme. Efficiency is greater than 80% over a 1000:1 load-current range, which extends battery life in system-suspend or standby mode. Excellent dynamic response corrects output load transients caused by the latest dynamic-clock CPUs within five 300kHz clock cycles. Strong 1A on-board gate drivers ensure fast external N-channel MOSFET switching.

These devices feature a logic-controlled and synchronizable, fixed-frequency, pulse-width-modulation (PWM) operating mode. This reduces noise and RF interference in sensitive mobile communications and pen-entry applications. Asserting the SKIP pin enables fixed-frequency mode, for lowest noise under all load conditions.

The MAX1630–MAX1635 include two PWM regulators, adjustable from 2.5V to 5.5V with fixed 5.0V and 3.3V modes. All these devices include secondary feedback regulation, and the MAX1630/MAX1632/MAX1633/MAX1635 each contain 12V/120mA linear regulators. The MAX1631/MAX1634 include a secondary feedback input (SECFB), plus a control pin (STEER) that selects which PWM (3.3V or 5V) receives the secondary feedback signal. SECFB provides a method for adjusting the secondary winding voltage regulation point with an external resistor divider, and is intended to aid in creating auxiliary voltages other than fixed 12V.

The MAX1630/MAX1631/MAX1632 contain internal output overvoltage and undervoltage protection features.

## Applications

Notebook and Subnotebook Computers  
PDAs and Mobile Communicators  
Desktop CPU Local DC-DC Converters

**Pin Configurations and Selector Guide appear at end of data sheet.**

*Idle Mode and Dual Mode are trademarks of Maxim Integrated Products.*

## Features

- ◆ 96% Efficiency
- ◆ +4.2V to +30V Input Range
- ◆ 2.5V to 5.5V Dual Adjustable Outputs
- ◆ Selectable 3.3V and 5V Fixed or Adjustable Outputs (Dual Mode™)
- ◆ 12V Linear Regulator
- ◆ Adjustable Secondary Feedback (MAX1631/MAX1634)
- ◆ 5V/50mA Linear Regulator Output
- ◆ Precision 2.5V Reference Output
- ◆ Programmable Power-Up Sequencing
- ◆ Power-Good (RESET) Output
- ◆ Output Overvoltage Protection (MAX1630/MAX1631/MAX1632)
- ◆ Output Undervoltage Shutdown (MAX1630/MAX1631/MAX1632)
- ◆ 200kHz/300kHz Low-Noise, Fixed-Frequency Operation
- ◆ Low-Dropout, 99% Duty-Factor Operation
- ◆ 2.5mW Typical Quiescent Power (+12V input, both SMPSs on)
- ◆ 4μA Typical Shutdown Current
- ◆ 28-Pin SSOP Package

## Ordering Information

PART	TEMP RANGE	PIN-PACKAGE
MAX1630CAI	0°C to +70°C	28 SSOP
MAX1630CAI+	0°C to +70°C	28 SSOP
MAX1630EAI+	-40°C to +85°C	28 SSOP

Ordering Information continued at end of data sheet.

+ Denotes lead-free package.

## Functional Diagram

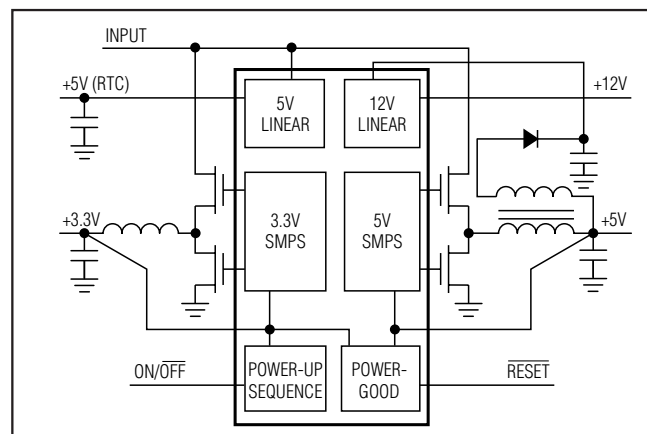

# Multi-Output, Low-Noise Power-Supply Controllers for Notebook Computers

## ABSOLUTE MAXIMUM RATINGS

V <sub>+</sub> to GND	-0.3V to +36V
PGND to GND	±0.3V
VL to GND	-0.3V to +6V
BST3, BST5 to GND	-0.3V to +36V
LX3 to BST3	-6V to +0.3V
LX5 to BST5	-6V to +0.3V
REF, SYNC, SEQ, STEER, SKIP, TIME/ON5, SECFB, RESET to GND	-0.3V to +6V
V <sub>DD</sub> to GND	-0.3V to +20V
RUN/ON3, SHDN to GND	-0.3V to (V <sub>+</sub> + 0.3V)
12OUT to GND	-0.3V to (V <sub>DD</sub> + 0.3V)
DL3, DL5 to PGND	-0.3V to (VL + 0.3V)
DH3 to LX3	-0.3V to (BST3 + 0.3V)
DH5 to LX5	-0.3V to (BST5 + 0.3V)

VL, REF Short to GND	Momentary
12OUT Short to GND	Continuous
REF Current	+5mA to -1mA
VL Current	+50mA
12OUT Current	+200mA
V <sub>DD</sub> Shunt Current	+15mA
Operating Temperature Ranges	
MAX163_CAI	0°C to +70°C
MAX163_EAI	-40°C to +85°C
Storage Temperature Range	-65°C to +160°C
Continuous Power Dissipation (T <sub>A</sub> = +70°C)	
SSOP (derate 9.52mW/°C above +70°C)	762mW
Lead Temperature (soldering, 10s)	+300°C

Stresses beyond those listed under "Absolute Maximum Ratings" may cause permanent damage to the device. These are stress ratings only, and functional operation of the device at these or any other conditions beyond those indicated in the operational sections of the specifications is not implied. Exposure to absolute maximum rating conditions for extended periods may affect device reliability.

## ELECTRICAL CHARACTERISTICS

(V<sub>+</sub> = 15V, both PWMs on, SYNC = VL, VL load = 0mA, REF load = 0mA,  $\overline{\text{SKIP}}$  = 0V, T<sub>A</sub> = T<sub>MIN</sub> to T<sub>MAX</sub>, unless otherwise noted. Typical values are at T<sub>A</sub> = +25°C.)

PARAMETER	CONDITIONS	MIN	TYP	MAX	UNITS
<b>MAIN SMPS CONTROLLERS</b>					
Input Voltage Range		4.2		30.0	V
3V Output Voltage in Adjustable Mode	V <sub>+</sub> = 4.2V to 30V, CSH3- $\overline{\text{CSL3}}$ = 0V, $\overline{\text{CSL3}}$ tied to FB3	2.42	2.5	2.58	V
3V Output Voltage in Fixed Mode	V <sub>+</sub> = 4.2V to 30V, 0mV < CSH3- $\overline{\text{CSL3}}$ < 80mV, FB3 = 0V	3.20	3.39	3.47	V
5V Output Voltage in Adjustable Mode	V <sub>+</sub> = 4.2V to 30V, CSH5- $\overline{\text{CSL5}}$ = 0V, $\overline{\text{CSL5}}$ tied to FB5	2.42	2.5	2.58	V
5V Output Voltage in Fixed Mode	V <sub>+</sub> = 5.2V to 30V, 0mV < CSH- $\overline{\text{CSL5}}$ < 80mV, FB5 = 0V	4.85	5.13	5.25	V
Output Voltage Adjust Range	Either SMPS	REF		5.5	V
Adjustable-Mode Threshold Voltage	Dual Mode comparator	0.5		1.1	V
Load Regulation	Either SMPS, 0V < CSH_ $\overline{\text{CSL}}$ < 80mV		-2		%
Line Regulation	Either SMPS, 5.2V < V <sub>+</sub> < 30V		0.03		%/V
Current-Limit Threshold	CSH3- $\overline{\text{CSL3}}$ or CSH5- $\overline{\text{CSL5}}$	80	100	120	mV
	$\overline{\text{SKIP}}$ = VL or V <sub>DD</sub> < 13V or SECFB < 2.44V	-50	-100	-150	
Idle Mode Threshold	$\overline{\text{SKIP}}$ = 0V, not tested	10	25	40	mV
Soft-Start Ramp Time	From enable to 95% full current limit with respect to f <sub>OSC</sub> (Note 1)		512		Clk
Oscillator Frequency	SYNC = VL	270	300	330	kHz
	SYNC = 0V	170	200	230	
Maximum Duty Factor	SYNC = VL	97	98		%
	SYNC = 0V (Note 2)	98	99		

# Multi-Output, Low-Noise Power-Supply Controllers for Notebook Computers

MAX1630-MAX1635

## ELECTRICAL CHARACTERISTICS (continued)

(V+ = 15V, both PWMs on, SYNC = VL, VL load = 0mA, REF load = 0mA,  $\overline{\text{SKIP}}$  = 0V, T<sub>A</sub> = T<sub>MIN</sub> to T<sub>MAX</sub>, unless otherwise noted. Typical values are at T<sub>A</sub> = +25°C.)

PARAMETER	CONDITIONS	MIN	TYP	MAX	UNITS
SYNC Input High Pulse Width	Not tested	200			ns
SYNC Input Low Pulse Width	Not tested	200			ns
SYNC Rise/Fall Time	Not tested			200	ns
SYNC Input Frequency Range		240		350	kHz
Current-Sense Input Leakage Current	V+ = VL = 0V, CSL3 = CSH3 = CSL5 = CSH5 = 5.5V		0.01	10	μA
<b>FLYBACK CONTROLLER</b>					
V <sub>DD</sub> Regulation Threshold	Falling edge (Note 3)	13		14	V
SECFB Regulation Threshold	Falling edge (MAX1631/MAX1634)	2.44		2.60	V
DL Pulse Width	V <sub>DD</sub> < 13V or SECFB < 2.44V		1		μs
V <sub>DD</sub> Shunt Threshold	Rising edge, hysteresis = 1% (Note 3)	18		20	V
V <sub>DD</sub> Shunt Sink Current	V <sub>DD</sub> = 20V (Note 3)	10			mA
V <sub>DD</sub> Leakage Current	V <sub>DD</sub> = 5V, off mode (Notes 3, 4)			30	μA
<b>12V LINEAR REGULATOR (Note 3)</b>					
12OUT Output Voltage	13V < V <sub>DD</sub> < 18V, 0mA < I <sub>LOAD</sub> < 120mA	11.65	12.1	12.50	V
12OUT Current Limit	12OUT forced to 11V, V <sub>DD</sub> = 13V		150		mA
Quiescent V <sub>DD</sub> Current	V <sub>DD</sub> = 18V, run mode, no 12OUT load		50	100	μA
<b>INTERNAL REGULATOR AND REFERENCE</b>					
VL Output Voltage	$\overline{\text{SHDN}}$ = V+, RUN/ON3 = TIME/ON5 = 0V, 5.3V < V+ < 30V, 0mA < I <sub>LOAD</sub> < 50mA	4.7		5.1	V
VL Undervoltage Lockout Fault Threshold	Falling edge, hysteresis = 1%	3.5	3.6	3.7	V
VL Switchover Threshold	Rising edge of CSL5, hysteresis = 1%	4.2	4.5	4.7	V
REF Output Voltage	No external load (Note 5)	2.45	2.5	2.55	V
REF Load Regulation	0μA < I <sub>LOAD</sub> < 50μA			12.5	mV
	0mA < I <sub>LOAD</sub> < 5mA			100.0	
REF Sink Current		10			μA
REF Fault Lockout Voltage	Falling edge	1.8		2.4	V
V+ Operating Supply Current	VL switched over to CSL5, 5V SMPS on		5	50	μA
V+ Standby Supply Current	V+ = 5.5V to 30V, both SMPSs off, includes current into $\overline{\text{SHDN}}$		30	60	μA
V+ Standby Supply Current in Dropout	V+ = 4.2V to 5.5V, both SMPSs off, includes current into $\overline{\text{SHDN}}$		50	200	μA
V+ Shutdown Supply Current	V+ = 4V to 24V, $\overline{\text{SHDN}}$ = 0V		4	10	μA
Quiescent Power Consumption	Both SMPSs enabled, FB3 = FB5 = 0V, CSL3 = CSH3 = 3.5V, CSL5 = CSH5 = 5.3V	(Note 3)	2.5	4	mW
		MAX1631/ MAX1634	1.5	4	

# Multi-Output, Low-Noise Power-Supply Controllers for Notebook Computers

## ELECTRICAL CHARACTERISTICS (continued)

(V+ = 15V, both PWMs on, SYNC = VL, VL load = 0mA, REF load = 0mA,  $\overline{\text{SKIP}}$  = 0V, T<sub>A</sub> = T<sub>MIN</sub> to T<sub>MAX</sub>, unless otherwise noted. Typical values are at T<sub>A</sub> = +25°C.)

PARAMETER	CONDITIONS	MIN	TYP	MAX	UNITS
<b>FAULT DETECTION (MAX1630/MAX1631/MAX1632)</b>					
Overvoltage Trip Threshold	With respect to unloaded output voltage	4	7	10	%
Overvoltage-Fault Propagation Delay	CSL_ driven 2% above overvoltage trip threshold		1.5		μs
Output Undervoltage Threshold	With respect to unloaded output voltage	60	70	80	%
Output Undervoltage Lockout Time	From each SMPS enabled, with respect to fosc	5000	6144	7000	Clk
Thermal Shutdown Threshold	Typical hysteresis = +10°C		150		°C
<b>RESET</b>					
$\overline{\text{RESET}}$ Trip Threshold	With respect to unloaded output voltage, falling edge; typical hysteresis = 1%	-7	-5.5	-4	%
$\overline{\text{RESET}}$ Propagation Delay	Falling edge, CSL_ driven 2% below $\overline{\text{RESET}}$ trip threshold		1.5		μs
$\overline{\text{RESET}}$ Delay Time	With respect to fosc	27,000	32,000	37,000	Clk
<b>INPUTS AND OUTPUTS</b>					
Feedback Input Leakage Current	FB3, FB5; SECFB = 2.6V		1	50	nA
Logic Input Low Voltage	RUN/ON3, $\overline{\text{SKIP}}$ , TIME/ON5 (SEQ = REF), $\overline{\text{SHDN}}$ , STEER, SYNC			0.6	V
Logic Input High Voltage	RUN/ON3, $\overline{\text{SKIP}}$ , TIME/ON5 (SEQ = REF), $\overline{\text{SHDN}}$ , STEER, SYNC	2.4			V
Input Leakage Current	RUN/ON3, $\overline{\text{SKIP}}$ , TIME/ON5 (SEQ = REF), $\overline{\text{SHDN}}$ , STEER, SYNC, SEQ; V <sub>PIIN</sub> = 0V or 3.3V			±1	μA
Logic Output Low Voltage	$\overline{\text{RESET}}$ , I <sub>SINK</sub> = 4mA			0.4	V
Logic Output High Current	$\overline{\text{RESET}}$ = 3.5V	1			mA
TIME/ON5 Input Trip Level	SEQ = 0V or VL	2.4		2.6	V
TIME/ON5 Source Current	TIME/ON5 = 0V, SEQ = 0V or VL	2.5	3	3.5	μA
TIME/ON5 On-Resistance	TIME/ON5; RUN/ON3 = 0V, SEQ = 0V or VL		15	80	Ω
Gate Driver Sink/Source Current	DL3, DH3, DL5, DH5; forced to 2V		1		A
Gate Driver On-Resistance	High or low		1.5	7	Ω

**Note 1:** Each of the four digital soft-start levels is tested for functionality; the steps are typically in 20mV increments.

**Note 2:** High duty-factor operation supports low input-to-output differential voltages, and is achieved at a lowered operating frequency (see *Overload and Dropout Operation* section).

**Note 3:** MAX1630/MAX1632/MAX1633/MAX1635 only.

**Note 4:** Off mode for the 12V linear regulator occurs when the SMPS that has flyback feedback (V<sub>DD</sub>) steered to it is disabled. In situations where the main outputs are being held up by external keep-alive supplies, turning off the 12OUT regulator prevents a leakage path from the output-referred flyback winding, through the rectifier, and into V<sub>DD</sub>.

**Note 5:** Since the reference uses VL as its supply, the reference's V+ line-regulation error is insignificant.

# Multi-Output, Low-Noise Power-Supply Controllers for Notebook Computers

## Typical Operating Characteristics

(Circuit of Figure 1, 3A Table 1 components,  $T_A = +25^\circ\text{C}$ , unless otherwise noted.)

MAX1630-MAX1635

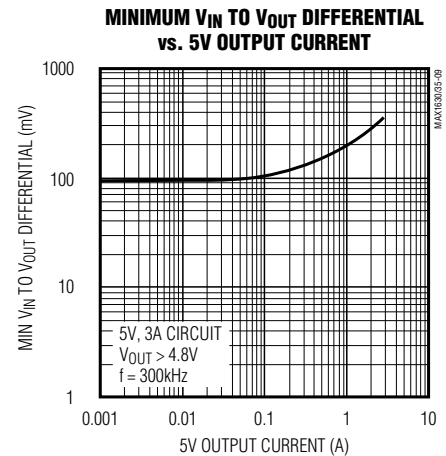
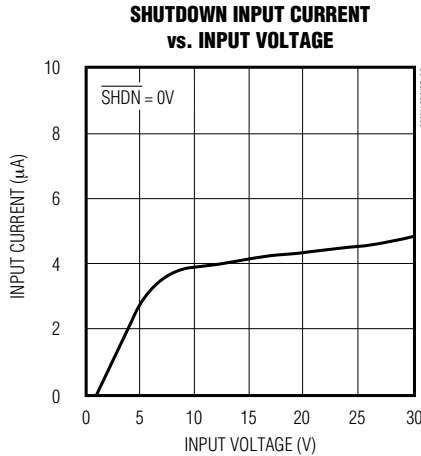
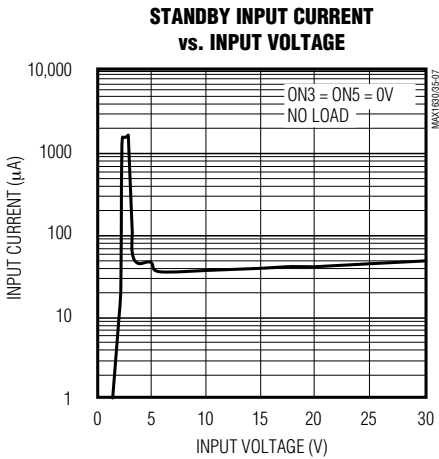
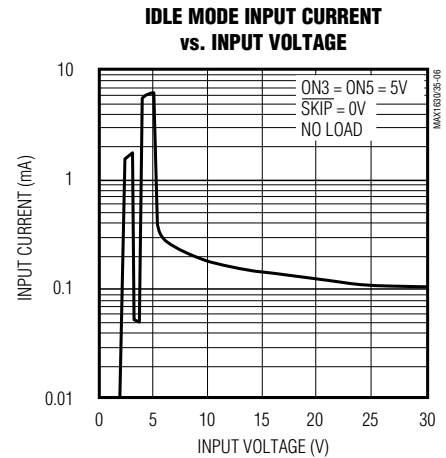
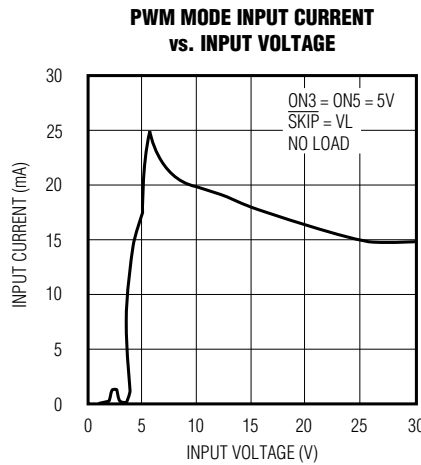
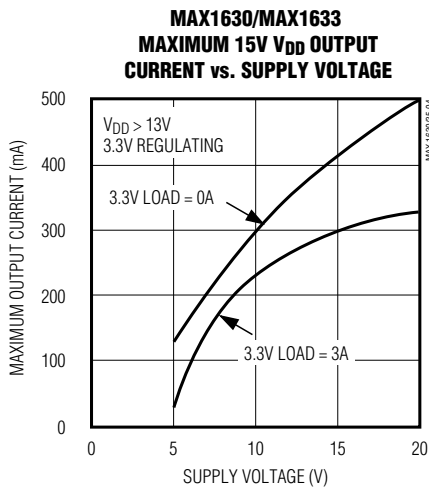
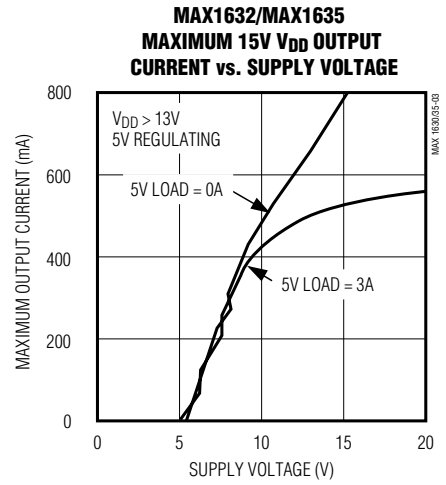
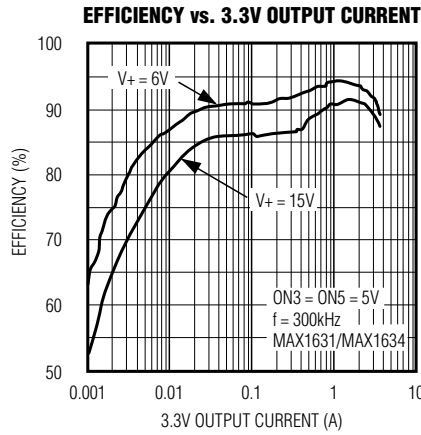
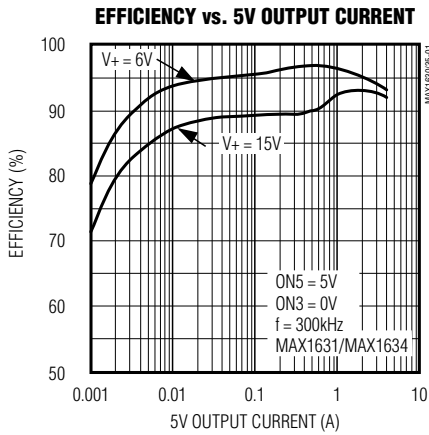

# Multi-Output, Low-Noise Power-Supply Controllers for Notebook Computers

## Typical Operating Characteristics (continued)

(Circuit of Figure 1, 3A Table 1 components,  $T_A = +25^\circ\text{C}$ , unless otherwise noted.)

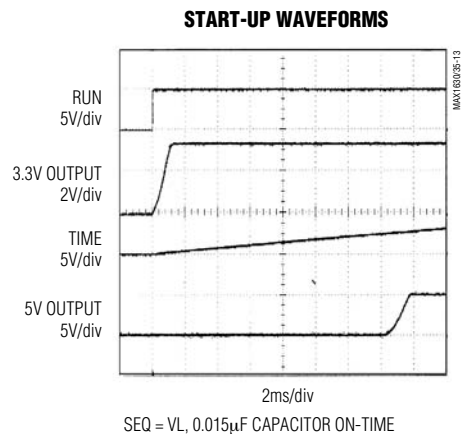
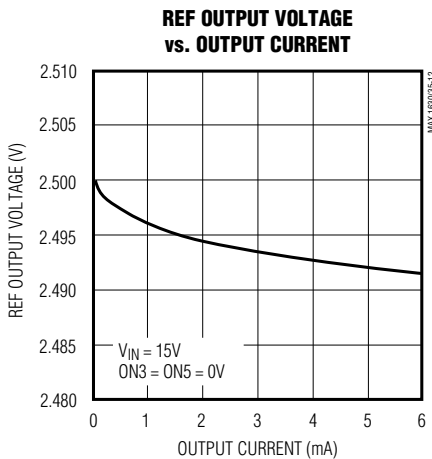
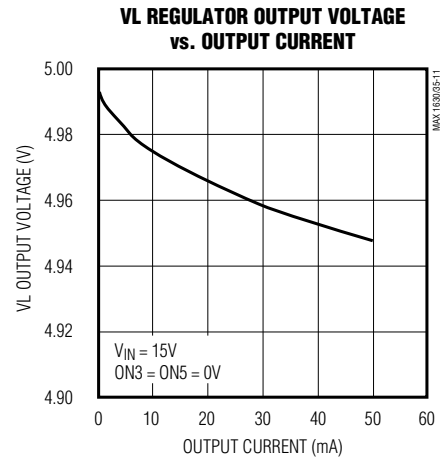
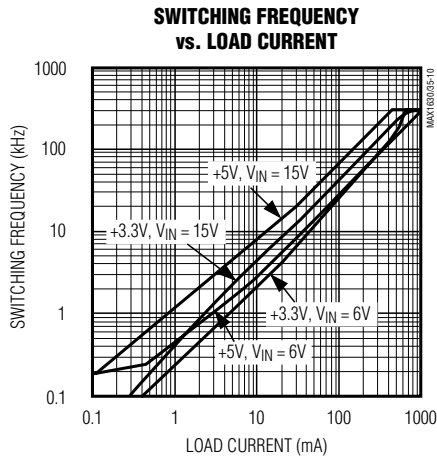

## Pin Description

PIN	NAME	FUNCTION
1	CSH3	Current-Sense Input for the 3.3V SMPS. Current-limit level is 100mV referred to CSL3.
2	CSL3	Current-Sense Input. Also serves as the feedback input in fixed-output mode.
3	FB3	Feedback Input for the 3.3V SMPS; regulates at $FB3 = REF$ (approx. 2.5V) in adjustable mode. FB3 is a Dual Mode input that also selects the 3.3V fixed output voltage setting when tied to GND. Connect FB3 to a resistor divider for adjustable-output mode.
4	12OUT (MAX1630/ 32/33/35)	12V/120mA Linear Regulator Output. Input supply comes from $V_{DD}$ . Bypass 12OUT to GND with $1\mu\text{F}$ minimum.
	STEER (MAX1631/ MAX1634)	Logic-Control Input for secondary feedback. Selects the PWM that uses a transformer and secondary feedback signal (SECFB): STEER = GND: 3.3V SMPS uses transformer STEER = VL: 5V SMPS uses transformer

# Multi-Output, Low-Noise Power-Supply Controllers for Notebook Computers

## Pin Description (continued)

MAX1630-MAX1635

PIN	NAME	FUNCTION
5	V <sub>DD</sub> (MAX1630/ 32/33/35)	Supply Voltage Input for the 12OUT Linear Regulator. Also connects to an internal resistor divider for secondary winding feedback, and to an 18V overvoltage shunt regulator clamp.
	SECFB (MAX1631/ MAX1634)	Secondary Winding Feedback Input. Normally connected to a resistor divider from an auxiliary output. SECFB regulates at V <sub>SECFB</sub> = 2.5V (see <i>Secondary Feedback Regulation Loop</i> section). Tie to VL if not used.
6	SYNC	Oscillator Synchronization and Frequency Select. Tie to VL for 300kHz operation; tie to GND for 200kHz operation. Can be driven at 240kHz to 350kHz for external synchronization.
7	TIME/ON5	Dual-Purpose Timing Capacitor Pin and ON/OFF Control Input. See <i>Power-Up Sequencing and ON/OFF Controls</i> section.
8	GND	Low-Noise Analog Ground and Feedback Reference Point
9	REF	2.5V Reference Voltage Output. Bypass to GND with 1μF minimum.
10	SKIP	Logic-Control Input that disables Idle Mode when high. Connect to GND for normal use.
11	RESET	Active-Low Timed Reset Output. RESET swings GND to VL. Goes high after a fixed 32,000 clock-cycle delay following power-up.
12	FB5	Feedback Input for the 5V SMPS; regulates at FB5 = REF (approx. 2.5V) in adjustable mode. FB5 is a Dual Mode input that also selects the 5V fixed output voltage setting when tied to GND. Connect FB5 to a resistor divider for adjustable-output mode.
13	CSL5	Current-Sense Input for the 5V SMPS. Also serves as the feedback input in fixed-output mode, and as the bootstrap supply input when the voltage on CSL5/VL is > 4.5V.
14	CSH5	Current-Sense Input for the 5V SMPS. Current-limit level is 100mV referred to CSL5.
15	SEQ	Pin-Strap Input that selects the SMPS power-up sequence: SEQ = GND: 5V before 3.3V, RESET output determined by both outputs SEQ = REF: Separate ON3/ON5 controls, RESET output determined by 3.3V output SEQ = VL: 3.3V before 5V, RESET output determined by both outputs
16	DH5	Gate-Drive Output for the 5V, high-side N-channel switch. DH5 is a floating driver output that swings from LX5 to BST5, riding on the LX5 switching node voltage.
17	LX5	Switching Node (inductor) Connection. Can swing 2V below ground without hazard.
18	BST5	Boost capacitor connection for high-side gate drive (0.1μF)
19	DL5	Gate-Drive Output for the low-side synchronous-rectifier MOSFET. Swings 0V to VL.
20	PGND	Power Ground
21	VL	5V Internal Linear-Regulator Output. VL is also the supply voltage rail for the chip. After the 5V SMPS output has reached +4.5V (typical), VL automatically switches to the output voltage via CSL5 for bootstrapping. Bypass to GND with 4.7μF. VL supplies up to 25mA for external loads.
22	V+	Battery Voltage Input, +4.2V to +30V. Bypass V+ to PGND close to the IC with a 0.22μF capacitor. Connects to a linear regulator that powers VL.
23	SHDN	Shutdown Control Input, active low. Logic threshold is set at approximately 1V. For automatic start-up, connect SHDN to V+ through a 220kΩ resistor and bypass SHDN to GND with a 0.01μF capacitor.
24	DL3	Gate-Drive Output for the low-side synchronous-rectifier MOSFET. Swings 0V to VL.
25	BST3	Boost Capacitor Connection for high-side gate drive (0.1μF)
26	LX3	Switching Node (inductor) Connection. Can swing 2V below ground without hazard.
27	DH3	Gate-Drive Output for the 3.3V, high-side N-channel switch. DH3 is a floating driver output that swings from LX3 to BST3, riding on the LX3 switching node voltage.
28	RUN/ON3	ON/OFF Control Input. See <i>Power-Up Sequencing and ON/OFF Controls</i> section.

# Multi-Output, Low-Noise Power-Supply Controllers for Notebook Computers

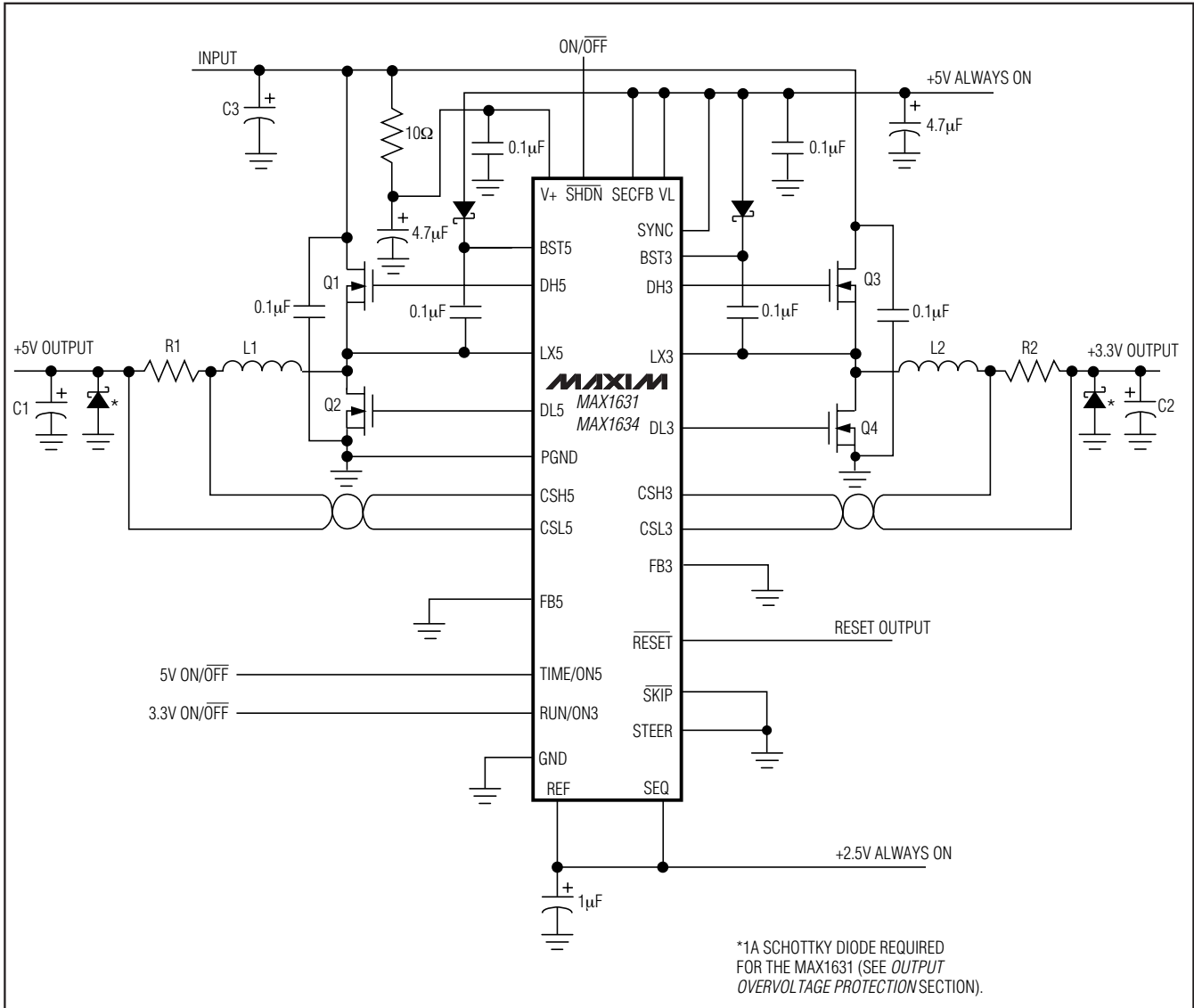

Figure 1. Standard 3.3V/5V Application Circuit (MAX1631/MAX1634)

## Standard Application Circuit

The basic MAX1631/MAX1634 dual-output 3.3V/5V buck converter (Figure 1) is easily adapted to meet a wide range of applications with inputs up to 28V by substituting components from Table 1. These circuits represent a good set of tradeoffs between cost, size, and efficiency, while staying within the worst-case specification limits for stress-related parameters, such as capacitor ripple current. Don't change the frequency

of these circuits without first recalculating component values (particularly inductance value at maximum battery voltage). Adding a Schottky rectifier across each synchronous rectifier improves the efficiency of these circuits by approximately 1%, but this rectifier is otherwise not needed because the MOSFETs required for these circuits typically incorporate a high-speed silicon diode from drain to source. Use a Schottky rectifier rated at a DC current equal to at least one-third of the load current.



# Multi-Output, Low-Noise Power-Supply Controllers for Notebook Computers

**MAX1630-MAX1635**

**Table 1. Component Selection for Standard 3.3V/5V Application**

COMPONENT	LOAD CURRENT		
	2A	3A	4A
Input Range	4.75V to 18V	4.75V to 28V	4.75V to 24V
Application	PDA	Notebook	Workstation
Frequency	300kHz	300kHz	200kHz
Q1, Q3 High-Side MOSFETs	1/2 IR IRF7301; 1/2 Siliconix Si9925DQ; or 1/2 Motorola MMDF3N03HD or MMDF4N01HD (10V max)	IR IRF7403 or IRF7401 (18V max); Siliconix Si4412DY; or Motorola MMSF5N03HD or MMSF5N02HD (18V max)	IR IRF7413 or Siliconix Si4410DY
Q2, Q4 Low-Side MOSFETs	1/2 IR IRF7301; 1/2 Siliconix Si9925DQ; or 1/2 Motorola MMDF3N03HD or MMDF4N01HD (10V max)	IR IRF7403 or IRF7401 (18V max); Siliconix Si4412DY; or Motorola MMSF5N03HD or MMSF5N02HD (18V max)	IR IRF7413 or Siliconix Si4410DY
C3 Input Capacitor	10µF, 30V Sanyo OS-CON; 22µF, 35V AVX TPS; or Sprague 594D	2 x 10µF, 30V Sanyo OS-CON; 2 x 22µF, 35V AVX TPS; or Sprague 594D	3 x 10µF, 30V Sanyo OS-CON; 4 x 22µF, 35V AVX TPS; or Sprague 595D
C1, C2 Output Capacitors	220µF, 10V AVX TPS or Sprague 595D	2 x 220µF, 10V AVX TPS or Sprague 595D	4 x 220µF, 10V AVX TPS or Sprague 595D
R1, R2 Resistors	0.033Ω IRC LR2010-01-R033 or Dale WSL2010-R033-F	0.02Ω IRC LR2010-01-R020 or Dale WSL2010-R020-F	0.012Ω Dale WSL2512-R012-F
L1, L2 Inductors	15µH, 2.4A Ferrite Coilcraft DO3316P-153 or Sumida CDRH125-150	10µH, 4A Ferrite Coilcraft DO3316P-103 or Sumida CDRH125-100	4.7µH, 5.5A Ferrite Coilcraft DO3316-472 or 5.2µH, 6.5A Ferrite Sumida CDRH127-5R2MC

**Table 2. Component Suppliers**

COMPANY	FACTORY FAX (COUNTRY CODE)	USA PHONE
AVX	(1) 803-626-3123	(803) 946-0690
Central Semiconductor	(1) 516-435-1824	(516) 435-1110
Coilcraft	(1) 847-639-1469	(847) 639-6400
Coiltronics	(1) 561-241-9339	(561) 241-7876
Dale	(1) 605-665-1627	(605) 668-4131
International Rectifier (IR)	(1) 310-322-3332	(310) 322-3331
IRC	(1) 512-992-3377	(512) 992-7900
Matsuo	(1) 714-960-6492	(714) 969-2491

COMPANY	FACTORY FAX (COUNTRY CODE)	USA PHONE
Motorola	(1) 602-994-6430	(602) 303-5454
Murata-Erie	(1) 814-238-0490	(814) 237-1431
NIEC	(81) 3-3494-7414	(805) 867-2555*
Sanyo	(81) 7-2070-1174	(619) 661-6835
Siliconix	(1) 408-970-3950	(408) 988-8000
Sprague	(1) 603-224-1430	(603) 224-1961
Sumida	(81) 3-3607-5144	(847) 956-0666
TDK	(1) 847-390-4428	(847) 390-4373
Transpower Technologies	(1) 702-831-3521	(702) 831-0140

\*Distributor

# Multi-Output, Low-Noise Power-Supply Controllers for Notebook Computers

MAX1630-MAX1635

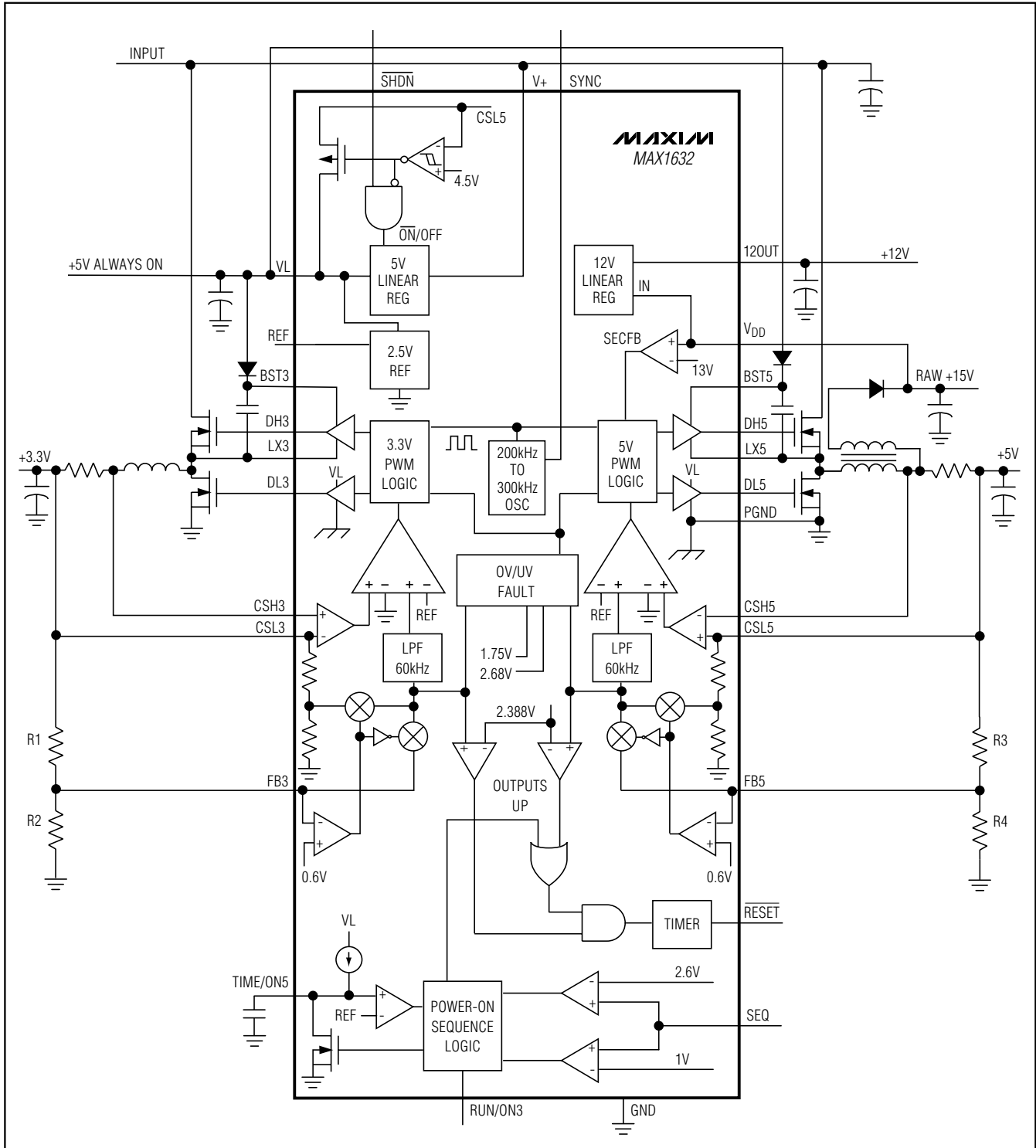

Figure 2. MAX1632 Block Diagram

# Multi-Output, Low-Noise Power-Supply Controllers for Notebook Computers

## Detailed Description

The MAX1630 is a dual, BiCMOS, switch-mode power-supply controller designed primarily for buck-topology regulators in battery-powered applications where high efficiency and low quiescent supply current are critical. Light-load efficiency is enhanced by automatic Idle Mode™ operation, a variable-frequency pulse-skipping mode that reduces transition and gate-charge losses. Each step-down, power-switching circuit consists of two N-channel MOSFETs, a rectifier, and an LC output filter. The output voltage is the average AC voltage at the switching node, which is regulated by changing the duty cycle of the MOSFET switches. The gate-drive signal to the N-channel high-side MOSFET must exceed the battery voltage, and is provided by a flying-capacitor boost circuit that uses a 100nF capacitor connected to BST\_.

Devices in the MAX1630 family contain ten major circuit blocks (Figure 2).

The two pulse-width modulation (PWM) controllers each consist of a Dual Mode™ feedback network and multiplexer, a multi-input PWM comparator, high-side and low-side gate drivers, and logic. MAX1630/MAX1631/MAX1632 contain fault-protection circuits that monitor the main PWM outputs for undervoltage and overvoltage. A power-on sequence block controls the power-up timing of the main PWMs and determines whether one or both of the outputs are monitored for undervoltage faults. The MAX1630/MAX1632/MAX1633/MAX1635 include a secondary feedback network and 12V linear regulator to generate a 12V output from a coupled-inductor flyback winding. The MAX1631/MAX1634 have a secondary feedback input (SECFB) instead, which allows a quasi-regulated, adjustable-output, coupled-inductor flyback winding to be attached to either the 3.3V or the 5V main inductor. Bias generator blocks include the 5V IC internal rail (VL) linear regulator, 2.5V precision reference, and automatic bootstrap switchover circuit. The PWMs share a common 200kHz/300kHz synchronizable oscillator.

These internal IC blocks aren't powered directly from the battery. Instead, the 5V VL linear regulator steps down the battery voltage to supply both VL and the gate drivers. The synchronous-switch gate drivers are directly powered from VL, while the high-side switch gate drivers are indirectly powered from VL via an external diode-capacitor boost circuit. An automatic bootstrap circuit turns off the +5V linear regulator and powers the IC from the 5V PWM output voltage if the output is above 4.5V.

## PWM Controller Block

The two PWM controllers are nearly identical. The only differences are fixed output settings (3.3V vs. 5V), the VL/CSL5 bootstrap switch connected to the +5V PWM, and SECFB. The heart of each current-mode PWM controller is a multi-input, open-loop comparator that sums three signals: the output voltage error signal with respect to the reference voltage, the current-sense signal, and the slope compensation ramp (Figure 3). The PWM controller is a direct-summing type, lacking a traditional error amplifier and the phase shift associated with it. This direct-summing configuration approaches ideal cycle-by-cycle control over the output voltage.

When  $\overline{\text{SKIP}} = \text{low}$ , Idle Mode circuitry automatically optimizes efficiency throughout the load current range. Idle Mode dramatically improves light-load efficiency by reducing the effective frequency, which reduces switching losses. It keeps the peak inductor current above 25% of the full current limit in an active cycle, allowing subsequent cycles to be skipped. Idle Mode transitions seamlessly to fixed-frequency PWM operation as load current increases.

With  $\overline{\text{SKIP}} = \text{high}$ , the controller always operates in fixed-frequency PWM mode for lowest noise. Each pulse from the oscillator sets the main PWM latch that turns on the high-side switch for a period determined by the duty factor (approximately  $V_{\text{OUT}}/V_{\text{IN}}$ ). As the high-side switch turns off, the synchronous rectifier latch sets; 60ns later, the low-side switch turns on. The low-side switch stays on until the beginning of the next clock cycle.

**Table 3.  $\overline{\text{SKIP}}$  PWM Table**

$\overline{\text{SKIP}}$	LOAD CURRENT	MODE	DESCRIPTION
Low	Light	Idle	Pulse-skipping, supply current = 250µA at $V_{\text{IN}} = 12\text{V}$ , discontinuous inductor current
Low	Heavy	PWM	Constant-frequency PWM, continuous inductor current
High	Light	PWM	Constant-frequency PWM, continuous inductor current
High	Heavy	PWM	Constant-frequency PWM, continuous inductor current

# Multi-Output, Low-Noise Power-Supply Controllers for Notebook Computers

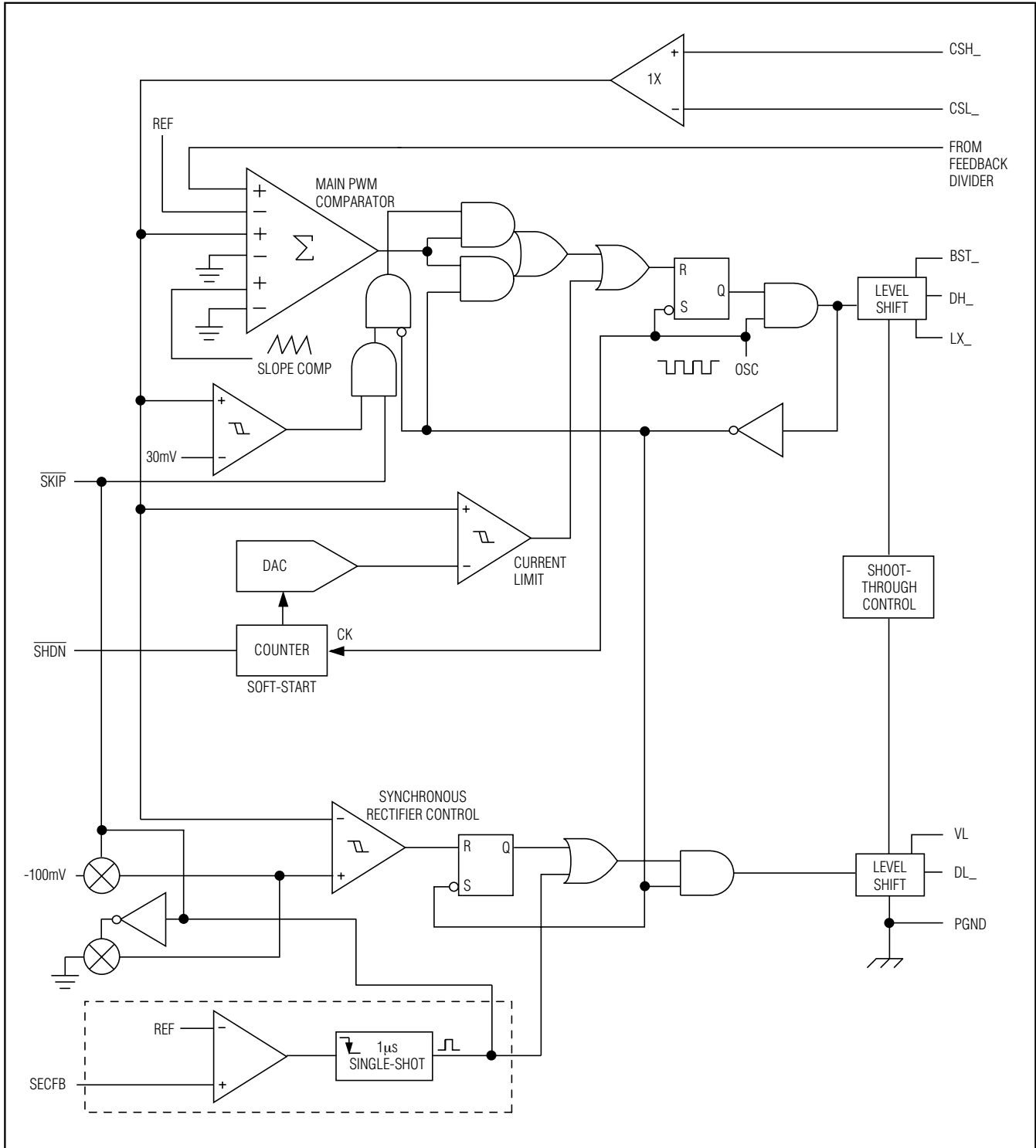

Figure 3. PWM Controller Detailed Block Diagram

## Multi-Output, Low-Noise Power-Supply Controllers for Notebook Computers

In PWM mode, the controller operates as a fixed-frequency current-mode controller where the duty ratio is set by the input/output voltage ratio. The current-mode feedback system regulates the peak inductor current value as a function of the output-voltage error signal. In continuous-conduction mode, the average inductor current is nearly the same as the peak current, so the circuit acts as a switch-mode transconductance amplifier. This pushes the second output LC filter pole, normally found in a duty-factor-controlled (voltage-mode) PWM, to a higher frequency. To preserve inner-loop stability and eliminate regenerative inductor current “staircasing,” a slope compensation ramp is summed into the main PWM comparator to make the apparent duty factor less than 50%.

The MAX1630 family uses a relatively low loop gain, allowing the use of lower-cost output capacitors. The relative gains of the voltage-sense and current-sense inputs are weighted by the values of current sources that bias three differential input stages in the main PWM comparator (Figure 4). The relative gain of the voltage comparator to the current comparator is internally fixed at  $K = 2:1$ . The low loop gain results in the 2% typical load-regulation error. The low value of loop gain helps reduce output filter capacitor size and cost by shifting the unity-gain crossover frequency to a lower level.

The output filter capacitors (Figure 1, C1 and C2) set a dominant pole in the feedback loop that must roll off the loop gain to unity before encountering the zero introduced by the output capacitor’s parasitic resistance (ESR) (see *Design Procedure* section). A 60kHz pole-zero cancellation filter provides additional rolloff above the unity-gain crossover. This internal 60kHz lowpass compensation filter cancels the zero due to filter capacitor ESR. The 60kHz filter is included in the loop in both fixed-output and adjustable-output modes.

### Synchronous Rectifier Driver (DL)

Synchronous rectification reduces conduction losses in the rectifier by shunting the normal Schottky catch diode with a low-resistance MOSFET switch. Also, the synchronous rectifier ensures proper start-up of the boost gate-driver circuit. If the synchronous power MOSFETs are omitted for cost or other reasons, replace them with a small-signal MOSFET, such as a 2N7002.

If the circuit is operating in continuous-conduction mode, the DL drive waveform is simply the complement of the DH high-side drive waveform (with controlled dead time to prevent cross-conduction or “shoot-through”). In discontinuous (light-load) mode, the synchronous switch is turned off as the inductor current falls through zero. The synchronous rectifier works

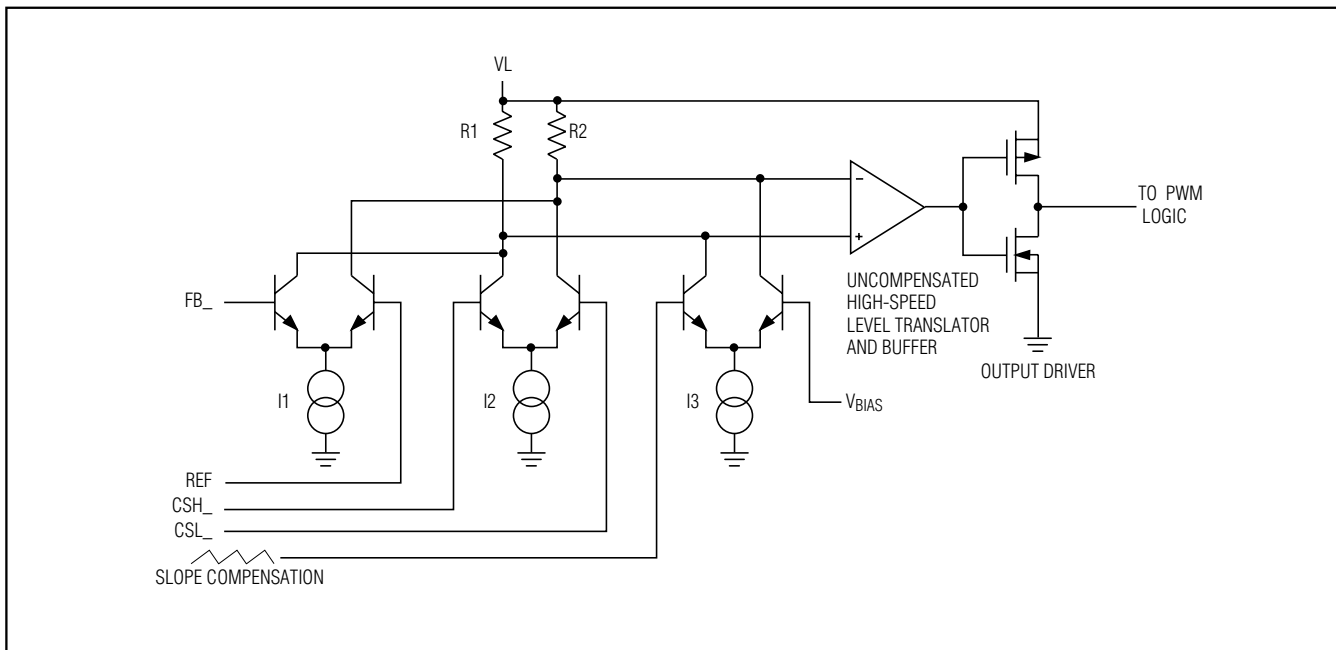

Figure 4. Main PWM Comparator Block Diagram

# Multi-Output, Low-Noise Power-Supply Controllers for Notebook Computers

under all operating conditions, including Idle Mode. The SECFB signal further controls the synchronous switch timing in order to improve multiple-output cross-regulation (see *Secondary Feedback Regulation Loop* section).

## Internal VL and REF Supplies

An internal regulator produces the +5V supply (VL) that powers the PWM controller, logic, reference, and other blocks within the IC. This 5V low-dropout linear regulator supplies up to 25mA for external loads, with a reserve of 25mA for supplying gate-drive power. Bypass VL to GND with 4.7 $\mu$ F.

**Important:** Ensure that VL does not exceed 6V. Measure VL with the main output fully loaded. If it is pumped above 5.5V, either excessive boost diode capacitance or excessive ripple at V+ is the probable cause. Use only small-signal diodes for the boost circuit (10mA to 100mA Schottky or 1N4148 are preferred), and bypass V+ to PGND with 4.7 $\mu$ F directly at the package pins.

The 2.5V reference (REF) is accurate to  $\pm 2\%$  over temperature, making REF useful as a precision system reference. Bypass REF to GND with 1 $\mu$ F minimum. REF can supply up to 5mA for external loads. (Bypass REF with a minimum 1 $\mu$ F/mA reference load current.) However, if extremely accurate specifications for both the main output voltages and REF are essential, avoid loading REF more than 100 $\mu$ A. Loading REF reduces the main output voltage slightly, because of the reference load-regulation error.

When the 5V main output voltage is above 4.5V, an internal P-channel MOSFET switch connects CSL5 to VL, while simultaneously shutting down the VL linear regulator. This action bootstraps the IC, powering the internal circuitry from the output voltage, rather than through a linear regulator from the battery. Bootstrapping reduces power dissipation due to gate charge and quiescent losses by providing that power from a 90%-efficient switch-mode source, rather than from a much less efficient linear regulator.

## Boost High-Side Gate-Drive Supply (BST3 and BST5)

Gate-drive voltage for the high-side N-channel switches is generated by a flying-capacitor boost circuit (Figure 2). The capacitor between BST<sub>-</sub> and LX<sub>-</sub> is alternately charged from the VL supply and placed parallel to the high-side MOSFET's gate-source terminals.

On start-up, the synchronous rectifier (low-side MOSFET) forces LX<sub>-</sub> to 0V and charges the boost capacitors to 5V. On the second half-cycle, the SMPS

turns on the high-side MOSFET by closing an internal switch between BST<sub>-</sub> and DH<sub>-</sub>. This provides the necessary enhancement voltage to turn on the high-side switch, an action that "boosts" the 5V gate-drive signal above the battery voltage.

Ringings at the high-side MOSFET gate (DH3 and DH5) in discontinuous-conduction mode (light loads) is a natural operating condition. It is caused by residual energy in the tank circuit, formed by the inductor and stray capacitance at the switching node, LX. The gate-drive negative rail is referred to LX, so any ringing there is directly coupled to the gate-drive output.

## Current-Limiting and Current-Sense Inputs (CSH and CSL)

The current-limit circuit resets the main PWM latch and turns off the high-side MOSFET switch whenever the voltage difference between CSH and CSL exceeds 100mV. This limiting is effective for both current flow directions, putting the threshold limit at  $\pm 100$ mV. The tolerance on the positive current limit is  $\pm 20\%$ , so the external low-value sense resistor (R1) must be sized for 80mV/I<sub>PEAK</sub>, where I<sub>PEAK</sub> is the required peak inductor current to support the full load current, while components must be designed to withstand continuous current stresses of 120mV/R1.

For breadboarding or for very-high-current applications, it may be useful to wire the current-sense inputs with a twisted pair, rather than PC traces. (This twisted pair needn't be anything special; two pieces of wire-wrap wire twisted together are sufficient.) This reduces the possible noise picked up at CSH<sub>-</sub> and CSL<sub>-</sub>, which can cause unstable switching and reduced output current.

The CSL5 input also serves as the IC's bootstrap supply input. Whenever V<sub>CSL5</sub> > 4.5V, an internal switch connects CSL5 to VL.

## Oscillator Frequency and Synchronization (SYNC)

The SYNC input controls the oscillator frequency. Low selects 200kHz; high selects 300kHz. SYNC can also be used to synchronize with an external 5V CMOS or TTL clock generator. SYNC has a guaranteed 240kHz to 350kHz capture range. A high-to-low transition on SYNC initiates a new cycle.

300kHz operation optimizes the application circuit for component size and cost. 200kHz operation provides increased efficiency, lower dropout, and improved load-transient response at low input-output voltage differences (see *Low-Voltage Operation* section).

# Multi-Output, Low-Noise Power-Supply Controllers for Notebook Computers

## Shutdown Mode

Holding  $\overline{\text{SHDN}}$  low puts the IC into its 4 $\mu\text{A}$  shutdown mode.  $\overline{\text{SHDN}}$  is logic input with a threshold of about 1V (the  $V_{\text{TH}}$  of an internal N-channel MOSFET). For automatic start-up, bypass  $\overline{\text{SHDN}}$  to GND with a 0.01 $\mu\text{F}$  capacitor and connect it to V+ through a 220k $\Omega$  resistor.

## Power-Up Sequencing and ON/OFF Controls

Start-up is controlled by RUN/ON3 and TIME/ON5 in conjunction with SEQ. With SEQ tied to REF, the two control inputs act as separate ON/OFF controls for each supply. With SEQ tied to VL or GND, RUN/ON3 becomes the master ON/OFF control input and TIME/ON5 becomes a timing pin, with the delay between the two supplies determined by an external capacitor. The delay is approximately 800 $\mu\text{s}/\text{nF}$ . The +3.3V supply powers-up first if SEQ is tied to VL, and the +5V supply is first if SEQ is tied to GND. When driving TIME/ON5 as a control input with external logic, always place a resistor (>1k $\Omega$ ) in series with the input. This prevents possible crowbar current due to the internal discharge pull-down transistor, which turns on in standby mode and momentarily at the first power-up or in shutdown mode.

## RESET Power-Good Voltage Monitor

The power-good monitor generates a system RESET signal. At first power-up, RESET is held low until both the 3.3V and 5V SMPS outputs are in regulation. At this point, an internal timer begins counting oscillator pulses, and RESET continues to be held low until 32,000 cycles have elapsed. After this timeout period (107ms at 300kHz or 160ms at 200kHz), RESET is actively pulled up to VL. If SEQ is tied to REF (for separate ON3/ON5 controls), only the 3.3V SMPS is monitored—the 5V SMPS is ignored.

## Output Undervoltage Shutdown Protection (MAX1630/MAX1631/MAX1632)

The output undervoltage lockout circuit is similar to foldback current limiting, but employs a timer rather than a variable current limit. Each SMPS has an undervoltage protection circuit that is activated 6144 clock cycles after the SMPS is enabled. If either SMPS output is under 70% of the nominal value, both SMPSs are latched off and their outputs are clamped to ground by the synchronous rectifier MOSFETs (see *Output Overvoltage Protection* section). They won't restart until  $\overline{\text{SHDN}}$  or RUN/ON3 is toggled, or until V+ power is cycled below 1V. Note that undervoltage protection can make prototype troubleshooting difficult, since you have only 20ms or 30ms to figure out what might be wrong with the circuit before both SMPSs are latched off. In extreme cases, it may be useful to substitute the MAX1633/MAX1634/MAX1635 into the prototype breadboard until the prototype is working properly.

## Output Overvoltage Protection (MAX1630/MAX1631/MAX1632)

Both SMPS outputs are monitored for overvoltage. If either output is more than 7% above the nominal regulation point, both low-side gate drivers (DL\_) are latched high until  $\overline{\text{SHDN}}$  or RUN/ON3 is toggled, or until V+ power is cycled below 1V. This action turns on the synchronous rectifiers with 100% duty, in turn rapidly discharging the output capacitors and forcing both SMPS outputs to ground. The DL outputs are also kept high whenever the corresponding SMPS is disabled, and in shutdown if VL is sustained.

**Table 4. Operating Modes**

$\overline{\text{SHDN}}$	SEQ	RUN/ON3	TIME/ON5	MODE	DESCRIPTION
Low	X	X	X	Shutdown	All circuit blocks turned off. Supply current = 4 $\mu\text{A}$ .
High	Ref	Low	Low	Standby	Both SMPSs off. Supply current = 30 $\mu\text{A}$ .
High	Ref	High	Low	Run	3.3V SMPS enabled/5V off
High	Ref	Low	High	Run	5V SMPS enabled/3.3V off
High	Ref	High	High	Run	Both SMPSs enabled
High	GND	Low	Timing capacitor	Standby	Both SMPSs off. Supply current = 30 $\mu\text{A}$ .
High	GND	High	Timing capacitor	Run	Both SMPSs enabled. 5V enabled before 3.3V.
High	VL	Low	Timing capacitor	Standby	Both SMPSs off. Supply current = 30 $\mu\text{A}$ .
High	VL	High	Timing capacitor	Run	Both SMPSs enabled. 3.3V enabled before 5V.

X = Don't Care

# Multi-Output, Low-Noise Power-Supply Controllers for Notebook Computers

Discharging the output capacitor through the main inductor causes the output to momentarily go below GND. Clamp this negative pulse with a back-biased 1A Schottky diode across the output capacitor (Figure 1).

To ensure overvoltage protection on initial power-up, connect signal diodes from both output voltages to VL (cathodes to VL) to eliminate the VL power-up delay. This circuitry protects the load from accidental overvoltage caused by a short-circuit across the high-side power MOSFETs. This scheme relies on the presence of a fuse, in series with the battery, which is blown by the resulting crowbar current. Note that the overvoltage circuitry will interfere with external keep-alive supplies that hold up the outputs (such as lithium backup or hot-swap power supplies); in such cases, the MAX1633, MAX1634, or MAX1635 should be used.

## Low-Noise Operation (PWM Mode)

PWM mode ( $\overline{\text{SKIP}} = \text{high}$ ) minimizes RF and audio interference in noise-sensitive applications (such as hi-fi multimedia-equipped systems), cellular phones, RF communicating computers, and electromagnetic penetration systems. See the summary of operating modes in Table 2.  $\overline{\text{SKIP}}$  can be driven from an external logic signal.

Interference due to switching noise is reduced in PWM mode by ensuring a constant switching frequency, thus concentrating the emissions at a known frequency outside the system audio or IF bands. Choose an oscillator frequency for which switching frequency harmonics don't overlap a sensitive frequency band. If necessary, synchronize the oscillator to a tight-tolerance external clock generator. To extend the output-voltage-regulation range, constant operating frequency is not maintained under overload or dropout conditions (see *Overload and Dropout Operation* section.)

PWM mode ( $\overline{\text{SKIP}} = \text{high}$ ) forces two changes upon the PWM controllers. First, it disables the minimum-current comparator, ensuring fixed-frequency operation. Second, it changes the detection threshold for reverse-current limit from 0mV to -100mV, allowing the inductor current to reverse at light loads. This results in fixed-frequency operation and continuous inductor-current flow. This eliminates discontinuous-mode inductor ringing and improves cross regulation of transformer-coupled multiple-output supplies, particularly in circuits that don't use additional secondary regulation via SECFB or VDD.

In most applications, tie  $\overline{\text{SKIP}}$  to GND to minimize quiescent supply current. VL supply current with  $\overline{\text{SKIP}}$  high is typically 20mA, depending on external MOSFET gate capacitance and switching losses.

## Internal Digital Soft-Start Circuit

Soft-start allows a gradual increase of the internal current-limit level at start-up to reduce input surge currents. Both SMPSs contain internal digital soft-start circuits, each controlled by a counter, a digital-to-analog converter (DAC), and a current-limit comparator. In shutdown or standby mode, the soft-start counter is reset to zero. When an SMPS is enabled, its counter starts counting oscillator pulses, and the DAC begins incrementing the comparison voltage applied to the current-limit comparator. The DAC output increases from 0mV to 100mV in five equal steps as the count increases to 512 clocks. As a result, the main output capacitor charges up relatively slowly. The exact time of the output rise depends on output capacitance and load current, and is typically 1ms with a 300kHz oscillator.

## Dropout Operation

Dropout (low input-output differential operation) is enhanced by stretching the clock pulse width to increase the maximum duty factor. The algorithm follows: If the output voltage (VOUT) drops out of regulation without the current limit having been reached, the SMPS skips an off-time period (extending the on-time). At the end of the cycle, if the output is still out of regulation, the SMPS skips another off-time period. This action can continue until three off-time periods are skipped, effectively dividing the clock frequency by as much as four.

The typical PWM minimum off-time is 300ns, regardless of the operating frequency. Lowering the operating frequency raises the maximum duty factor above 98%.

## Adjustable-Output Feedback (Dual Mode FB)

Fixed, preset output voltages are selected when FB<sub>-</sub> is connected to ground. Adjusting the main output voltage with external resistors is simple for any of the MAX1630 family ICs, through resistor dividers connected to FB3 and FB5 (Figure 2). Calculate the output voltage with the following formula:

$$V_{\text{OUT}} = V_{\text{REF}} (1 + R_1 / R_2)$$

where  $V_{\text{REF}} = 2.5\text{V}$  nominal.

The nominal output should be set approximately 1% or 2% high to make up for the MAX1630's -2% typical load-regulation error. For example, if designing for a 3.0V output, use a resistor ratio that results in a nominal output voltage of 3.05V. This slight offsetting gives the best possible accuracy. Recommended normal values for R2 range from 5k $\Omega$  to 100k $\Omega$ . To achieve a 2.5V nominal output, simply connect FB<sub>-</sub> directly to CSL<sub>-</sub>.



# Multi-Output, Low-Noise Power-Supply Controllers for Notebook Computers

MAX1630-MAX1635

Remote output-voltage sensing, while not possible in fixed-output mode due to the combined nature of the voltage-sense and current-sense inputs (CSL3 and CSL5), is easy to do in adjustable mode by using the top of the external resistor divider as the remote sense point.

When using adjustable mode, it is a good idea to always set the “3.3V output” to a lower voltage than the “5V output.” The 3.3V output must always be less than VL, so that the voltage on CSH3 and CSL3 is within the common-mode range of the current-sense inputs. While VL is nominally 5V, it can be as low as 4.7V when linearly regulating, and as low as 4.2V when automatically bootstrapped to CSH5.

## Secondary Feedback Regulation Loop (SECFB or VDD)

A flyback-winding control loop regulates a secondary winding output, improving cross-regulation when the primary output is lightly loaded or when there is a low input-output differential voltage. If VDD or SECFB falls below its regulation threshold, the low-side switch is turned on for an extra 1μs. This reverses the inductor (primary) current, pulling current from the output filter capacitor and causing the flyback transformer to operate in forward mode. The low impedance presented by the transformer secondary in forward mode dumps current into the secondary output, charging up the secondary capacitor and bringing VDD or SECFB back into regulation. The secondary feedback loop does not improve secondary output accuracy in normal flyback mode, where the main (primary) output is heavily loaded. In this condition, secondary output accuracy is determined by the secondary rectifier drop, transformer turns ratio, and accuracy of the main output voltage. A linear post-regulator may still be needed to meet strict output-accuracy specifications.

Devices with a 12OUT linear regulator have a VDD pin that regulates at a fixed 13.5V, set by an internal resistor divider. The MAX1631/MAX1634 have an adjustable secondary output voltage set by an external resistor divider on SECFB (Figure 5). Ordinarily, the secondary regulation point is set 5% to 10% below the voltage normally produced by the flyback effect. For example, if the output voltage as determined by turns ratio is 15V, set the feedback resistor ratio to produce 13.5V. Otherwise, the SECFB one-shot might be triggered unintentionally, unnecessarily increasing supply current and output noise.

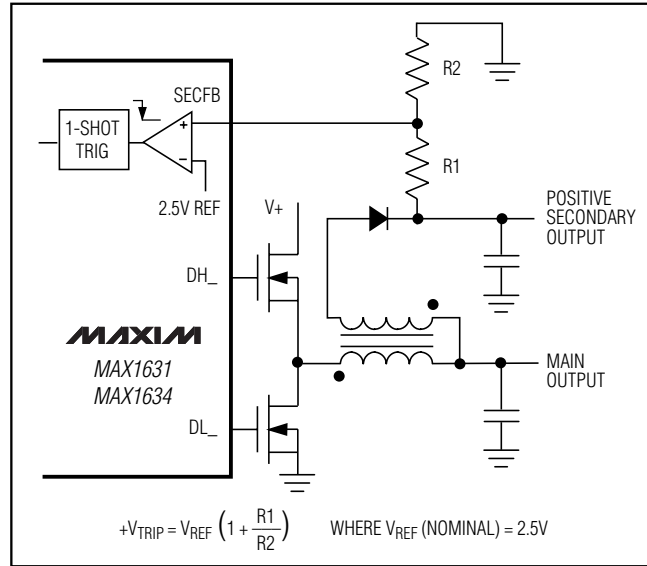

Figure 5. Adjusting the Secondary Output Voltage with SECFB

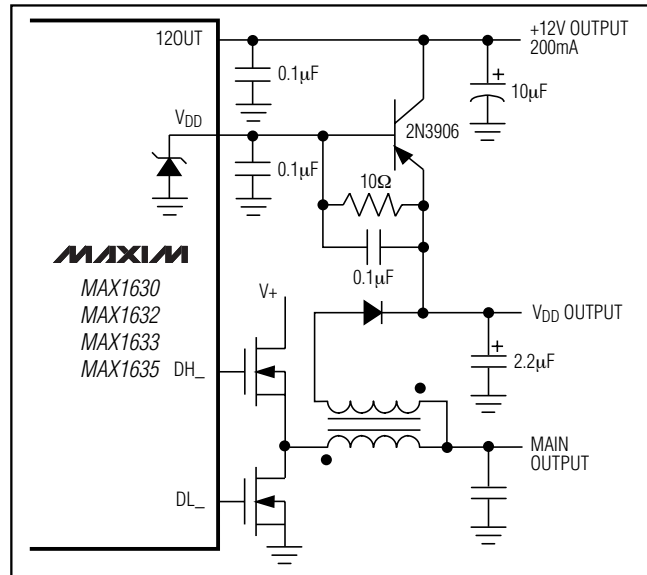

Figure 6. Increased 12V Linear Regulator Output Current

## 12V Linear Regulator Output (MAX1630/MAX1632/MAX1633/MAX1635)

The MAX1630/MAX1632/MAX1633/MAX1635 include a 12V linear regulator output capable of delivering 120mA of output current. Typically, greater current is available at the expense of output accuracy. If an accurate output of more than 120mA is needed, an external pass tran-

# Multi-Output, Low-Noise Power-Supply Controllers for Notebook Computers

sistor can be added. Figure 6's circuit delivers more than 200mA. Total output current is constrained by the V+ input voltage and the transformer primary load (see Maximum 15V V<sub>DD</sub> Output Current vs. Supply Voltage graphs in the *Typical Operating Characteristics*).

## Design Procedure

The three predesigned 3V/5V standard application circuits (Figure 1 and Table 1) contain ready-to-use solutions for common application needs. Also, two standard flyback transformer circuits support the 12OUT linear regulator in the *Applications Information* section. Use the following design procedure to optimize these basic schematics for different voltage or current requirements. But before beginning a design, firmly establish the following:

**Maximum input (battery) voltage, V<sub>IN(MAX)</sub>.** This value should include the worst-case conditions, such as no-load operation when a battery charger or AC adapter is connected but no battery is installed. V<sub>IN(MAX)</sub> must not exceed 30V.

**Minimum input (battery) voltage, V<sub>IN(MIN)</sub>.** This should be taken at full load under the lowest battery conditions. If V<sub>IN(MIN)</sub> is less than 4.2V, use an external circuit to externally hold V<sub>L</sub> above the V<sub>L</sub> undervoltage lockout threshold. If the minimum input-output difference is less than 1.5V, the filter capacitance required to maintain good AC load regulation increases (see *Low-Voltage Operation* section).

## Inductor Value

The exact inductor value isn't critical and can be freely adjusted to make trade-offs between size, cost, and efficiency. Lower inductor values minimize size and cost, but reduce efficiency due to higher peak-current levels. The smallest inductor is achieved by lowering the inductance until the circuit operates at the border between continuous and discontinuous mode. Further reducing the inductor value below this crossover point results in discontinuous-conduction operation even at full load. This helps lower output filter capacitance requirements, but efficiency suffers due to high I<sup>2</sup>R losses. On the other hand, higher inductor values mean greater efficiency, but resistive losses due to extra wire turns will eventually exceed the benefit gained from lower peak-current levels. Also, high inductor values can affect load-transient response (see the V<sub>SAG</sub> equation in the *Low-Voltage Operation* section). The equations that follow are for continuous-conduction operation, since the MAX1630 family is intended mainly

for high-efficiency, battery-powered applications. See Appendix A in Maxim's *Battery Management and DC-DC Converter Circuit Collection* for crossover-point and discontinuous-mode equations. Discontinuous conduction doesn't affect normal Idle Mode operation.

Three key inductor parameters must be specified: inductance value (L), peak current (I<sub>PEAK</sub>), and DC resistance (R<sub>DC</sub>). The following equation includes a constant, LIR, which is the ratio of inductor peak-to-peak AC current to DC load current. A higher LIR value allows smaller inductance, but results in higher losses and higher ripple. A good compromise between size and losses is found at a 30% ripple-current to load-current ratio (LIR = 0.3), which corresponds to a peak inductor current 1.15 times higher than the DC load current.

$$L = \frac{V_{OUT}(V_{IN(MAX)} - V_{OUT})}{V_{IN(MAX)} \times f \times I_{OUT} \times LIR}$$

where: f = switching frequency, normally 200kHz or 300kHz

I<sub>OUT</sub> = maximum DC load current

LIR = ratio of AC to DC inductor current, typically 0.3; should be selected for >0.15

The nominal peak inductor current at full load is 1.15 x I<sub>OUT</sub> if the above equation is used; otherwise, the peak current can be calculated by:

$$I_{PEAK} = I_{LOAD} + \frac{V_{OUT}(V_{IN(MAX)} - V_{OUT})}{2 \times f \times L \times V_{IN(MAX)}}$$

The inductor's DC resistance should be low enough that R<sub>DC</sub> x I<sub>PEAK</sub> < 100mV, as it is a key parameter for efficiency performance. If a standard off-the-shelf inductor is not available, choose a core with an LI<sup>2</sup> rating greater than L x I<sub>PEAK</sub><sup>2</sup> and wind it with the largest-diameter wire that fits the winding area. For 300kHz applications, ferrite core material is strongly preferred; for 200kHz applications, Kool-Mu® (aluminum alloy) or even powdered iron is acceptable. If light-load efficiency is unimportant (in desktop PC applications, for example), then low-permeability iron-powder cores, such as the Micrometals type found in Pulse Engineering's 2.1μH PE-53680, may be acceptable even at 300kHz. For high-current applications, shielded-core geometries, such as toroidal or pot core, help keep noise, EMI, and switching-waveform jitter low.

*Kool-Mu is a registered trademark of Magnetics Div., Spang & Co.*

# Multi-Output, Low-Noise Power-Supply Controllers for Notebook Computers

## Current-Sense Resistor Value

The current-sense resistor value is calculated according to the worst-case-low current-limit threshold voltage (from the *Electrical Characteristics* table) and the peak inductor current:

$$R_{\text{SENSE}} = \frac{80\text{mV}}{I_{\text{PEAK}}}$$

Use  $I_{\text{PEAK}}$  from the second equation in the *Inductor Value* section

Use the calculated value of  $R_{\text{SENSE}}$  to size the MOSFET switches and specify inductor saturation-current ratings according to the worst-case high-current-limit threshold voltage:

$$I_{\text{PEAK(MAX)}} = \frac{120\text{mV}}{R_{\text{SENSE}}}$$

Low-inductance resistors, such as surface-mount metal-film, are recommended.

## Input Capacitor Value

Connect low-ESR bulk capacitors and small ceramic capacitors (0.1 $\mu\text{F}$ ) directly to the drains on the high-side MOSFETs. The bulk input filter capacitor is usually selected according to input ripple current requirements and voltage rating, rather than capacitor value. Electrolytic capacitors with low enough effective series resistance (ESR) to meet the ripple current requirement invariably have sufficient capacitance values. Aluminum electrolytic capacitors, such as Sanyo OS-CON or Nichicon PL, are superior to tantalum types, which carry the risk of power-up surge-current failure, especially when connecting to robust AC adapters or low-impedance batteries. RMS input ripple current ( $I_{\text{RMS}}$ ) is determined by the input voltage and load current, with the worst case occurring at  $V_{\text{IN}} = 2 \times V_{\text{OUT}}$ :

$$I_{\text{RMS}} = I_{\text{LOAD}} \times \frac{\sqrt{V_{\text{OUT}}(V_{\text{IN}} - V_{\text{OUT}})}}{V_{\text{IN}}}$$

Therefore, when  $V_{\text{IN}}$  is  $2 \times V_{\text{OUT}}$ :

$$I_{\text{RMS}} = \frac{I_{\text{LOAD}}}{2}$$

## Bypassing V+

Bypass the V+ input with a 4.7 $\mu\text{F}$  tantalum capacitor paralleled with a 0.1 $\mu\text{F}$  ceramic capacitor, close to the IC. A 10 $\Omega$  series resistor to  $V_{\text{IN}}$  is also recommended.

## Bypassing VL

Bypass the VL output with a 4.7 $\mu\text{F}$  tantalum capacitor paralleled with a 0.1 $\mu\text{F}$  ceramic capacitor, close to the device.

## Output Filter Capacitor Value

The output filter capacitor values are generally determined by the ESR and voltage rating requirements, rather than actual capacitance requirements for loop stability. In other words, the low-ESR electrolytic capacitor that meets the ESR requirement usually has more output capacitance than is required for AC stability. Use only specialized low-ESR capacitors intended for switching-regulator applications, such as AVX TPS, Sprague 595D, Sanyo OS-CON, or Nichicon PL series. To ensure stability, the capacitor must meet *both* minimum capacitance and maximum ESR values as given in the following equations:

$$C_{\text{OUT}} > \frac{V_{\text{REF}}(1 + V_{\text{OUT}} / V_{\text{IN(MIN)}})}{V_{\text{OUT}} \times R_{\text{SENSE}} \times f}$$

$$R_{\text{ESR}} < \frac{R_{\text{SENSE}} \times V_{\text{OUT}}}{V_{\text{REF}}}$$

(can be multiplied by 1.5; see text below)

These equations are worst case, with 45 degrees of phase margin to ensure jitter-free, fixed-frequency operation and provide a nicely damped output response for zero to full-load step changes. Some cost-conscious designers may wish to bend these rules with less-expensive capacitors, particularly if the load lacks large step changes. This practice is tolerable if some bench testing over temperature is done to verify acceptable noise and transient response.

No well-defined boundary exists between stable and unstable operation. As phase margin is reduced, the first symptom is a bit of timing jitter, which shows up as blurred edges in the switching waveforms where the scope won't quite sync up. Technically speaking, this jitter (usually harmless) is unstable operation, since the duty factor varies slightly. As capacitors with higher ESRs are used, the jitter becomes more pronounced, and the load-transient output voltage waveform starts looking ragged at the edges. Eventually, the load-transient waveform has enough ringing on it that the peak noise levels exceed the allowable output voltage tolerance. Note that even with zero phase margin and gross instability present, the output voltage noise never gets much worse than  $I_{\text{PEAK}} \times R_{\text{ESR}}$  (under constant loads).

Designers of RF communicators or other noise-sensitive analog equipment should be conservative and stay within the guidelines. Designers of notebook computers and similar commercial-temperature-range digital

# Multi-Output, Low-Noise Power-Supply Controllers for Notebook Computers

systems can multiply the  $R_{ESR}$  value by a factor of 1.5 without hurting stability or transient response.

The output voltage ripple is usually dominated by the filter capacitor's ESR, and can be approximated as  $I_{RIPPLE} \times R_{ESR}$ . There is also a capacitive term, so the full equation for ripple in continuous-conduction mode is  $V_{NOISE(p-p)} = I_{RIPPLE} \times [R_{ESR} + 1/(2 \times \pi \times f \times C_{OUT})]$ . In Idle Mode, the inductor current becomes discontinuous, with high peaks and widely spaced pulses, so the noise can actually be higher at light load (compared to full load). In Idle Mode, calculate the output ripple as follows:

$$V_{NOISE(p-p)} = \frac{0.02 \times R_{ESR}}{R_{SENSE}} + \frac{0.0003 \times L_x \left[ 1 / V_{OUT} + 1 / (V_{IN} - V_{OUT}) \right]}{(R_{SENSE})^2 \times C_{OUT}}$$

## Transformer Design (for Auxiliary Outputs Only)

Buck-plus-flyback applications, sometimes called "coupled-inductor" topologies, need a transformer to generate multiple output voltages. Performing the basic electrical design is a simple task of calculating turns ratios and adding the power delivered to the secondary to calculate the current-sense resistor and primary inductance. However, extremes of low input-output differentials, widely different output loading levels, and high turns ratios can complicate the design due to parasitic transformer parameters such as interwinding capacitance, secondary resistance, and leakage inductance. For examples of what is possible with real-world transformers, see the Maximum Secondary Current vs. Input Voltage graph in the *Typical Operating Characteristics* section.

Power from the main and secondary outputs is combined to get an equivalent current referred to the main output voltage (see the *Inductor Value* section for parameter definitions). Set the current-sense resistor resistor value at  $80mV / I_{TOTAL}$ .

$P_{TOTAL}$  = The sum of the output power from all outputs

$I_{TOTAL} = P_{TOTAL} / V_{OUT}$  = The equivalent output current referred to  $V_{OUT}$

$$L(\text{primary}) = \frac{V_{OUT}(V_{IN(\text{MAX})} - V_{OUT})}{V_{IN(\text{MAX})} \times f \times I_{TOTAL} \times LIR}$$

$$\text{Turns Ratio } N = \frac{V_{SEC} + V_{FWD}}{V_{OUT(\text{MIN})} + V_{RECT} + V_{SENSE}}$$

where:  $V_{SEC}$  = the minimum required rectified secondary output voltage

$V_{FWD}$  = the forward drop across the secondary rectifier

$V_{OUT(\text{MIN})}$  = the *minimum* value of the main output voltage (from the *Electrical Characteristics*)

$V_{RECT}$  = the on-state voltage drop across the synchronous rectifier MOSFET

$V_{SENSE}$  = the voltage drop across the sense resistor

In positive-output applications, the transformer secondary return is often referred to the main output voltage, rather than to ground, to reduce the needed turns ratio. In this case, the main output voltage must first be subtracted from the secondary voltage to obtain  $V_{SEC}$ .

## Selecting Other Components

### MOSFET Switches

The high-current N-channel MOSFETs must be logic-level types with guaranteed on-resistance specifications at  $V_{GS} = 4.5V$ . Lower gate threshold specifications are better (i.e., 2V max rather than 3V max). Drain-source breakdown voltage ratings must at least equal the maximum input voltage, preferably with a 20% derating factor. The best MOSFETs will have the lowest on-resistance per nanocoulomb of gate charge. Multiplying  $R_{DS(ON)} \times Q_G$  provides a good figure for comparing various MOSFETs. Newer MOSFET process technologies with dense cell structures generally perform best. The internal gate drivers tolerate  $>100nC$  total gate charge, but 70nC is a more practical upper limit to maintain best switching times.

In high-current applications, MOSFET package power dissipation often becomes a dominant design factor.  $I^2R$  power losses are the greatest heat contributor for both high-side and low-side MOSFETs.  $I^2R$  losses are distributed between Q1 and Q2 according to duty factor (see the following equations). Generally, switching losses affect only the upper MOSFET, since the Schottky rectifier clamps the switching node in most cases before the synchronous rectifier turns on. Gate-charge losses are dissipated by the driver and don't heat the MOSFET. Calculate the temperature rise according to package thermal-resistance specifications to ensure that both MOSFETs are within their maximum junction temperature at high ambient temperature. The worst-case dissipation for the high-side MOSFET occurs at both extremes of input voltage, and the worst-case dissipation for the low-side MOSFET occurs at maximum input voltage.

# Multi-Output, Low-Noise Power-Supply Controllers for Notebook Computers

$$PD(\text{upper FET}) = (I_{\text{LOAD}})^2 \times R_{\text{DS(ON)}} \times \text{DUTY} \\ + V_{\text{IN}} \times I_{\text{LOAD}} \times f \times \left( \frac{V_{\text{IN}} \times C_{\text{RSS}}}{I_{\text{GATE}}} + 20\text{ns} \right)$$

$$PD(\text{lower FET}) = (I_{\text{LOAD}})^2 \times R_{\text{DS(ON)}} \times (1 - \text{DUTY})$$

$$\text{DUTY} = (V_{\text{OUT}} + V_{\text{Q2}}) / (V_{\text{IN}} - V_{\text{Q1}})$$

where: on-state voltage drop  $V_{\text{Q}_-} = I_{\text{LOAD}} \times R_{\text{DS(ON)}}$

$C_{\text{RSS}}$  = MOSFET reverse transfer capacitance

$I_{\text{GATE}}$  = DH driver peak output current capability (1A typical)

20ns = DH driver inherent rise/fall time

Under output short-circuit, the MAX1633/MAX1634/MAX1635's synchronous rectifier MOSFET suffers extra stress because its duty factor can increase to greater than 0.9. It may need to be oversized to tolerate a continuous DC short circuit. During short circuit, the MAX1630/MAX1631/MAX1632's output undervoltage shutdown protects the synchronous rectifier under output short-circuit conditions.

To reduce EMI, add a 0.1 $\mu$ F ceramic capacitor from the high-side switch drain to the low-side switch source.

## Rectifier Clamp Diode

The rectifier is a clamp across the low-side MOSFET that catches the negative inductor swing during the 60ns dead time between turning one MOSFET off and each low-side MOSFET on. The latest generations of MOSFETs incorporate a high-speed silicon body diode, which serves as an adequate clamp diode if efficiency is not of primary importance. A Schottky diode can be placed in parallel with the body diode to reduce the forward voltage drop, typically improving efficiency 1% to 2%. Use a diode with a DC current rating equal to one-third of the load current; for example, use an MBR0530 (500mA-rated) type for loads up to 1.5A, a 1N5819 type for loads up to 3A, or a 1N5822 type for loads up to 10A. The rectifier's rated reverse breakdown voltage must be at least equal to the maximum input voltage, preferably with a 20% derating factor.

## Boost-Supply Diode D2

A signal diode such as a 1N4148 works well in most applications. If the input voltage can go below +6V, use a small (20mA) Schottky diode for slightly improved efficiency and dropout characteristics. Don't use large power diodes, such as 1N5817 or 1N4001, since high junction capacitance can pump up VL to excessive voltages.

## Rectifier Diode D3 (Transformer Secondary Diode)

The secondary diode in coupled-inductor applications must withstand flyback voltages greater than 60V, which usually rules out most Schottky rectifiers. Common silicon rectifiers, such as the 1N4001, are also prohibited because they are too slow. This often makes fast silicon rectifiers such as the MURS120 the only choice. The flyback voltage across the rectifier is related to the  $V_{\text{IN}} - V_{\text{OUT}}$  difference, according to the transformer turns ratio:

$$V_{\text{FLYBACK}} = V_{\text{SEC}} + (V_{\text{IN}} - V_{\text{OUT}}) \times N$$

where: N = the transformer turns ratio SEC/PRI

$V_{\text{SEC}}$  = the maximum secondary DC output voltage

$V_{\text{OUT}}$  = the primary (main) output voltage

Subtract the main output voltage ( $V_{\text{OUT}}$ ) from  $V_{\text{FLYBACK}}$  in this equation if the secondary winding is returned to  $V_{\text{OUT}}$  and not to ground. The diode reverse breakdown rating must also accommodate any ringing due to leakage inductance. D3's current rating should be at least twice the DC load current on the secondary output.

## Low-Voltage Operation

Low input voltages and low input-output differential voltages each require extra care in their design. Low absolute input voltages can cause the VL linear regulator to enter dropout and eventually shut itself off. Low input voltages relative to the output (low  $V_{\text{IN}} - V_{\text{OUT}}$  differential) can cause bad load regulation in multi-output flyback applications (see the design equations in the *Transformer Design* section). Also, low  $V_{\text{IN}} - V_{\text{OUT}}$  differentials can also cause the output voltage to sag when the load current changes abruptly. The amplitude of the sag is a function of inductor value and maximum duty factor (an *Electrical Characteristics* parameter, 98% guaranteed over temperature at  $f = 200\text{kHz}$ ), as follows:

$$V_{\text{SAG}} = \frac{(I_{\text{STEP}})^2 \times L}{2 \times C_{\text{OUT}} \times (V_{\text{IN(MAX)}} \times D_{\text{MAX}} - V_{\text{OUT}})}$$

The cure for low-voltage sag is to increase the output capacitor's value. For example, at  $V_{\text{IN}} = +5.5\text{V}$ ,  $V_{\text{OUT}} = +5\text{V}$ ,  $L = 10\mu\text{H}$ ,  $f = 200\text{kHz}$ ,  $I_{\text{STEP}} = 3\text{A}$ , a total capacitance of 660 $\mu\text{F}$  keeps the sag less than 200mV. Note that only the capacitance requirement increases, and the ESR requirements don't change. Therefore, the added capacitance can be supplied by a low-cost bulk capacitor in parallel with the normal low-ESR capacitor.

# Multi-Output, Low-Noise Power-Supply Controllers for Notebook Computers

Table 5. Low-Voltage Troubleshooting Chart

SYMPTOM	CONDITION	ROOT CAUSE	SOLUTION
Sag or droop in $V_{OUT}$ under step-load change	Low $V_{IN}$ - $V_{OUT}$ differential, <1.5V	Limited inductor-current slew rate per cycle.	Increase bulk output capacitance per formula (see <i>Low-Voltage Operation</i> section). Reduce inductor value.
Dropout voltage is too high ( $V_{OUT}$ follows $V_{IN}$ as $V_{IN}$ decreases)	Low $V_{IN}$ - $V_{OUT}$ differential, <1V	Maximum duty-cycle limits exceeded.	Reduce operation to 200kHz. Reduce MOSFET on-resistance and coil DCR.
Unstable—jitters between different duty factors and frequencies	Low $V_{IN}$ - $V_{OUT}$ differential, <0.5V	Normal function of internal low-dropout circuitry.	Increase the minimum input voltage or ignore.
Secondary output won't support a load	Low $V_{IN}$ - $V_{OUT}$ differential, $V_{IN} < 1.3 \times V_{OUT}$ (main)	Not enough duty cycle left to initiate forward-mode operation. Small AC current in primary can't store energy for flyback operation.	Reduce operation to 200kHz. Reduce secondary impedances; use a Schottky diode, if possible. Stack secondary winding on the main output.
Poor efficiency	Low input voltage, <5V	VL linear regulator is going into dropout and isn't providing good gate-drive levels.	Use a small 20mA Schottky diode for boost diode D2. Supply VL from an external source.
Won't start under load or quits before battery is completely dead	Low input voltage, <4.5V	VL output is so low that it hits the VL UVLO threshold.	Supply VL from an external source other than $V_{IN}$ , such as the system +5V supply.

## Applications Information

### Heavy-Load Efficiency Considerations

The major efficiency-loss mechanisms under loads are, in the usual order of importance:

- $P(I^2R) = I^2R$  losses
- $P(\text{tran}) =$  transition losses
- $P(\text{gate}) =$  gate-charge losses
- $P(\text{diode}) =$  diode-conduction losses
- $P(\text{cap}) =$  capacitor ESR losses
- $P(\text{IC}) =$  losses due to the IC's operating supply current

Inductor core losses are fairly low at heavy loads because the inductor's AC current component is small. Therefore, they aren't accounted for in this analysis. Ferrite cores are preferred, especially at 300kHz, but powdered cores, such as Kool-Mu, can work well.

$$\begin{aligned} \text{Efficiency} &= P_{OUT} / P_{IN} \times 100\% \\ &= P_{OUT} / (P_{OUT} + P_{TOTAL}) \times 100\% \end{aligned}$$

$$P_{TOTAL} = P(I^2R) + P(\text{tran}) + P(\text{gate}) + P(\text{diode}) + P(\text{cap}) + P(\text{IC})$$

$$P = (I^2R) = (I_{LOAD})^2 \times (R_{DC} + R_{DS(ON)} + R_{SENSE})$$

where  $R_{DC}$  is the DC resistance of the coil,  $R_{DS(ON)}$  is the MOSFET on-resistance, and  $R_{SENSE}$  is the current-sense resistor value. The  $R_{DS(ON)}$  term assumes identical MOSFETs for the high-side and low-side switches, because they time-share the inductor current. If the MOSFETs aren't identical, their losses can be estimated by averaging the losses according to duty factor.

$$PD(\text{tran}) = \text{transition loss} = V_{IN} \times I_{LOAD} \times f \times \frac{3}{2} \times [(V_{IN} \times C_{RSS} / I_{GATE}) + 20\text{ns}]$$

where  $C_{RSS}$  is the reverse transfer capacitance of the high-side MOSFET (a data-sheet parameter),  $I_{GATE}$  is the DH gate-driver peak output current (1.5A typical), and 20ns is the rise/fall time of the DH driver (20ns typical).

$$P(\text{gate}) = qG \times f \times VL$$

where VL is the internal-logic-supply voltage (+5V), and qG is the sum of the gate-charge values for low-side and high-side switches. For matched MOSFETs, qG is twice the data-sheet value of an individual MOSFET. If  $V_{OUT}$  is set to less than 4.5V, replace VL in this equation with  $V_{BATT}$ . In this case, efficiency can be improved by connecting VL to an efficient 5V source, such as the system +5V supply.

$$\begin{aligned} P(\text{diode}) &= \text{diode-conduction losses} \\ &= I_{LOAD} \times V_{FWD} \times t_D \times f \end{aligned}$$

# Multi-Output, Low-Noise Power-Supply Controllers for Notebook Computers

where  $t_D$  is the diode-conduction time (120ns typical) and  $V_{FWD}$  is the forward voltage of the diode.

This power is dissipated in the MOSFET body diode if no external Schottky diode is used.

$$P(\text{cap}) = \text{input capacitor ESR loss} = (I_{RMS})^2 \times R_{ESR}$$

where  $I_{RMS}$  is the input ripple current as calculated in the *Design Procedure* and *Input Capacitor Value* sections.

## Light-Load Efficiency Considerations

Under light loads, the PWM operates in discontinuous mode, where the inductor current discharges to zero at some point during the switching cycle. This makes the inductor current's AC component high compared to the load current, which increases core losses and  $I^2R$  losses in the output filter capacitors. For best light-load efficiency, use MOSFETs with moderate gate-charge levels, and use ferrite, MPP, or other low-loss core material. Avoid powdered-iron cores; even Kool-Mu (aluminum alloy) is not as good as ferrite.

## PC Board Layout Considerations

Good PC board layout is *required* in order to achieve specified noise, efficiency, and stability performance. The PC board layout artist must be given explicit instructions, preferably a pencil sketch showing the placement of power-switching components and high-current routing. See the PC board layout in the MAX1630 Evaluation Kit manual for examples. A ground plane is essential for optimum performance. In most applications, the circuit will be located on a multi-layer board, and full use of the four or more copper layers is recommended. Use the top layer for high-current connections, the bottom layer for quiet connections (REF, SS, GND), and the inner layers for an uninterrupted ground plane. Use the following step-by-step guide:

- 1) Place the high-power components (Figure 1, C1, C3, Q1, Q2, D1, L1, and R1) first, with any grounded connections adjacent.

Priority 1: **Minimize current-sense resistor trace lengths** and ensure accurate current sensing with Kelvin connections (Figure 7).

Priority 2: **Minimize ground trace lengths** in the high-current paths (discussed below).

Priority 3: Minimize other trace lengths in the high-current paths.

Use >5mm-wide traces

$C_{IN}$  to high-side MOSFET drain: 10mm max length

Rectifier diode cathode to low-side MOSFET: 5mm max length

LX node (MOSFETs, rectifier cathode, inductor): 15mm max length

Ideally, surface-mount power components are butted up to one another with their ground terminals almost touching. These high-current grounds are then connected to each other with a wide filled zone of top-layer copper so they don't go through vias. The resulting top-layer "sub-ground-plane" is connected to the normal inner-layer ground plane at the output ground terminals, which ensures that the IC's analog ground is sensing at the supply's output terminals without interference from IR drops and ground noise. Other high-current paths should also be minimized, but **focusing primarily on short ground and current-sense connections eliminates about 90% of all PC board layout problems** (see the PC board layouts in the MAX1630 Evaluation Kit manual for examples).

- 2) Place the IC and signal components. Keep the main switching nodes (LX nodes) away from sensitive analog components (current-sense traces and REF capacitor). Place the IC and analog components on the opposite side of the board from the power-switching node. **Important:** the IC must be no farther than 10mm from the current-sense resistors. Keep the gate-drive traces (DH\_, DL\_, and BST\_) shorter than 20mm and route them away from CSH\_, CSL\_, and REF.
- 3) Use a single-point star ground where the input ground trace, power ground (sub-ground-plane), and normal ground plane meet at the supply's output ground terminal. Connect both IC ground pins and all IC bypass capacitors to the normal ground plane.

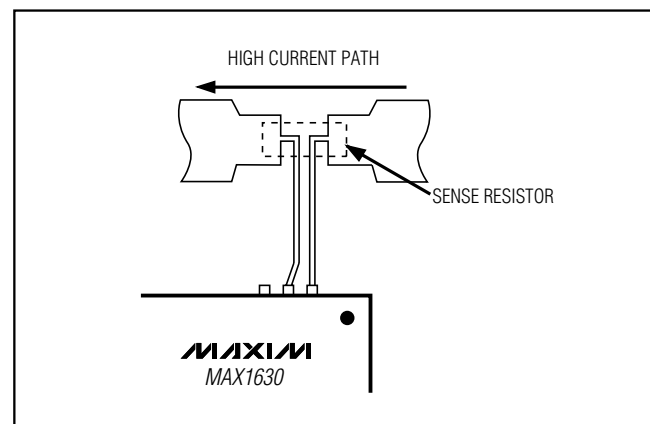

Figure 7. Kelvin Connections for the Current-Sense Resistors

# Multi-Output, Low-Noise Power-Supply Controllers for Notebook Computers

## Application Circuits

MAX1630-MAX1635

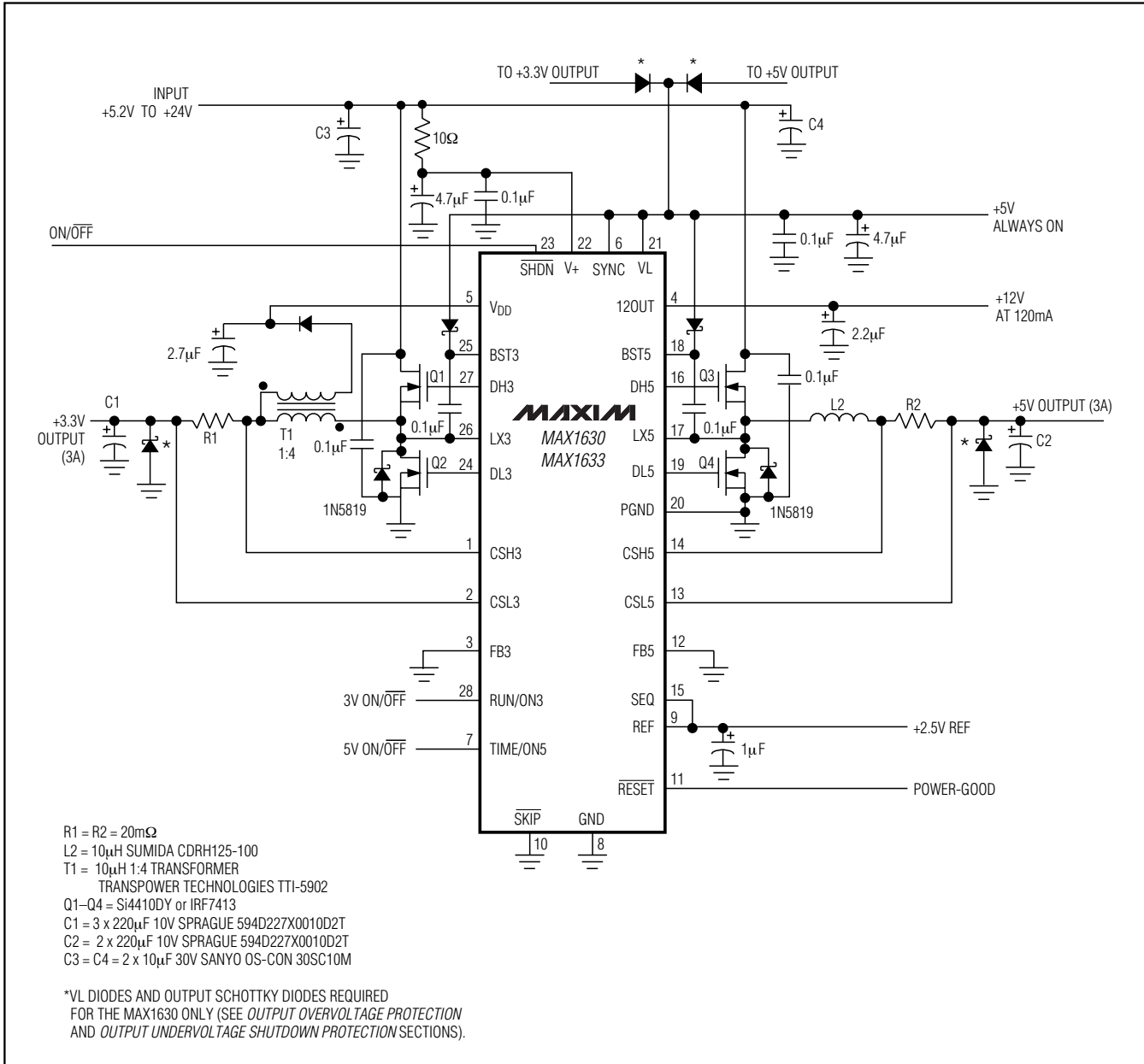

Figure 8. Triple-Output Application for Low-Voltage Batteries (MAX1630/MAX1633)



# Multi-Output, Low-Noise Power-Supply Controllers for Notebook Computers

## Application Circuits (continued)

MAX1630-MAX1635

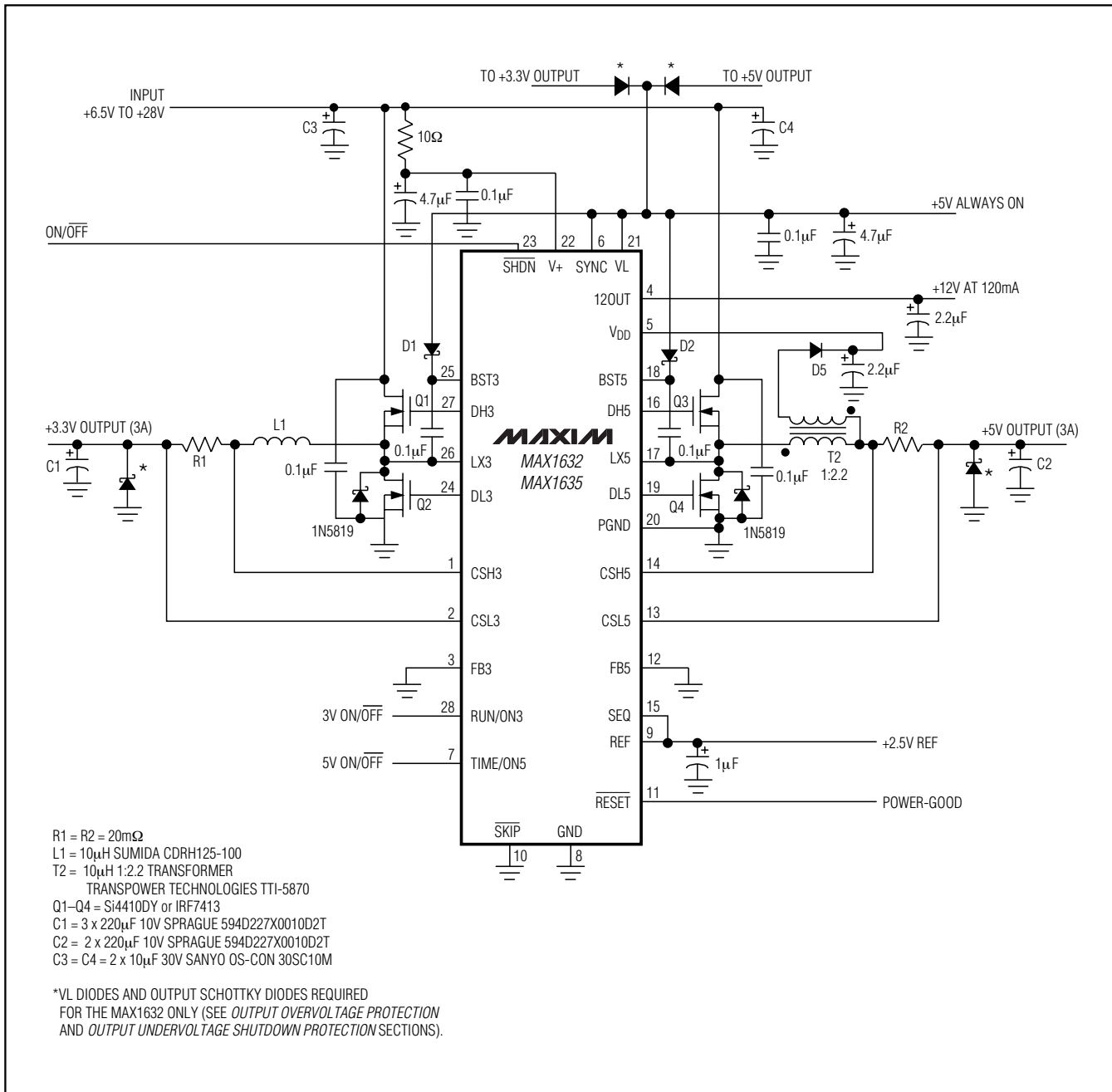

Figure 9. Triple-Output Application for High-Voltage Batteries (MAX1632/MAX1635)

# Multi-Output, Low-Noise Power-Supply Controllers for Notebook Computers

## Application Circuits (continued)

MAX1630-MAX1635

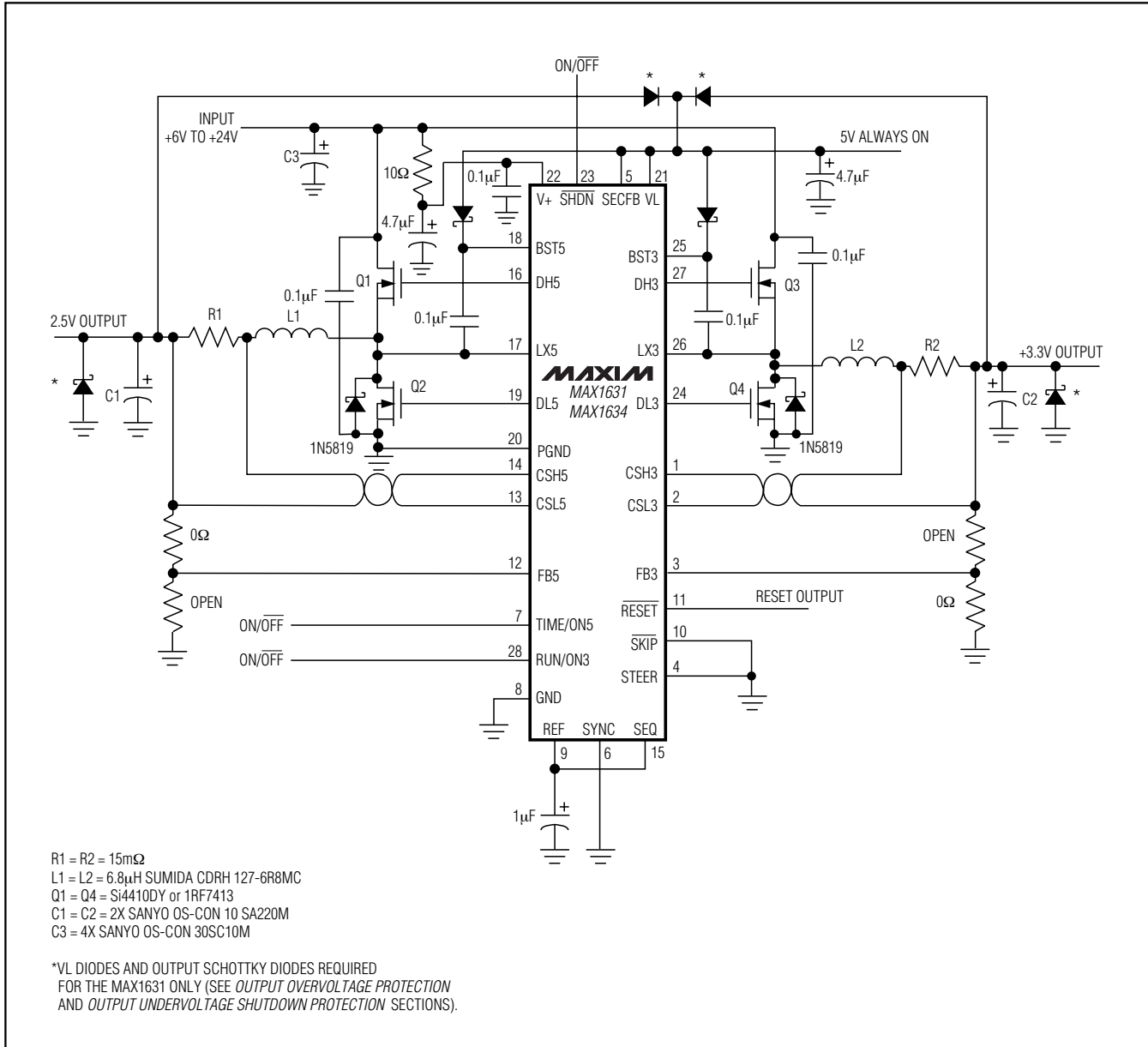
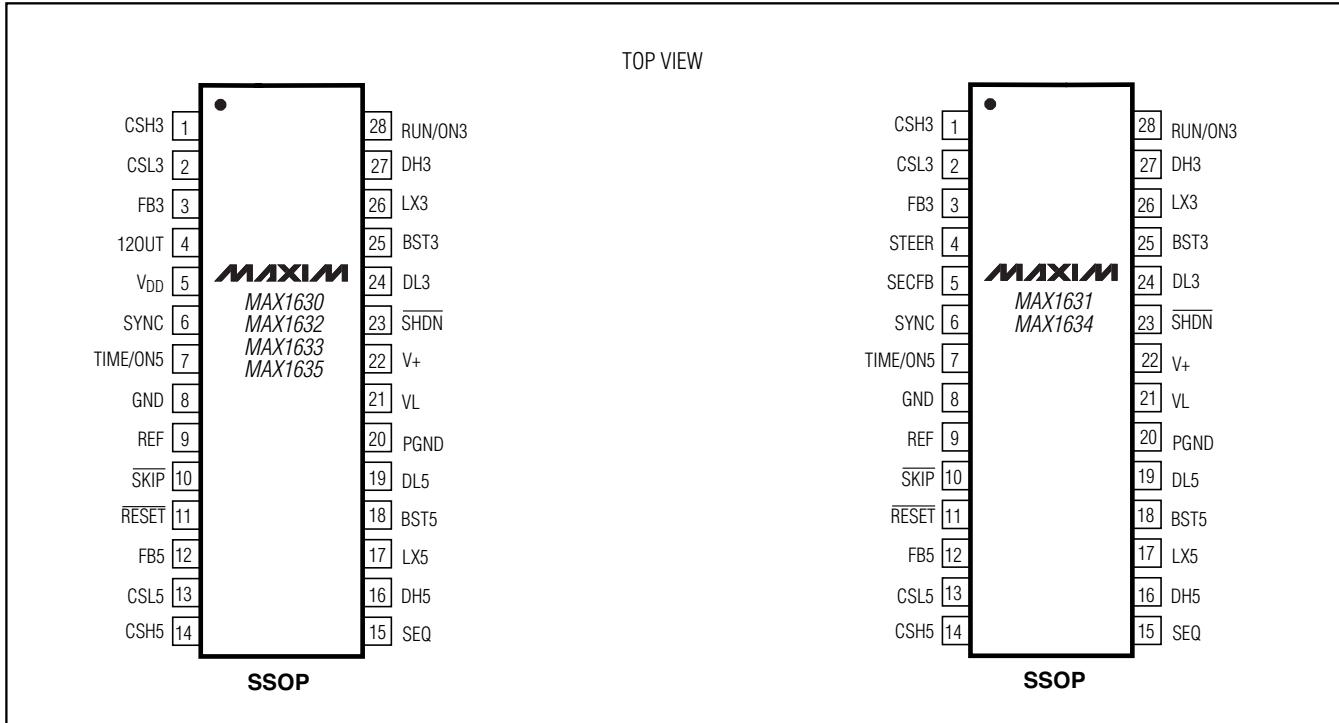

Figure 10. Dual, 4A, Notebook Computer Power Supply

# Multi-Output, Low-Noise Power-Supply Controllers for Notebook Computers

## Pin Configurations

**MAX1630-MAX1635**



## Selector Guide

DEVICE	AUXILIARY OUTPUT	SECONDARY FEEDBACK	OVER/UNDERVOLTAGE PROTECTION
MAX1630	12V Linear Regulator	Feeds into the 3.3V SMPS	Yes
MAX1631	None (SECFB input)	Selectable (STEER pin)	Yes
MAX1632	12V Linear Regulator	Feeds into the 5V SMPS	Yes
MAX1633	12V Linear Regulator	Feeds into the 3.3V SMPS	No
MAX1634	None (SECFB input)	Selectable (STEER pin)	No
MAX1635	12V Linear Regulator	Feeds into the 5V SMPS	No

# Multi-Output, Low-Noise Power-Supply Controllers for Notebook Computers

## Ordering Information (continued)

PART	TEMP RANGE	PIN-PACKAGE
<b>MAX1631</b> CAI	0°C to +70°C	28 SSOP
MAX1631CAI+	0°C to +70°C	28 SSOP
MAX1631EAI+	-40°C to +85°C	28 SSOP
<b>MAX1632</b> CAI	0°C to +70°C	28 SSOP
MAX1632CAI+	-40°C to +85°C	28 SSOP
MAX1632EAI+	-40°C to +85°C	28 SSOP
<b>MAX1633</b> CAI	0°C to +70°C	28 SSOP
MAX1633CAI+	0°C to +70°C	28 SSOP
MAX1633EAI+	-40°C to +85°C	28 SSOP
<b>MAX1634</b> CAI	0°C to +70°C	28 SSOP
MAX1634CAI+	0°C to +70°C	28 SSOP
MAX1634EAI+	-40°C to +85°C	28 SSOP
<b>MAX1635</b> CAI	0°C to +70°C	28 SSOP
MAX1635CAI+	0°C to +70°C	28 SSOP
MAX1635EAI+	-40°C to +85°C	28 SSOP

+ Denotes lead-free package.

# Multi-Output, Low-Noise Power-Supply Controllers for Notebook Computers

**MAX1630-MAX1635**

## Package Information

(The package drawing(s) in this data sheet may not reflect the most current specifications. For the latest package outline information go to [www.maxim-ic.com/packages](http://www.maxim-ic.com/packages).)

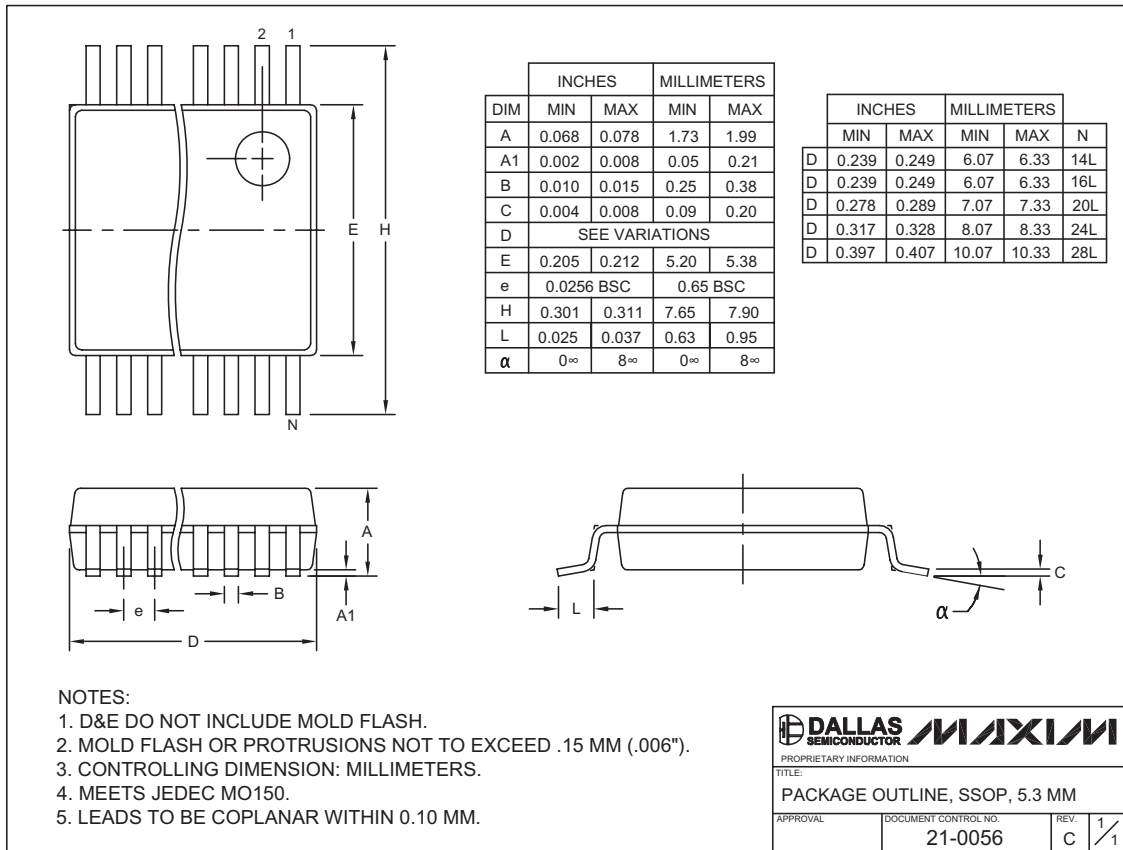

Maxim cannot assume responsibility for use of any circuitry other than circuitry entirely embodied in a Maxim product. No circuit patent licenses are implied. Maxim reserves the right to change the circuitry and specifications without notice at any time.

**Maxim Integrated Products, 120 San Gabriel Drive, Sunnyvale, CA 94086 408-737-7600** \_\_\_\_\_ **29**