

FEATURES

Input frequencies from 8 kHz to 710 MHz
Output frequencies up to 810 MHz
Preset pin-programmable frequency translation ratios cover popular wireline and wireless frequency applications, including xDSL, T1/E1, BITS, SONET, and Ethernet.
Arbitrary frequency translation ratios via SPI port
On-chip VCO
Accepts a crystal resonator for holdover applications
Two single-ended (or one differential) reference input(s)
Two output clocks (independently programmable as LVDS, LVPECL, or CMOS)
SPI-compatible, 3-wire programming interface
Single supply (3.3 V)
Very low power: <450 mW (under most conditions)
Small package size (5 mm × 5 mm)
Exceeds Telcordia GR-253 Category II OC-48 jitter generation, transfer, and tolerance specifications

APPLICATIONS

Cost effective replacement of high frequency VCXO, OCXO, and SAW resonators
Extremely flexible frequency translation for SONET/SDH, Gb Ethernet, Fibre Channel, DRFI/DOCSIS, and PON/EPON/GPON
Wireless infrastructure
Test and measurement (including handheld devices)

GENERAL DESCRIPTION

The AD9553 is a phase-locked loop (PLL) based clock translator designed to address the needs of passive optical networks (PON) and base stations. The device employs an integer-N PLL to accommodate the applicable frequency translation requirements. The user supplies up to two single-ended input reference signals or one differential input reference signal via the REFA and REFB inputs. The device supports holdover applications by allowing the user to connect a 25 MHz crystal resonator to the XTAL input. The device supports holdover applications by allowing the user to connect a 25 MHz crystal resonator to the XTAL input.

The AD9553 is pin programmable, providing a matrix of standard input/output frequency translations from a list of 15 possible input frequencies to a list of 51 possible output frequency pairs (OUT1 and OUT2). The device also has a 3-wire SPI interface, enabling the user to program custom input-to-output frequency translations.

The AD9553 output is compatible with LVPECL, LVDS, or single-ended CMOS logic levels, although the AD9553 is implemented in a strictly CMOS process.

The AD9553 operates over the extended industrial temperature range of -40°C to $+85^{\circ}\text{C}$.

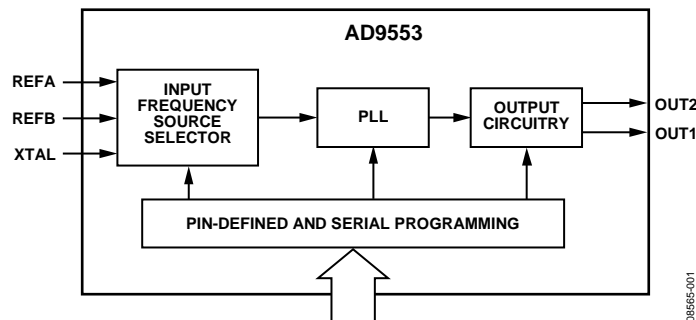
BASIC BLOCK DIAGRAM*Figure 1.***Rev. 0**

Information furnished by Analog Devices is believed to be accurate and reliable. However, no responsibility is assumed by Analog Devices for its use, nor for any infringements of patents or other rights of third parties that may result from its use. Specifications subject to change without notice. No license is granted by implication or otherwise under any patent or patent rights of Analog Devices. Trademarks and registered trademarks are the property of their respective owners.

TABLE OF CONTENTS

Features	1	Preset Frequencies	14
Applications	1	Device Control Modes	17
General Description	1	Theory of Operation	19
Basic Block Diagram	1	General Description	19
Revision History	2	Description of Functional Blocks	19
Specifications	3	Jitter Tolerance	25
Power Consumption	3	Output/Input Frequency Relationship	25
Logic Input Pins	3	Calculating Divider Values	26
Logic Output Pins	3	Low Dropout (LDO) Regulators	27
RESET Pin	4	Automatic Power-On Reset	27
Reference Clock Input Characteristics	4	Applications Information	28
VCO Characteristics	5	Thermal Performance	28
Crystal Input Characteristics	5	Serial Control Port	29
Output Characteristics	6	Serial Control Port Pin Descriptions	29
Jitter Characteristics	7	Operation of the Serial Control Port	29
Serial Control Port	8	Instruction Word (16 Bits)	30
Serial Control Port Timing	8	MSB/LSB First Transfers	30
Absolute Maximum Ratings	9	Register Map	32
ESD Caution	9	Register Map Descriptions	34
Pin Configuration and Function Descriptions	10	Outline Dimensions	41
Typical Performance Characteristics	11	Ordering Guide	41

REVISION HISTORY**4/10—Revision 0: Initial Version**

SPECIFICATIONS

POWER CONSUMPTION

Table 1.

Parameter	Min	Typ	Max	Unit	Test Conditions/Comments
TOTAL CURRENT		162	185	mA	Tested with both output channels active at maximum output frequency. LVPECL and LVDS outputs use a 100 Ω termination between both pins of the output driver.
VDD CURRENT BY PIN					Tested with both output channels active at maximum output frequency. LVPECL and LVDS outputs use a 100 Ω termination between both pins of the output driver.
Pin 18		93	106	mA	
Pin 21					
LVDS Configured Output		35	41	mA	
LVPECL Configured Output		36	42	mA	
CMOS Configured Output		29	34	mA	
Pin 28					
LVDS Configured Output		35	41	mA	
LVPECL Configured Output		36	42	mA	
CMOS Configured Output		29	34	mA	

LOGIC INPUT PINS

Table 2.

Parameter	Min	Typ	Max	Unit	Test Conditions/Comments
INPUT CHARACTERISTICS ¹					
Logic 1 Voltage, V_{IH}	1.02			V	For the CMOS inputs, a static Logic 1 results from either a pull-up resistor or no connection.
Logic 0 Voltage, V_{IL}			0.64	V	
Logic 1 Current, I_{IH}			3	μ A	
Logic 0 Current, I_{IL}			17	μ A	

¹ The A[3:0] and Y[5:0] pins have 100 k Ω internal pull-up resistors. The OM[2:0] pins have 40 k Ω pull-up resistors when the device is not in SPI mode.

LOGIC OUTPUT PINS

Table 3.

Parameter	Min	Typ	Max	Unit	Test Conditions/Comments
OUTPUT CHARACTERISTICS					
Output Voltage High, V_{OH}	2.7			V	Tested at 1 mA load current
Output Voltage Low, V_{OL}			0.19	V	Tested at 1 mA load current

AD9553

RESET PIN

Table 4.

Parameter	Min	Typ	Max	Unit	Test Conditions/Comments
INPUT CHARACTERISTICS ¹					
Input Voltage High, V _{IH}	1.96			V	
Input Voltage Low, V _{IL}			0.85	V	
Input Current High, I _{INH}		0.3	12.5	μA	
Input Current Low, I _{INL}		31	43	μA	
MINIMUM PULSE WIDTH LOW	150			μs	Tested with an active source driving the $\overline{\text{RESET}}$ pin.

¹The $\overline{\text{RESET}}$ pin has a 100 kΩ internal pull-up resistor.

REFERENCE CLOCK INPUT CHARACTERISTICS

Table 5.

Parameter	Min	Typ	Max	Unit	Test Conditions/Comments
DIFFERENTIAL INPUT					
Input Frequency Range	0.008		250 710	MHz MHz	Assumes minimum LVDS input level and requires bypassing of the /5 divider and 2× multiplier. Use ac coupling to preserve the internal dc bias of the differential input. Capacitive coupling required; can accommodate single-ended input by ac grounding unused input; the instantaneous voltage on either pin must not exceed the 3.3 V dc supply rails. Pulse width high and pulse width low establish the bounds for duty cycle. Up to 250 MHz. Up to 250 MHz. Beyond 250 MHz, up to 710 MHz. Beyond 250 MHz, up to 710 MHz.
Common-Mode Internally Generated Input Voltage	613	692	769	mV	
Differential Input Voltage Sensitivity	250			mV p-p	
Differential Input Resistance		5		kΩ	
Differential Input Capacitance		3		pF	
Duty Cycle					
Pulse Width Low	1.6			ns	
Pulse Width High	1.6			ns	
Pulse Width Low	0.64			ns	
Pulse Width High	0.64			ns	
CMOS SINGLE-ENDED INPUT					
Input Frequency Range	0.008		200	MHz	Pulse width high and pulse width low establish the bounds for duty cycle.
Input High Voltage ¹	1.05			V	
Input Low Voltage ¹			0.98	V	
Input High Current		0.04		μA	
Input Low Current		0.03		μA	
Input Capacitance		3		pF	
Duty Cycle					
Pulse Width Low	2			ns	
Pulse Width High	2			ns	
2× FREQUENCY MULTIPLIER			125	MHz	

¹The single-ended CMOS input is 3.3 V compatible. In the case of ac-coupling, the user must bias the input at 1.0 V dc.

VCO CHARACTERISTICS

Table 6.

Parameter	Min	Typ	Max	Unit	Test Conditions/Comments
FREQUENCY RANGE	3350		4050	MHz	
VCO GAIN		45		MHz/V	
VCO TRACKING RANGE	±300			ppm	
VCO CALIBRATION TIME					As measured from completion of the VCO calibration command (the rising edge of CS (Pin 12)) until the rising edge of LOCKED (Pin 20). Applies for A[3:0] = 0001 to 1100 or for A[3:0] = 1111.
Low BW Setting (170 Hz)					
13.3 kHz PFD Frequency		214		ms	
16 kHz PFD Frequency		176		ms	
High BW Setting (75 kHz)					Applies for A[3:0] = 1101 to 1110.
2.64 MHz PFD Frequency		1.46		ms	
4.86 MHz PFD Frequency		0.80		ms	
PLL LOCK TIME					Using the pin selected frequency settings. Lock time is from the rising edge of the RESET pin to the rising edge of the LOCKED pin. Applies for A[3:0] = 0001 to 1100 or for A[3:0] = 1111.
Low BW Setting (170 Hz)					
13.3 kHz PFD Frequency		214		ms	
16 kHz PFD Frequency		176		ms	
High BW Setting (75 kHz)					Applies for A[3:0] = 1101 to 1110.
2.64 MHz PFD Frequency		1.50		ms	
4.86 MHz PFD Frequency		0.89		ms	

CRYSTAL INPUT CHARACTERISTICS

Table 7.

Parameter	Min	Typ	Max	Unit	Test Conditions/Comments
CRYSTAL FREQUENCY					
Range	10	25	52	MHz	When using the pin selected frequency settings, the device requires a 25 MHz crystal to support holdover functionality.
Tolerance			20	ppm	
CRYSTAL MOTIONAL RESISTANCE			100	Ω	
CRYSTAL LOAD CAPACITANCE		10		pF	Using a crystal with a specified load capacitance other than 10 pF (8 pF to 24 pF) is possible, but necessitates using the SPI port.

AD9553

OUTPUT CHARACTERISTICS

Table 8.

Parameter	Min	Typ	Max	Unit	Test Conditions/Comments
LVPECL MODE					
Differential Output Voltage Swing	690	800	890	mV	Output driver static (for dynamic performance, see Figure 13).
Common-Mode Output Voltage	VDD – 1.66	VDD – 1.34	VDD – 1.01	V	Output driver static.
Frequency Range	0		810	MHz	
Duty Cycle	40		60	%	Up to 805 MHz output frequency.
Rise/Fall Time ¹ (20% to 80%)		255	305	ps	100 Ω termination between the output driver pins.
LVDS MODE					
Differential Output Voltage Swing					Output driver static (for dynamic performance, see Figure 13).
Balanced, V _{OD}	297		398	mV	Voltage swing between output pins; output driver static.
Unbalanced, ΔV _{OD}			8.3	mV	Absolute difference between voltage swing of normal pin and inverted pin; output driver static.
Offset Voltage					
Common Mode, V _{OS}	1.17		1.35	V	Output driver static.
Common-Mode Difference, ΔV _{OS}			7.3	mV	Voltage difference between output pins; output driver static.
Short-Circuit Output Current		17	24	mA	
Frequency Range	0		810	MHz	
Duty Cycle	40		60	%	Up to 805 MHz output frequency.
Rise/Fall Time ¹ (20% to 80%)		285	355	ps	100 Ω termination between the output driver pins.
CMOS MODE					
Output Voltage High, V _{OH}					Output driver static; standard drive strength setting.
I _{OH} = 10 mA	2.8			V	
I _{OH} = 1 mA	2.8			V	
Output Voltage Low, V _{OL}					Output driver static; standard drive strength setting.
I _{OL} = 10 mA			0.5	V	
I _{OL} = 1 mA			0.3	V	
Frequency Range	0		200	MHz	3.3 V CMOS; standard drive strength setting. Output toggle rates in excess of the maximum are possible, but with reduced amplitude (see Figure 12).
Duty Cycle	45		55	%	At maximum output frequency.
Rise/Fall Time ¹ (20% to 80%)		500	745	ps	3.3 V CMOS; standard drive strength setting; 10 pF load.

¹ The listed values are for the slower edge (rise or fall).

JITTER CHARACTERISTICS

Table 9.

Parameter	Min	Typ	Max	Unit	Test Conditions/Comments
JITTER GENERATION					
12 kHz to 20 MHz					
LVPECL Output		1.31		ps rms	Input = 122.88 MHz, output = 155.52 MHz.
LVDS Output		1.32		ps rms	Input = 122.88 MHz, output = 155.52 MHz.
CMOS Output		1.24		ps rms	Input = 122.88 MHz, output = 155.52 MHz.
LVPECL Output		1.28		ps rms	Input = 19.44 MHz, output = 245.76 MHz.
LVDS Output		1.29		ps rms	Input = 19.44 MHz, output = 245.76 MHz.
CMOS Output		1.26		ps rms	Input = 19.44 MHz, output = 245.76 MHz. See Figure 12 regarding CMOS toggle rates above 250 MHz.
50 kHz to 80 MHz					Input = 122.88 MHz, output = 155.52 MHz.
LVPECL Output		0.44		ps rms	Input = 122.88 MHz, output = 155.52 MHz.
LVDS Output		0.45		ps rms	Input = 122.88 MHz, output = 155.52 MHz.
CMOS Output		0.39		ps rms	Input = 122.88 MHz, output = 155.52 MHz.
LVPECL Output		0.75		ps rms	Input = 19.44 MHz, output = 245.76 MHz.
LVDS Output		0.76		ps rms	Input = 19.44 MHz, output = 245.76 MHz.
CMOS Output		0.44		ps rms	Input = 19.44 MHz, output = 245.76 MHz. See Figure 12 regarding CMOS toggle rates above 250 MHz.
JITTER TRANSFER BANDWIDTH					
Low BW Setting		170		Hz	See the Typical Performance Characteristics section. Applies to all input frequency pin programming configurations that use 170 Hz loop bandwidth per Table 17.
High BW Setting		75		kHz	Applies to all input frequency pin programming configurations that use 75 kHz loop bandwidth per Table 17.
JITTER TRANSFER PEAKING					
Low BW Setting		1.3		dB	See the Typical Performance Characteristics section Applies to all input frequency pin programming configurations that use 170 Hz loop bandwidth per Table 17.
High BW Setting		0.08		dB	Applies to all input frequency pin programming configurations that use 75 kHz loop bandwidth per Table 17.

AD9553

SERIAL CONTROL PORT

Table 10.

Parameter	Min	Typ	Max	Unit	Test Conditions/Comments
\overline{CS}					
Input Logic 1 Voltage	1.6			V	
Input Logic 0 Voltage			0.5	V	
Input Logic 1 Current			0.03	μA	
Input Logic 0 Current		2		μA	
Input Capacitance		2		pF	
SCLK					
Input Logic 1 Voltage	1.6			V	
Input Logic 0 Voltage			0.5	V	
Input Logic 1 Current		2		μA	
Input Logic 0 Current			0.03	μA	
Input Capacitance		2		pF	
SDIO					
Input					
Input Logic 1 Voltage	1.6			V	
Input Logic 0 Voltage			0.5	V	
Input Logic 1 Current		1		μA	
Input Logic 0 Current		1		μA	
Input Capacitance		2		pF	
Output					
Output Logic 1 Voltage	2.8			V	1 mA load current
Output Logic 0 Voltage			0.3	V	1 mA load current

SERIAL CONTROL PORT TIMING

Table 11.

Parameter	Limit	Unit
SCLK		
Clock Rate, $1/t_{CLK}$	50	MHz max
Pulse Width High, t_{HIGH}	3	ns min
Pulse Width Low, t_{LOW}	3	ns min
SDIO to SCLK Setup, t_{DS}	4	ns min
SCLK to SDIO Hold, t_{DH}	0	ns min
SCLK to Valid SDIO, t_{DV}	13	ns max
\overline{CS} to SCLK Setup (t_S) and Hold (t_H)	0	ns min
\overline{CS} Minimum Pulse Width High	6.4	ns min

ABSOLUTE MAXIMUM RATINGS

Table 12.

Parameter	Rating
Supply Voltage (VDD)	3.6 V
Maximum Digital Input Voltage	-0.5 V to VDD + 0.5 V
Storage Temperature Range	-65°C to +150°C
Operating Temperature Range	-40°C to +85°C
Lead Temperature (Soldering, 10 sec)	300°C
Junction Temperature	150°C

Stresses above those listed under Absolute Maximum Ratings may cause permanent damage to the device. This is a stress rating only; functional operation of the device at these or any other conditions above those indicated in the operational section of this specification is not implied. Exposure to absolute maximum rating conditions for extended periods may affect device reliability.

ESD CAUTION



ESD (electrostatic discharge) sensitive device. Charged devices and circuit boards can discharge without detection. Although this product features patented or proprietary protection circuitry, damage may occur on devices subjected to high energy ESD. Therefore, proper ESD precautions should be taken to avoid performance degradation or loss of functionality.

PIN CONFIGURATION AND FUNCTION DESCRIPTIONS

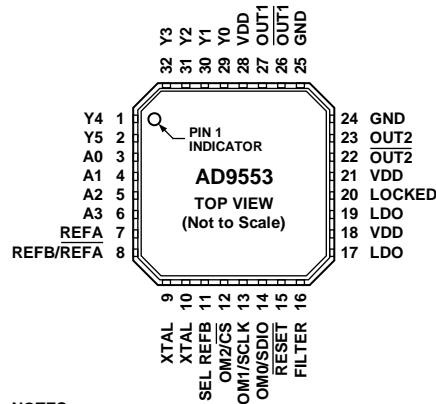

NOTES
1. EXPOSED DIE PAD MUST BE CONNECTED TO GND.

08565-002

Figure 2. Pin Configuration

Table 13. Pin Function Descriptions

Pin No.	Mnemonic	Type ¹	Description
29, 30, 31, 32, 1, 2	Y0, Y1, Y2, Y3, Y4, Y5	I	Control Pins. These pins select one of 51 preset output frequency combinations for OUT1 and OUT2. Note that when all six control pins are Logic 0, SPI programming is active.
3, 4, 5, 6	A0, A1, A2, A3	I	Control Pins. These pins select one of 15 preset input reference frequencies. Note that when all four control pins are Logic 0, SPI programming is active.
7	REFA	I	Reference Clock Input. Connect this pin to a single-ended active clock input signal. Alternatively, this pin is the noninverted part of a differential clock input signal.
8	REFB/ $\overline{\text{REFA}}$	I	Reference Clock Input. Connect this pin to a single-ended active clock input signal. Alternatively, this pin is the inverted part of a differential clock input signal.
9, 10	XTAL	I	Crystal Resonator Input. Connect a crystal resonator across these pins. When using the preset input/output frequencies via the Y[5:0] and A[3:0] pins, the crystal must have a resonant frequency of 25 MHz with a specified load capacitance of 10 pF.
11	SEL REFB	I	Control Pin. This pin allows manual selection of REFA (Logic 0) or REFB (Logic 1) as the active reference assuming that the desired reference signal is present. Note that this pin is nonfunctional when Register 0x29[5] = 1.
12	OM2/ $\overline{\text{CS}}$	I	Digital Input. When the device is not in SPI mode, this pin is an output mode control pin (OM2) with an internal 40 k Ω pull-up resistor. The OM2 pin, in conjunction with the OM0 and OM1 pins, allows the user to select 1-of-8 output configurations (see Table 21). In SPI mode, this pin is an active low chip select ($\overline{\text{CS}}$) with no internal pull-up resistor.
13	OM1/SCLK	I	Digital Input. When the device is not in SPI mode, this pin is an output mode control pin (OM1) with an internal 40 k Ω pull-up resistor. The OM1 pin, in conjunction with the OM0 and OM2 pins, allows the user to select 1-of-8 output configurations (see Table 21). In SPI mode, this pin is the serial data clock (SCLK) with no internal pull-up resistor.
14	OM0/SDIO	I/O	Digital Input/Output. When the device is not in SPI mode, this pin is an input only and functions as an output mode control pin (OM0) with an internal 40 k Ω pull-up resistor. The OM0 pin, in conjunction with the OM1 and OM2 pins, allows the user to select 1-of-8 output configurations (see Table 21). In SPI mode, this pin is the serial data input/output (SDIO) with no internal pull-up resistor.
15	$\overline{\text{RESET}}$	I	Digital Input, Active Low with a 100 k Ω Internal Pull-Up Resistor. Resets the internal logic to default states (see the Automatic Power-On Reset section).
16	FILTER	I/O	Loop Filter Node for the PLL. Connect external loop filter components (see Figure 22) from this pin to Pin 17 (LDO).
17, 19	LDO	P/O	LDO Decoupling Pins. Connect a 0.47 μF decoupling capacitor from each of these pins to ground.
18, 21, 28	VDD	P	Power Supply Connection: 3.3 V Analog Supply.
20	LOCKED	O	Active High Locked Status Indicator for the PLL.
26, 22	$\overline{\text{OUT1}}$, $\overline{\text{OUT2}}$	O	Complementary Square Wave Clocking Outputs.
27, 23	OUT1, OUT2	O	Square Wave Clocking Outputs.
24, 25	GND	P	Ground.
EP	Exposed die pad		The exposed die pad must be connected to GND.

¹ I = input, I/O = input/output, O = output, P = power, and P/O = power/output.

TYPICAL PERFORMANCE CHARACTERISTICS

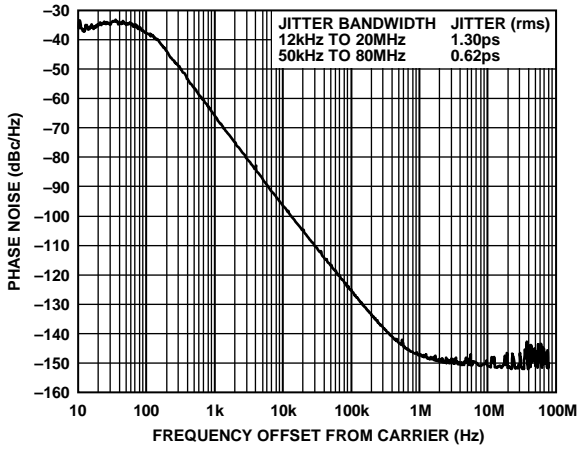

Figure 3. Phase Noise, Pin Programmed
($f_{XTAL} = 25 \text{ MHz}$, $f_{OUT1} = 156.25 \text{ MHz}$)

08565-203

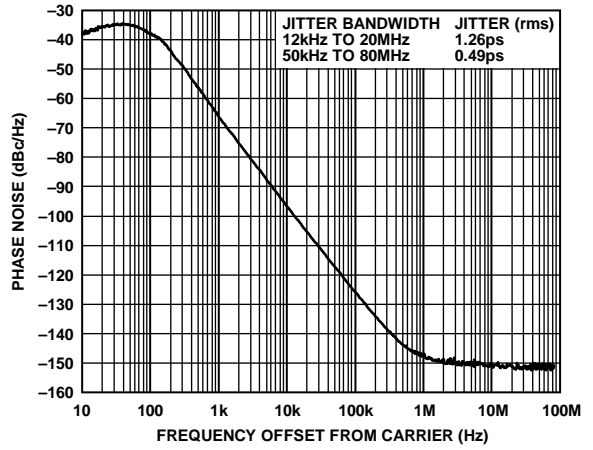

Figure 6. Phase Noise, Pin Programmed
($f_{REF} = 19.44 \text{ MHz}$, $f_{OUT1} = 155.52 \text{ MHz}$)

08565-206

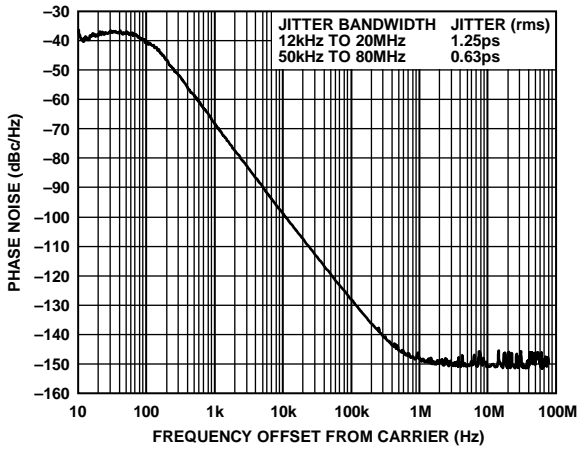

Figure 4. Phase Noise, Pin Programmed
($f_{REF} = 61.44 \text{ MHz}$, $f_{OUT1} = 122.88 \text{ MHz}$)

08565-204

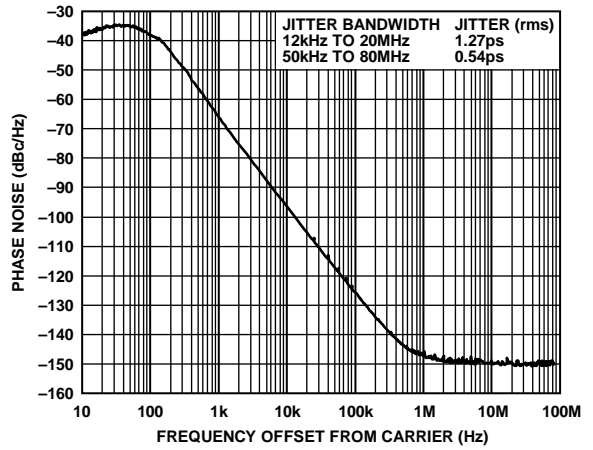

Figure 7. Phase Noise, Pin Programmed
($f_{REF} = 8 \text{ kHz}$, $f_{OUT1} = 155.52 \text{ MHz}$)

08565-207

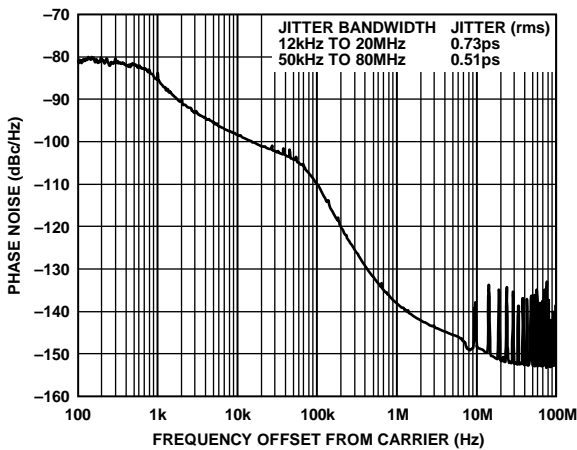

Figure 5. Phase Noise, Pin Programmed
($f_{REF} = 77.76 \text{ MHz}$, $f_{OUT1} = 622.08 \text{ MHz}$)

08565-205

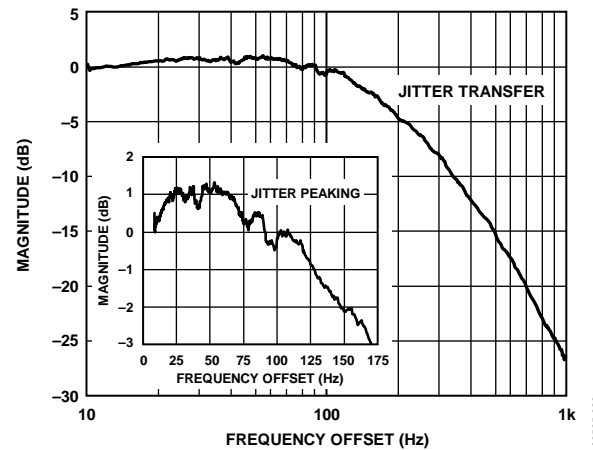

Figure 8. Jitter Transfer, Loop Bandwidth = 170 Hz

08565-028

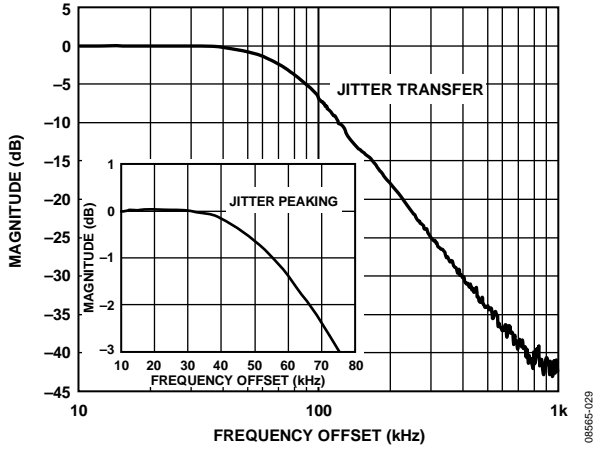

Figure 9. Jitter Transfer, Loop Bandwidth = 75 kHz

08565-029

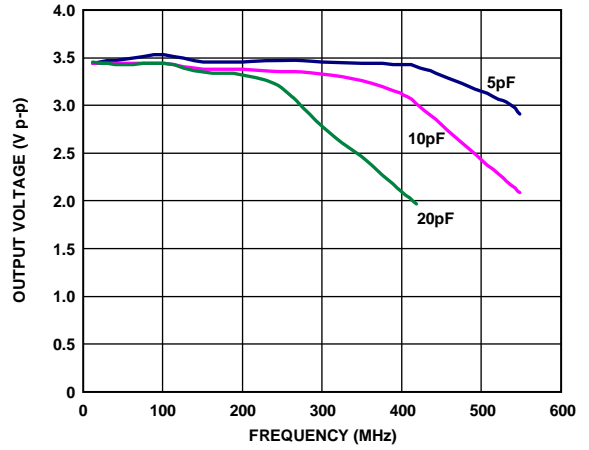

Figure 12. Peak-to-Peak Output Voltage vs. Frequency, CMOS

08565-211

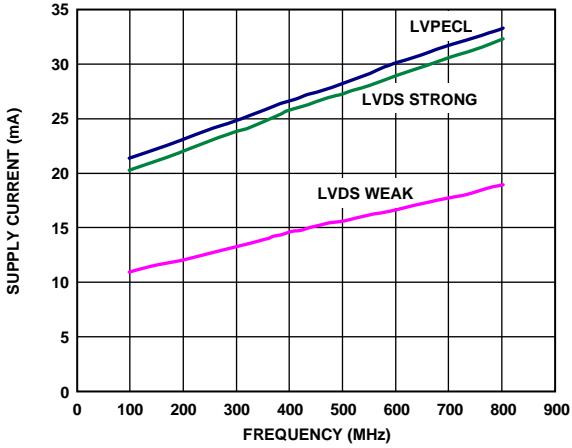

Figure 10. Supply Current vs. Output Frequency, LVPECL and LVDS (10 pF Load)

08565-209

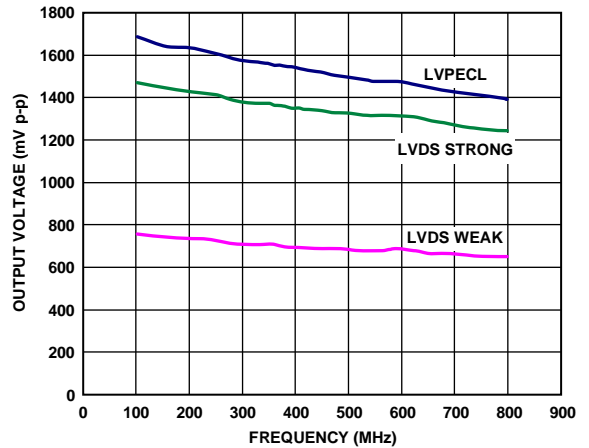

Figure 13. Peak-to-Peak Output Voltage vs. Frequency, LVPECL and LVDS (100 Ω Load)

08565-212

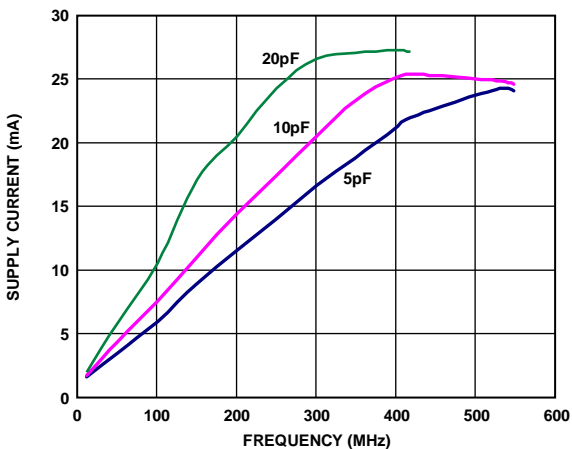

Figure 11. Supply Current vs. Output Frequency, CMOS (10 pF Load)

08565-210

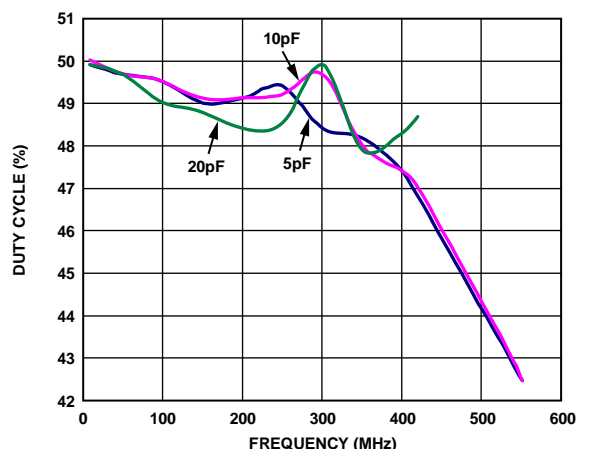

Figure 14. Duty Cycle vs. Output Frequency, CMOS

08565-213

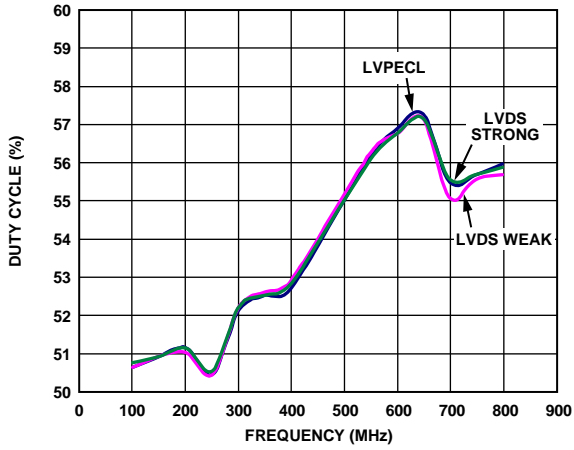

Figure 15. Duty Cycle vs. Output Frequency, LVPECL and LVDS (100 Ω Load)

08965-214

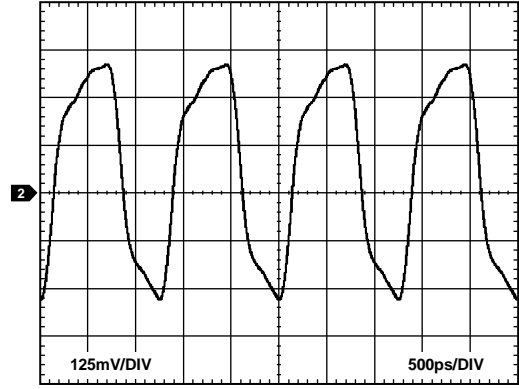

Figure 17. Typical Output Waveform, LVDS (800 MHz, 3.5 mA Drive Current)

08965-216

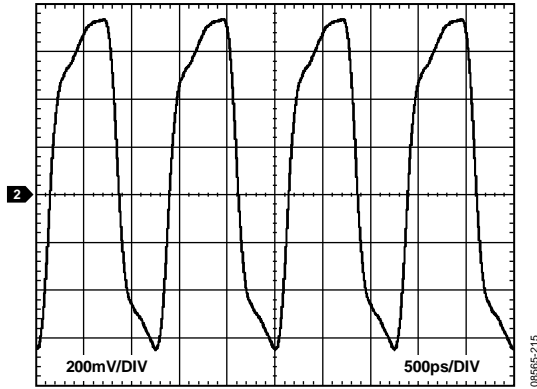

Figure 16. Typical Output Waveform, LVPECL (800 MHz)

08965-215

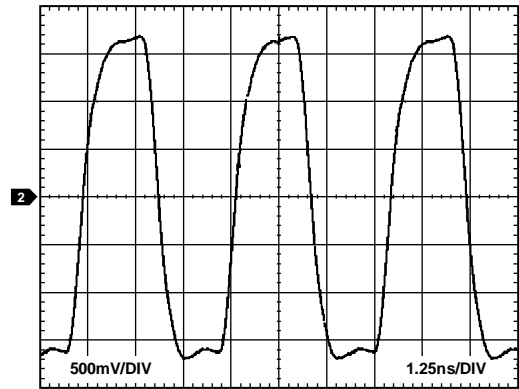

Figure 18. Typical Output Waveform, CMOS (250 MHz, 10 pF Load)

08965-217

PRESET FREQUENCIES

The frequency selection pins (A[3:0] and Y[5:0]) allow the user to hardwire the device for preset input and output frequencies based on the pin logic states (see Figure 20). The pins decode ground or open connections as Logic 0 or Logic 1, respectively.

In order to have access to the device control registers via the SPI port, the user must select Y[5:0] = 000000 and/or A[3:0] = 0000. Doing so causes Pin 12 through Pin 14 to function as SPI port control pins instead of output mode control pins (see the Output Driver Mode Control section). Note that after selecting SPI mode, the user must write a Logic 1 to Bit 0 of Register 0x32 and Register 0x34 to enable the registers as the source of the OUT1 and OUT2 mode control bits (see Figure 23 and the Output Driver Mode Control section).

The A[3:0] pins allow the user to select one of fifteen input reference frequencies as shown in Table 14. The device sets the appropriate divide-by-5 ($/5_A$, $/5_B$), multiply-by-2 ($\times 2_A$, $\times 2_B$), and input divider (R_A , R_B , R_{XO}) values based on the logic levels applied to the A[3:0] pins.

The same settings apply to both the REFA and REFB input paths. Furthermore, the $/5$, $\times 2$, and R values cause the PLL input frequency to be either 16 kHz or 40/3 kHz. The exceptions are A[3:0] = 1101 and 1110, which yield a PLL input frequency of 155.52/59 MHz and 4.86 MHz, respectively. Note that the XTAL input is not available for holdover functionality in the A[3:0] = 1101 and 1110 configurations, thus the undefined R_{XO} value.

The Y[5:0] pins allow the user to select one of 51 output frequency combinations (f_{OUT1} and f_{OUT2}) per Table 15. The device sets the appropriate P_0 , P_1 , and P_2 settings based on the logic levels applied to the Y[5:0] pins. Note, however, that selections 101101 through 110010 require A[3:0] = 1101 and selection 110011 requires A[3:0] = 1110.

The value (N) of the PLL feedback divider and the control setting for the charge pump current (CP) depend on a combination of both the A[3:0] and Y[5:0] pin settings as shown in Table 16.

Table 14. Pin-Configured Input Frequency¹

Pins A[3:0]	f_{REFA} , f_{REFB} (MHz)	$/5_A$, $/5_B$	$\times 2_A$, $\times 2_B$	R_A , R_B (Decimal)	R_{XO} (Decimal)
0000	SPI mode				
0001	0.008	–	On	1	3125
0010	1.536	–	–	96	3125
0011	2.048	–	–	128	3125
0100	16.384	–	–	1024	3125
0101	19.44	–	–	1215	3125
0110	25	–	On	3125	3125
0111	38.88	–	–	2430	3125
1000	61.44	–	–	3840	3125
1001	77.76	–	–	4860	3125
1010	122.88	–	–	7680	3125
1011	125	On	On	3125	3125
1100	1.544	–	On	193	3125
1101 ²	155.52	–	–	59	Undefined
1110 ³	77.76	–	–	16	Undefined
1111	200/3	–	–	5000	3750

¹ For $/5$ and $\times 2$ frequency scalars, – indicates bypassed and On indicates active.

² Pins A[3:0] = 1101 only works with Pins Y[5:0] = 101101 through 110010.

³ Pins A[3:0] = 1110 only works with Pins Y[5:0] = 110011.

Table 15. Pin-Configured Output Frequency

Pins Y[5:0]	f _{OUT1} (MHz)	f _{OUT2} (MHz)	P ₀	P ₁	P ₂
000000	SPI mode				
000001	245.76	245.76	5	3	3
000010	245.76	122.88	5	3	6
000011	245.76	61.44	5	3	12
000100	245.76	16.384	5	3	45
000101	245.76	2.048	5	3	360
000110	245.76	1.536	5	3	480
000111	122.88	122.88	5	6	6
001000	122.88	61.44	5	6	12
001001	122.88	16.384	5	6	45
001010	122.88	2.048	5	6	360
001011	122.88	1.536	5	6	480
001100	61.44	61.44	5	12	12
001101	61.44	16.384	5	12	45
001110	61.44	2.048	5	12	360
001111	61.44	1.536	5	12	480
010000	16.384	16.384	5	45	45
010001	16.384	2.048	5	45	360
010010	16.384	1.536	5	45	480
010011	2.048	2.048	5	360	360
010100	2.048	1.536	5	360	480
010101	1.536	1.536	5	480	480
010110	156.25	156.25	6	4	4
010111	156.25	125	6	4	5
011000	156.25	25	6	4	25
011001	125	125	6	5	5
011010	125	25	6	5	25
011011	25	25	6	25	25
011100	155.52	155.52	6	4	4
011101	155.52	77.76	6	4	8
011110	155.52	19.44	6	4	32
011111	77.76	77.76	6	8	8
100000	77.76	19.44	6	8	32
100001	19.44	19.44	6	32	32
100010	153.6	153.6	6	4	4
100011	153.6	122.88	6	4	5
100100	153.6	61.44	6	4	10
100101	153.6	2.048	6	4	300
100110	153.6	1.536	6	4	400
100111	100	100	6	6	6
101000	100	50	6	6	12
101001	100	25	6	6	24
101010	50	50	6	12	12
101011	50	25	6	12	24
101100	1.544	1.544	6	400	400
101101	Fo ¹	Fo ¹	6	1	1
101110	Fo ¹	Fo/2 ¹	6	1	2
101111	Fo ¹	Fo/4 ¹	6	1	4
110000	Fo/2 ¹	Fo/2 ¹	6	2	2
110001	Fo/2 ¹	Fo/4 ¹	6	2	4
110010	Fo/4 ¹	Fo/4 ¹	6	4	4
110011	622.08	622.08	6	1	1
110100 to 111111	Undefined	Undefined	Undefined	Undefined	Undefined

¹ Fo = 39,191.04/59 MHz.

AD9553

Table 16. Pin Configuration vs. N¹ and CP²

Pins A[3:0]	Pins Y[5:0]	N	CP
0001 to 1100	000001 to 010101	230,400	121
	010110 to 011011	234,375	121
	011100 to 100001	233,280	121
	100010 to 100110	230,400	121
	100111 to 101011	225,000	121
	101100	231,600	121
	101101 to 111111	Undefined	Undefined
1101	000001 to 101100	Undefined	Undefined
	101101 to 110010	1512	255
	110010 to 111111	Undefined	Undefined
1110	000001 to 110010	Undefined	Undefined
	110011	768	121
	110100 to 111111	Undefined	Undefined
1111	000001 to 010101	276,480	145
	010110 to 011011	281,250	145
	011100 to 100001	279,936	145
	100010 to 100110	276,480	145
	100111 to 101011	270,000	145
	101100	277,920	145
	101101 to 111111	Undefined	Undefined

¹ PLL feedback divider value (decimal).

² Charge pump register value (decimal).

DEVICE CONTROL MODES

The AD9553 provides two modes of control: pin control and register control. Pin control, via the frequency selection pins (A[3:0] and Y[5:0]) as described in the Preset Frequencies section, is the simplest. Typically, pin control is for applications requiring only a single set of operating parameters (assuming that one of the options available via the frequency selection pins provides the parameters that satisfy the application requirements). Register control is typically for applications that require the flexibility to program different operating parameters

from time to time, or for applications that require parameters not available with any of the pin control options. The block diagram (see Figure 19) shows how the SPI and pin control modes interact.

The SPI/OM[2:0] label in Figure 19 refers to Pin 12, Pin 13, and Pin 14 of the AD9553. Furthermore, the SPI mode signal is Logic 1 when A[3:0] = 0000 and/or Y[5:0] = 000000; otherwise, it is Logic 0.

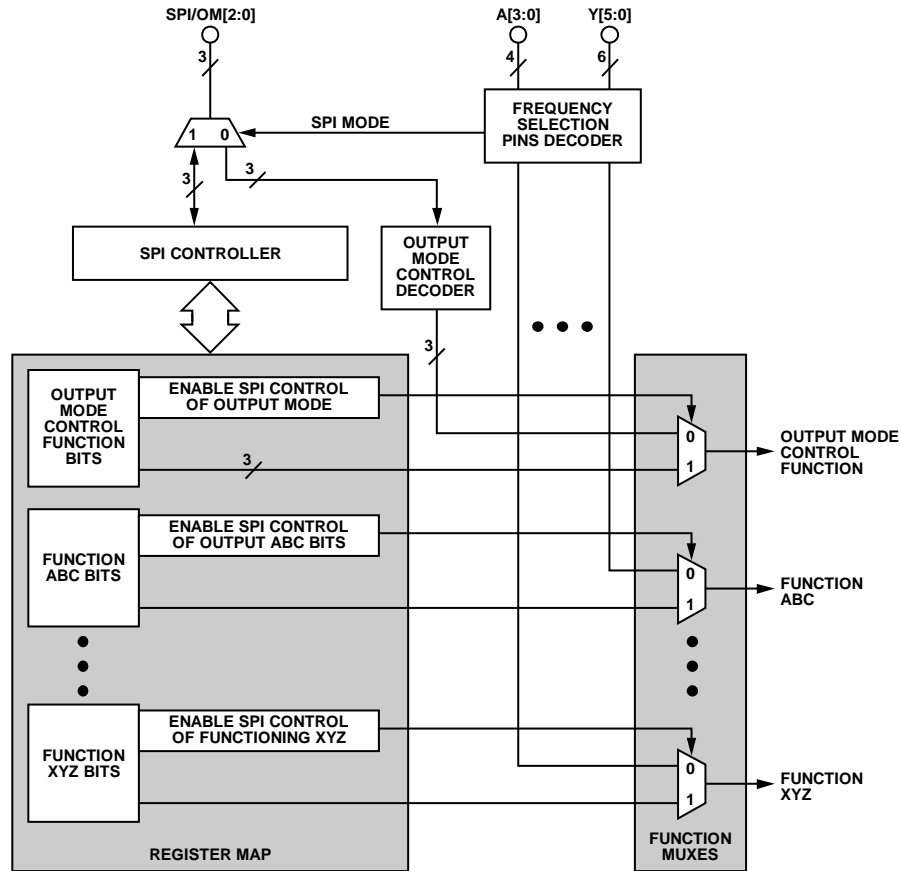

Figure 19. Control Mode Diagram

The SPI/OM[2:0] pins serve double duty (as either SPI pins or output mode control pins). A mux (controlled by the SPI mode signal) selects whether the three signals associated with the SPI/OM[2:0] pins connect to the output mode control decoder or to the SPI controller. Note that the SPI mode signal originates from the frequency selection pins decoder.

To enable communication with the SPI controller (SPI mode), the user must apply the appropriate logic pattern to the frequency selection pins ($A[3:0] = 0000$ and/or $Y[5:0] = 000000$). Note that as long as the frequency selection pins are set to invoke SPI mode, the user cannot establish output mode control via the output mode control decoder. Conversely, when the frequency selection pins are set to anything other than SPI mode, the user cannot communicate with the device via the SPI controller.

In Figure 19, note that some of the functions internal to the AD9553 are controlled by function bits that originate either from the two pin decoders or from within the register map. Specifically, each function receives its function bits from a function mux; and each function mux, in turn, receives its control signal from a single enable SPI control bit in the register map.

Be aware that the default values within the register map are such that all enable SPI control bits are Logic 0. Thus, the default state of the device is such that each function mux selects the pin decoders (not the register map) as the source for all control functions.

In order to switch a function mux so that it selects function bits from the register map, the user must first set the frequency selection pins to SPI mode. Then, write a Logic 1 to the appropriate enable SPI control bit in the register map. Be aware that the function mux routes the function bits in the register map

to the selected function the instant that the enable SPI control bit becomes Logic 1. Thus, it is a good idea to program the function bits to the desired state prior to writing Logic 1 to the corresponding enable SPI control bit.

Although the SPI and pin control modes are functionally independent, it is possible to mix the control modes. For example, suppose that pin control satisfies all of the requirements for an application except for the value of the P_2 divider (which is associated with OUT2). The user could do the following:

- Activate SPI mode via the frequency selection pins.
- Program the desired P_0 , P_1 , and P_2 values in the register map (Register 0x15 to Register 0x18).
- Set the enable SPI control bit for the output dividers (Register 0x14[2] = 1).
- Calibrate the VCO by enabling SPI control of VCO calibration (Register 0x0E[2] = 1), then issue a calibrate command (Register 0x0E[7] = 1). Be sure to program the N divider, R dividers, /5 dividers, and $\times 2$ multipliers to the values defined by the $A[3:0]$ and $Y[5:0]$ pin settings prior to calibrating the VCO.
- Restore the original settings to the frequency selection pins to invoke the desired frequency selection.

In this way, the function muxes that control P_0 , P_1 , and P_2 select the appropriate register bits as the source for controlling the dividers, while all the other function muxes select the pin decoders as the source for controlling the other functions. Note that the dividers remain under register control until the user activates SPI mode and writes Register 0x14[2] = 0, thereby causing the function mux to use the frequency selection pins decoder as the source for controlling the dividers, instead of the register map.

THEORY OF OPERATION

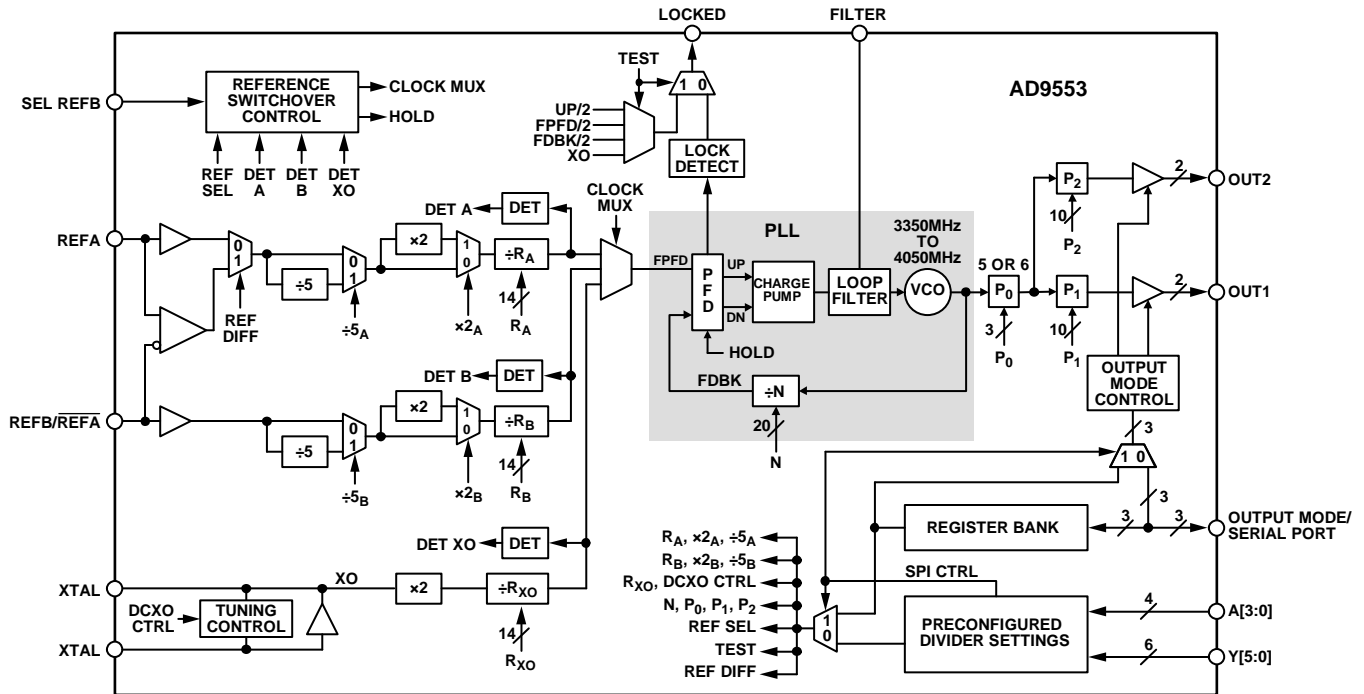

Figure 20. Detailed Block Diagram

GENERAL DESCRIPTION

The AD9553 can receive up to two input reference clocks, REFA and REFB. Both input clock paths include an optional divide-by-5 (/5) prescaler, an optional 2× frequency multiplier, and a 14-bit programmable divider. Alternatively, the user can program the device to operate with one differential input clock (instead of two single-ended input clocks) via the serial I/O port. In the differential operating mode, the REFB path is inactive.

The AD9553 also has a dedicated XTAL input for direct connection of an optional 25 MHz crystal resonator. This allows for a backup clock signal useful for holdover operation in case both input references fail. The XTAL clock path includes a fixed 2× frequency multiplier and a 14-bit programmable divider.

The AD9553 includes a switchover control block that automatically handles switching from REFA to REFB (or vice versa) in the event of a reference failure. If both REFA and REFB fail, however, then the switchover control block automatically enters holdover mode by selecting the XTAL clock signal (assuming the presence of a crystal resonator at the XTAL input).

Generally, the clock signals that appear at the input to the clock multiplexer (see Figure 20) all operate at the same frequency. Thus, the frequency at the input to the PLL (FPFD in Figure 20) is the same regardless of the signal selected by the clock multiplexer. The PLL converts FPFD to a frequency within the operating range of the VCO (3.35 GHz to 4.05 GHz) based on the value of the feedback divider (N). The VCO prescaler (P₀) reduces the VCO output frequency by a factor of either 5 or 6,

resulting in an intermediate frequency in the range of 558 MHz to 810 MHz. The 10-bit P₁ and P₂ dividers can further reduce the P₀ output frequency to yield the final output clock frequencies at OUT1 and OUT2, respectively.

Thus, the frequency translation ratio from the reference input to the output depends on the selection of the /5 prescalers; the 2× frequency multipliers; the values of the three R dividers; the N divider; and the P₀, P₁, and P₂ dividers. The user can set all of these parameters automatically by using the preconfigured divider settings available via the A[3:0] and Y[5:0] pins (see the Preset Frequencies section). Alternatively, the user can custom program these parameters via the serial I/O port (see the Serial Control Port and Register Map sections), allowing the device to accommodate custom frequency translation ratios.

DESCRIPTION OF FUNCTIONAL BLOCKS

Reference Inputs

The default configuration of the AD9553 provides up to two single-ended input clock receivers, REFA and REFB, which are high impedance CMOS inputs. In applications that require redundant reference clocks with switchover capability, REFA is the primary reference and REFB the secondary reference. Alternatively, the user can configure the input (via the serial I/O port) as a single differential receiver. In this case, the REFB input functions as REFA (the complementary input of REFA). Note that in this configuration the device operates with only one reference input clock, eliminating the need for switchover functionality.

XTAL Input

The AD9553 accepts an optional 25 MHz crystal resonator connected across the XTAL pins. Unless otherwise programmed, the device expects the crystal to have a specified load capacitance of 10 pF (default). The AD9553 provides the necessary load capacitance internally. The internal load capacitance consists of a fixed component of 8 pF and a variable (programmable) component of 0 pF to 15.75 pF.

After applying power to the AD9553 (or after a device reset), the programmable component defaults to 2 pF. This establishes the default load capacitance of 10 pF (8 pF fixed plus 2 pF programmable).

To accommodate crystals with a specified load capacitance other than 10 pF (8 pF to 23.75 pF), the user can adjust the programmable capacitance in 0.25 pF increments via Register 0x1B[5:0]. Note that when the user sets Register 0x1B[7] to 0 (enabling SPI control of the XTAL tuning capacitors), the variable capacitance changes from 2 pF (its default power-up value) to 15.75 pF due to the default value of Register 0x1B[5:0]. This causes the crystal load capacitance to be 23.75 pF until the user overwrites the default contents of Register 0x1B[5:0].

A noncomprehensive, alphabetical list of crystal manufacturers includes the following:

- AVX/Kyocera
- ECS
- Epson Toyocom
- Fox Electronics
- NDK
- Siward

Although these crystals meet the load capacitance and motional resistance requirements of the AD9553 according to their data sheets, Analog Devices, Inc., does not guarantee their operation with the AD9553, nor does Analog Devices endorse one supplier of crystals over another.

Input Frequency Prescalers ($/5_A$, $/5_B$)

The $/5$ prescalers provide the option to reduce the input reference frequency by a factor of five. Note that the prescalers physically precede the $2\times$ frequency multipliers. This allows the prescalers to bring a high frequency reference clock down to a frequency that is within the range of the $2\times$ frequency multipliers.

Input $2\times$ Frequency Multipliers ($\times 2_A$, $\times 2_B$)

The $2\times$ frequency multipliers provide the option to double the frequency at their input. This allows the user to take advantage of a higher frequency at the input to the PLL (FPFD), which allows for greater separation between the frequency generated by the PLL and the modulation spur associated with FPFD. However, increased reference spur separation comes at the expense of the harmonic spurs introduced by the frequency

multiplier. As such, beneficial use of the frequency multiplier is application specific. Note that the maximum input frequency to the $2\times$ frequency multipliers must not exceed 125 MHz.

Input Clock Detectors

The three clock input sections (REFA, REFB, and XTAL) include a dedicated monitor circuit that detects signal presence at the input. The detectors provide input to the switchover control block to support automatic reference switching and holdover operation.

Switchover/Holdover

The AD9553 supports automatic reference switching and holdover functions. It also supports manual reference switching via an external pin (SEL REFB) or via program control using the serial I/O port. A block diagram of the switchover/holdover capability appears in Figure 21. Note that the mux selects one of the three input signals (REFA, REFB, or XTAL) routing it to the input of the PLL. The selection of an input signal depends on which signals are present along with the contents of Register 0x29[7:6] and the logic level at the SEL REFB pin.

Note that each input signal has a dedicated signal presence detector. Each detector uses the feedback signal from the PLL as a sampling clock (which is always present due to the free-running VCO). This allows the detectors to determine the presence or absence of the input signals reliably. Note that the mux control logic uses the detector signals directly in order to determine the need for a switch to holdover operation.

Holdover occurs whenever the mux control logic determines that both the REFA and REFB signals are not present, in which case the device selects the XTAL signal if it is present. The exception is when Register 0x29[7:6] = 10 or 11, which disables the holdover function. If none of the three input signals is present, the device waits until at least one signal becomes present and selects according to the device settings (Register 0x29[7:6] and the logic level at the SEL REFB pin).

When the device is reset (or following a power-up), the internal logic defaults to revertive switchover mode (Register 0x29[7:6] = 00). In revertive switchover mode, the device selects the REFA signal whenever it is present. If REFA is not present, then the device selects the REFB signal, if present, but returns to REFA whenever it becomes available. That is, in revertive switchover mode, the device favors REFA. If both REFA and REFB are not present, the device switches to holdover mode.

When programmed for nonrevertive switchover mode (Register 0x29[7:6] = 01), the device selects the REFA signal if it is present. If REFA is not present, then the device selects the REFB signal (if present). Even if REFA becomes available, the device continues to use REFB until REFB fails. That is, in nonrevertive switchover mode, the switch to REFB is permanent unless REFB fails (or unless both REFA and REFB fail, in which case the device switches to holdover mode).

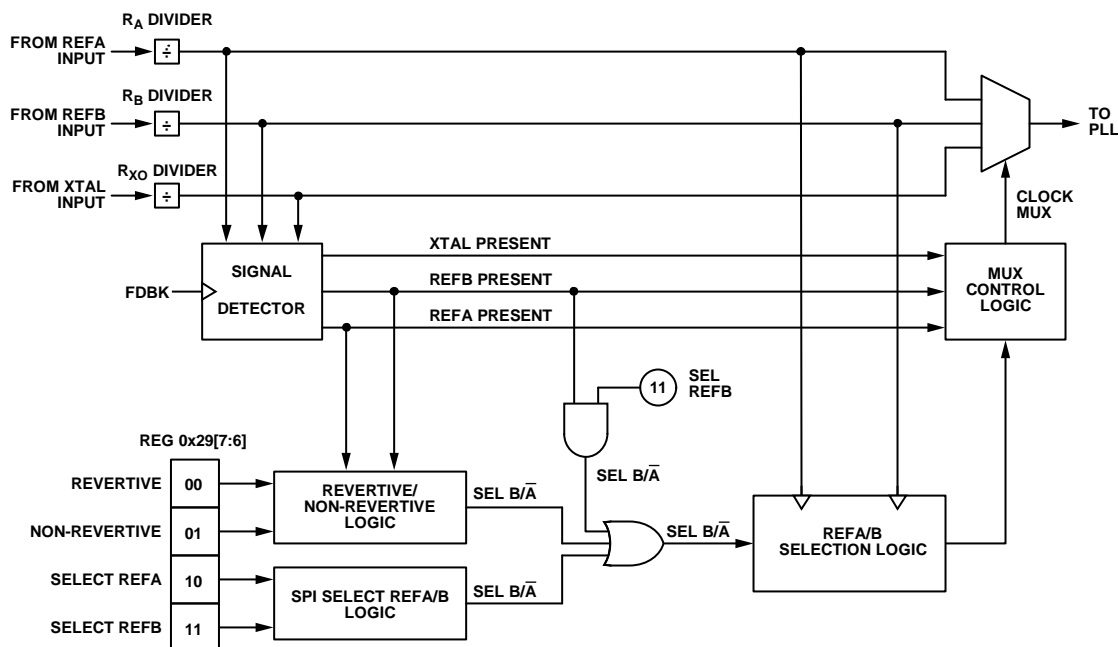

Figure 21. Switchover/Holdover Block Diagram

08665-102

The user can override the automatic switchover functions (revertive and nonrevertive) and manually select the REFA or REFB signal by programming Register 0x29[7:6] = 10 or 11, respectively. Note, however, that the desired signal (REFA or REFB) must be present for the device to select it.

The user can also force the device to switch to REFB by applying a Logic 1 to the external SEL REFB pin. This overrides a REFA selection invoked by either the revertive/nonrevertive logic or when Register 0x29[7:6] = 10. Note, however, that REFB must be present to be selected by the device.

PLL (PFD, Charge Pump, VCO, Feedback Divider)

The PLL (see Figure 20) consists of a phase-frequency detector (PFD), a partially integrated analog loop filter (see Figure 22), an integrated voltage-controlled oscillator (VCO), and a 20-bit programmable feedback divider. The PLL generates a 3.35 GHz to 4.05 GHz clock signal based on the frequency of PFD (see Figure 20) and the feedback divider value, which is phase-locked to the input reference signal.

The PFD of the PLL drives a charge pump that increases, decreases, or holds constant the charge stored on the loop filter capacitors (both internal and external). The stored charge results in a voltage that sets the output frequency of the VCO. The feedback loop of the PLL causes the VCO control voltage to vary in such a way as to phase lock the PFD input signals. Note that the PFD supports input frequencies spanning 13.3 kHz to 100 MHz (implying that input frequencies between 8 kHz and 13.3 kHz must use the 2× frequency multiplier in the input path).

The PLL has a VCO with 128 frequency bands spanning a range of 3350 MHz to 4050 MHz (3700 MHz nominal). However, the actual operating frequency within a particular band depends on the control voltage that appears on the loop filter capacitor. The control voltage causes the VCO output frequency to vary linearly within the selected band. This frequency variability allows the control loop of the PLL to synchronize the VCO output signal with the reference signal applied to the PFD.

Typically, selection of the VCO frequency band (as well as gain adjustment) occurs automatically as part of the device's automatic VCO calibration process, which initiates at power up (or reset). Alternatively, the user can force VCO calibration by first enabling SPI control of VCO calibration (Register 0x0E[2] = 1) and then writing a 1 to the calibrate VCO bit (Register 0x0E[7]).

To facilitate system debugging, the user can override the VCO band setting by first enabling SPI control of VCO band (Register 0x0E[0] = 1) and then writing the desired value to Register 0x10[7:1].

The feedback divider (N-divider) sets the frequency multiplication factor of the PLL in integer steps over a 20-bit range. However, the N-divider has a lower limit of 32, which sets a minimum PLL multiplication factor of 32.

Loop Filter

The charge pump in the PFD delivers current to the loop filter (see Figure 22). The main components of the loop filter are external and connect between Pin 16 and Pin 17. Note that to achieve the best jitter performance in applications requiring a loop bandwidth of less than 1 kHz, C1 and C2 must have an insulation resistance of at least 500 Ω F.

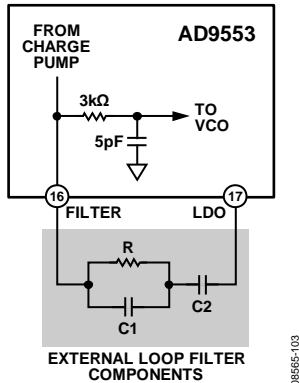

Figure 22. External Loop Filter

There are two recommended sets of external loop filter components (see Table 17) based on the A[3:0] pin configuration.

Table 17. External Loop Filter Components

Pins A[3:0]	R (k Ω)	C1	C2	Loop Bandwidth (kHz)
0001 to 1100	6.8	47 nF	1 μ F	0.17
1101 to 1110	12	51 pF	220 nF	75
1111	6.8	47 nF	1 μ F	0.17

PLL Locked Indicator

The PLL provides a status indicator that appears at Pin 20 (LOCKED). When the PLL acquires phase lock, the LOCKED pin switches to a Logic 1 state.

Alternatively, the LOCKED pin serves as a test port allowing the user to monitor one-of-four internal clocks. Register 0x17[3:1] controls the test port as shown in Table 18.

Table 18: LOCKED Pin Output Control

Register 0x17[3:1]	LOCKED Pin Output
0XX	PLL locked indication (default)
100	Crystal oscillator clock signal
101	PFD pump-up clock divided-by-2
110	PFD reference input clock divided-by-2
111	PLL feedback to PFD clock divided-by-2

Output Dividers

The output divider section consists of three dividers: P₀, P₁, and P₂. The P₀ divider (or VCO frequency prescaler) accepts the VCO frequency and reduces it by a factor of 5 or 6 (selectable). This brings the frequency down to a range between 558 MHz and 810 MHz.

The output of the P₀ divider independently drives the P₁ divider and the P₂ divider. The P₁ divider establishes the frequency at OUT1 and the P₂ divider establishes the frequency at OUT2. The P₁ and P₂ dividers are each programmable over a range of 1 to 1023, which results in a frequency at OUT1 or OUT2 that is an integer submultiple of the frequency at the output of the P₀ divider.

Output Driver Configuration

The user has complete control over all configurable parameters of the OUT1 and OUT2 drivers via the OUT1 and OUT2 driver control registers (Register 0x32 and Register 0x34, respectively, as shown in Figure 23). To alter the parameters from their default values, the user must use the SPI port to program the driver control registers as desired.

The OUT1 and OUT2 drivers are configurable in terms of the following parameters:

- Logic family (via mode control)
- Pin function (via mode control but only applies to the CMOS family)
- Polarity (only applies to the CMOS family)
- Drive current
- Power-down

Output Driver Mode Control

Three mode control bits establish the logic family and pin function of the output drivers. The three bits originate either from Bits[5:3] of Register 0x32 and Register 0x34 or from the decode logic associated with the OM[2:0] pins as shown in Figure 23. Note that Bit 0 of Register 0x32 and Register 0x34 determines the source of the three mode control bits for the associated output driver. Specifically, when Bit 0 of the register is Logic 0 (default), the source of the mode control bits for the associated driver is the OM[2:0] pin decoder. When Bit 0 is Logic 1, the source of the mode control bits is from Bits[5:3] of Register 0x32 and Register 0x34.

The mode control bits establish the logic family and output pin function of the associated output driver per Table 19. The logic families include LVDS, LVPECL, and CMOS. Because both output drivers support the LVDS and LVPECL logic families, each driver has two pins to handle the differential signals associated with these two logic families. The OUT1 driver uses the OUT1 and OUT1 pins and the OUT2 driver uses the OUT2 and OUT2 pins. However, the CMOS logic family handles only single-ended signals, thereby requiring only one pin. Even though CMOS only requires one pin, both pins of OUT1 and both pins of OUT2 have a dedicated CMOS driver.

The user has the option to disable (that is, tristate) either or both of the pins for OUT1 and/or OUT2 via the mode control bits (see Table 19, Bit Patterns 001, 010, and 011). Alternatively, the user can make both pins active (see Table 19, Bit Pattern 000) to produce two single-ended CMOS output clocks at OUT1 and/or OUT2.

Table 19. Output Mode Control Bits

Mode Control Bits	Logic Family	Pin Function of the Output Driver
000	CMOS	Both pins active
001	CMOS	Positive pin active, negative pin tristate
010	CMOS	Positive pin tristate, negative pin active
011	CMOS	Both pins tristate
100	LVDS	Both pins active
101	LVPECL	Both pins active
110	Unused	Unused
111	Unused	Unused

Note that the pin decoder for the OM[2:0] pins generates two sets of mode control bits: one set for the OUT1 driver and another set for the OUT2 driver. The relationship between the logic levels applied to the OM[2:0] pins and the resulting mode control bits appears in Table 20.

Table 20. OM[2:0] Pin Decoder

Pins OM[2:0]	Mode Control Bits	
	OUT1	OUT2
000	101	101
001	101	100
010	100	101
011	101	001
100	100	100
101	100	001
110	001	100
111	001	001

This decoding scheme allows the OM[2:0] pins to establish a matrix of logic family selections for the OUT1 and OUT2 drivers as shown in Table 21. Note that when the OM[2:0] pins select the CMOS logic family, only the positive pin active, negative pin tristate output driver pin function option is available.

Table 21. Logic Family Assignment via the OM[2:0] Pins

Pins OM[2:0]	Logic Family	
	OUT1	OUT2
000	LVPECL	LVPECL
001	LVPECL	LVDS
010	LVDS	LVPECL
011	LVPECL	CMOS
100	LVDS	LVDS
101	LVDS	CMOS
110	CMOS	LVDS
111	CMOS	CMOS

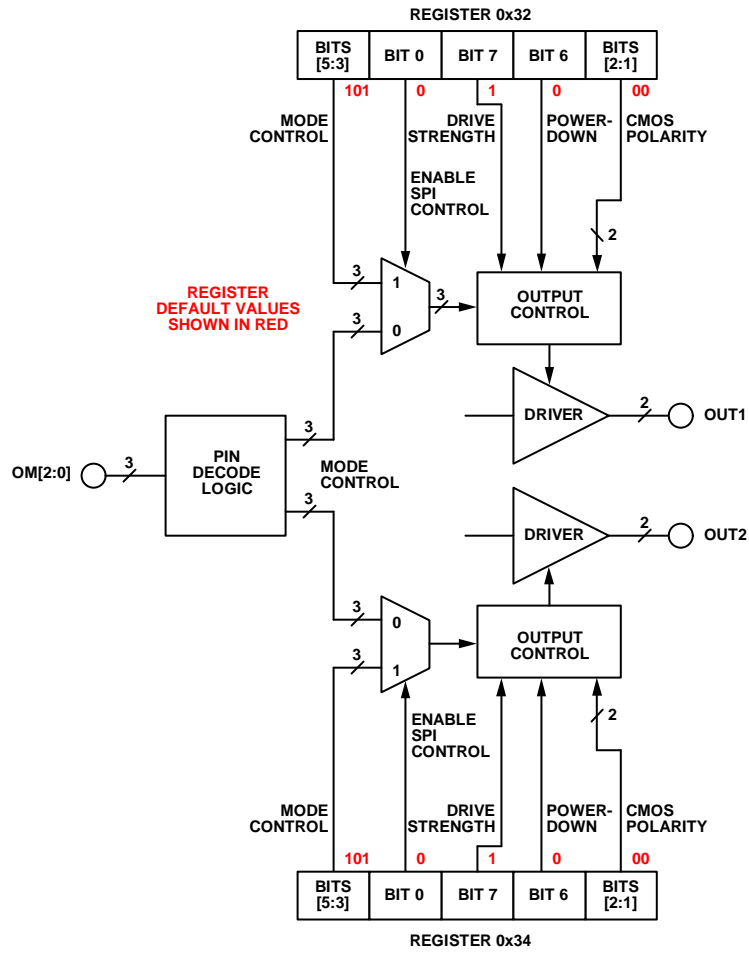

Figure 23. Output Driver Control

08555-104

Output Driver Polarity (CMOS)

When the mode control bits indicate the CMOS logic family (see Table 19), the user has control of the logic polarity associated with each CMOS output pin. Driver polarity defines how the logic level (Logic 1 or Logic 0) at a CMOS output pin relates to the logic state (Logic True or Logic False). Normal polarity equates Logic 1/Logic 0 to Logic True/Logic False, while inverted polarity equates Logic 0/Logic 1 to Logic True/Logic False. Bits[2:1] of the OUT1 and OUT2 driver control registers control the CMOS polarity of the associated output driver (see Figure 23).

Output Drive Strength (CMOS or LVDS)

When the mode bits indicate the CMOS or LVDS logic family (see Table 19), the user can select whether the output driver uses weak or strong drive capability. Bit 7 of the OUT1 and OUT2 driver control registers control the drive strength of the associated output driver (see Figure 23). In the case of the CMOS family, the strong setting allows for driving increased capacitive loads. In the case of the LVDS family, the nominal weak and strong drive currents are 3.5 mA and 7 mA, respectively.

Output Power Down

The AD9553 supports the option of independent power-down of the output drivers. Bit 6 of the OUT1 and OUT2 driver control registers controls the power-down function (see Figure 23). When Bit 6 is Logic 0, the associated output driver is active. When Bit 6 is Logic 1, the associated output driver is in power-down mode.

JITTER TOLERANCE

Jitter tolerance is the ability of the AD9553 to maintain lock in the presence of sinusoidal jitter. The AD9553 meets the input jitter tolerance mask per Telcordia GR-253-CORE (see Figure 24). The acceptable jitter tolerance is the region above the mask. The trace showing the performance of the AD9553 in Figure 24 represents the limitations of the test equipment because the AD9553 did not indicate loss of lock, even with the test equipment injecting its maximum jitter level.

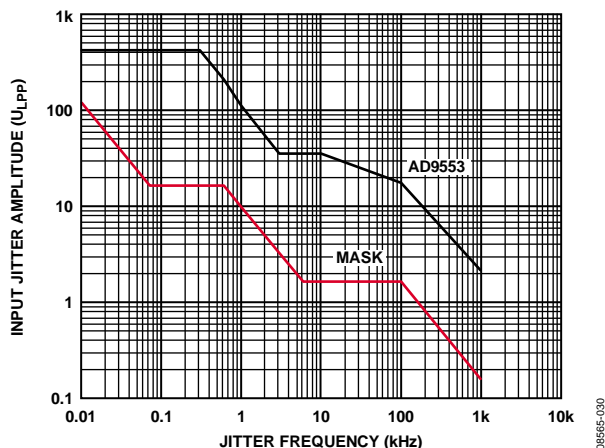

Figure 24. Jitter Tolerance

OUTPUT/INPUT FREQUENCY RELATIONSHIP

The frequency at OUT1 and OUT2 depends on the frequency at the input to the PLL, the PLL feedback divider value (N), and the output divider values (P_0 , P_1 , and P_2). The equations that define the frequency at OUT1 and OUT2 (f_{OUT1} and f_{OUT2} , respectively) are as follows:

$$f_{OUT1} = FPF D \left(\frac{N}{P_0 \times P_1} \right)$$

$$f_{OUT2} = FPF D \left(\frac{N}{P_0 \times P_2} \right)$$

where:

$FPFD$ is the frequency at the reference input of the PFD.

N is the feedback divider value.

P_0 is the VCO prescaler divider value.

P_1 is the OUT1 divider value.

P_2 is the OUT2 divider value.

The operating frequency range of the PFD places a limitation on $FPFD$ as follows:

$$13.3 \text{ kHz} \leq FPF D \leq 100 \text{ MHz}$$

Note that for applications using the frequency selection pins in conjunction with the XTAL input for the holdover function, the maximum value of $FPFD$ is 50 MHz (twice the 25 MHz default crystal frequency).

$FPFD$ depends on the input frequency to the AD9553, the configuration of the multiplexers for the /5 prescaler and 2 \times frequency multiplier, and the value of the R_X divider (either R_A , R_B , or R_{XO}) as follows:

$$FPFD = f_X \times \frac{K}{R_X}$$

where:

f_X is equal to f_{REFA} , f_{REFB} , or f_{XTAL} .

K is the scale factor per Table 22.

$FPFD$ is the frequency at the input to the phase frequency detector.

Table 22. K as a Function of Input Multiplexer Configuration

Input	/5	2 \times	K
REFA	Bypassed	Bypassed	1
	Active	Bypassed	1/5
	Bypassed	Active	2
	Active	Active	2/5
REFB	Bypassed	Bypassed	1
	Active	Bypassed	1/5
	Bypassed	Active	2
	Active	Active	2/5
XTAL	N/A	N/A	2

This leads to the complete frequency translation formula

$$f_{OUT1} = f_X \left(\frac{K}{R_X} \right) \left(\frac{N}{P_0 \times P_1} \right)$$

$$f_{OUT2} = f_X \left(\frac{K}{R_X} \right) \left(\frac{N}{P_0 \times P_2} \right)$$

Specific numeric constraints apply as follows. Note that the symbol \in indicates that the constraint is an element of one in the series from the list within the curly brackets.

$$K \in \left\{ \frac{1}{5}, \frac{2}{5}, 1, 2 \right\}$$

$$R_X \in \{1, 2, \dots, 16384\}$$

$$N \in \{32, 33, \dots, 1048576\}$$

$$P_0 \in \{5, 6\}$$

$$P_1 \in \{1, 2, \dots, 63\}$$

$$P_2 \in \{1, 2, \dots, 63\}$$

Additional constraints apply. One constraint is related to the VCO and the other to the $2\times$ frequency multipliers in the REFA and REFB paths. The VCO constraint is a consequence of its limited bandwidth. However, the $2\times$ frequency multiplier constraint only applies when the /5 prescalers are bypassed, but it also requires that R_A and R_B are large enough to satisfy the FPFD constraint. The additional constraints are as follows:

$$3350 \text{ MHz} \leq f_{OUT1} \times P_0 \times P_1 \leq 4050 \text{ MHz}$$

$$3350 \text{ MHz} \leq f_{OUT2} \times P_0 \times P_2 \leq 4050 \text{ MHz}$$

$$f_{REFA/B} \leq 125 \text{ MHz (} 2\times \text{ multiplier with /5 bypassed)}$$

Generally, the AD9553 is for applications in which f_{REFA} and f_{REFB} are the same frequency, so the multiplexers in the REFA and REFB paths share identical configurations. This, in conjunction with the crystal frequency (f_{XTAL}), results in the following relationship between the R_A and R_{XO} dividers (here K is the scale factor for the REFA path).

$$\frac{2 \times f_{XTAL}}{f_{REFA}} = K \times \frac{R_{XO}}{R_A}$$

Note that for pin-programmed holdover applications using the crystal, the crystal frequency must be 25 MHz. Under these circumstances, the above equation simplifies as follows:

$$\frac{50 \times 10^6}{f_{REFA}} = K \times \frac{R_{XO}}{R_A}$$

CALCULATING DIVIDER VALUES

This section describes the process of calculating the divider values when given a specific f_{OUT1}/f_{REF} ratio (f_{REF} is the frequency of either the REFA or REFB input signal source or the external crystal resonator). This description is in general terms, but it includes a specific example for clarity. The example assumes a frequency control pin setting of $A[3:0] = 1011$ (see Table 14) and $Y[5:0] = 011100$ (see Table 15), yielding the following:

$$f_{REF} = 125 \text{ MHz}$$

$$f_{OUT1} = 155.52 \text{ MHz}$$

Follow these steps to calculate the divider values.

- Determine the output divide factor (ODF).
Note that the VCO frequency (f_{VCO}) spans 3350 MHz to 4050 MHz. The ratio, f_{VCO}/f_{OUT1} , indicates the required ODF. Given the specified value of f_{OUT1} (155.52 MHz) and the range of f_{VCO} , the ODF spans a range of 21.54 to 26.04. The ODF must be an integer, which means that ODF is 22, 23, 24, 25, or 26.

- Determine suitable values for P_0 , P_1 and f_{VCO} .
The ODF is the product of the two output dividers P_0 and P_1 ($ODF = P_0P_1$). However, P_0 is constrained to 5 or 6 (see the Output/Input Frequency Relationship section), which means that there are only two possibilities for ODF in this example: $ODF = 24$ ($P_0 = 6$, $P_1 = 4$) and $ODF = 25$ ($P_0 = 5$, $P_1 = 5$). These two ODF values result in the only VCO frequencies that satisfy the 155.52 MHz requirement for OUT1 (3732.48 MHz for $ODF = 24$ and 3888 MHz for $ODF = 25$). The results appear below. Note that the first result agrees with Table 15 in the Preset Frequencies section).

$$P_0 = 6, P_1 = 4 (f_{VCO} = 3732.48 \text{ MHz})$$

$$P_0 = 5, P_1 = 5 (f_{VCO} = 3888 \text{ MHz})$$

- Determine the boundary conditions on N , K , and R .
Because of the architecture of the PLL, FPFD must be an integer submultiple of the VCO frequency as shown in the following equation. Note that N is an integer and is the 20-bit value of the N -divider.

$$FPFD = \frac{f_{VCO}}{N}$$

This relationship leads to boundary conditions on N because N must be an integer that satisfies $N = f_{VCO}/FPFD$. The limits on FPFD (13.3 kHz to 100 MHz) combined with the results for f_{VCO} from Step 2 yield

$$N = 38\dots280,637 \text{ (for } f_{VCO} = 3732.48 \text{ MHz)}$$

$$N = 39\dots292,330 \text{ (for } f_{VCO} = 3888 \text{ MHz)}$$

Note that FPFD also relates to the input frequency, f_{REF} , per the following equation. Here, R is the 14-bit integer division factor of the input divider (R_A or R_B), while K is the scale factor associated with the optional $2\times$ multiplier and divide-by-five functions. Note that K can only be one of four values: 1/5, 2/5, 1, or 2.

$$FPFD = f_{REF} \left(\frac{K}{R} \right)$$

This relationship leads to boundary conditions on R because $R/K = f_{REF}/FPFD$ where R must be an integer and K can only be 1/5, 2/5, 1, or 2. The limits on FPFD (13.3 kHz to 100 MHz) combined with the given value of f_{REF} yield the following bounds on R . Note that for $K = 2$, the upper bound on R is limited by its 14-bit range.

$$R = 1 \dots 1,879 \text{ (for } K = 1/5)$$

$$R = 1 \dots 3,759 \text{ (for } K = 2/5)$$

$$R = 2 \dots 9,398 \text{ (for } K = 1)$$

$$R = 3 \dots 16,384 \text{ (for } K = 2)$$

4. Relate N, K, and R to the frequency requirements.

The two FPDF equations in Step 3 show that f_{VCO} and f_{REF} relate as

$$\frac{f_{VCO}}{f_{REF}} = \frac{NK}{R}$$

Note that f_{REF} is a known quantity (125 MHz) and the VCO frequencies were determined in Step 2 as 3732.48 MHz and 3888 MHz. Based on these values of f_{REF} and f_{VCO}

$$\frac{3732.48}{125} = \frac{NK}{R} \quad \text{or} \quad \frac{3888}{125} = \frac{NK}{R}$$

5. Determine N, K, and R.

For $f_{VCO} = 3888$ MHz, an obvious solution is $K = 1$, $R = 125$ and $N = 3888$, which satisfies the constraint on both N and R and yields $\text{FPFD} = 1$ MHz.

For $f_{VCO} = 3732.48$ MHz, an obvious solution is $N = 373,248$, $K = 1$ and $R = 12,500$. This choice, however, violates the constraints on both N and R in Step 3.

A simple remedy is to divide both N and R by a common factor. In this particular case, four is the greatest common factor of N and R. Dividing by four leads to $N = 93,312$, $K = 1$, and $R = 3,125$ ($K = 1$), satisfying the constraint on N and R, and yielding $\text{FPFD} = 40$ kHz. Note that to match the values given in the Preset Frequencies section, FPFD must be 16 kHz. To accomplish this, keep $R = 3,125$, but choose $K = 2/5$ (see Table 14). This changes N to 233,280, which agrees with Table 16. In summary, if one chooses $f_{VCO} = 3732.48$ MHz, then the solution set that matches the tables in the Preset Frequencies section is

$$P_0 = 6$$

$$P_1 = 4$$

$$N = 233,280$$

$$R = 3,125$$

$$K = 2/5$$

$$\text{FPFD} = 16 \text{ kHz}$$

If one chooses $f_{VCO} = 3888$ MHz, then a possible solution is

$$P_0 = 5$$

$$P_1 = 5$$

$$N = 3888$$

$$R = 125$$

$$K = 1$$

$$\text{FPFD} = 1 \text{ MHz}$$

6. If applicable, determine R_{XO} , the XTAL divider value. The value of R_{XO} depends on the value of f_{REF} , K, and R from Step 5, as follows:

$$R_{XO} = \left(\frac{50 \times 10^6}{f_{REF}} \right) \left(\frac{R}{K} \right)$$

Given that $f_{REF} = 125$ MHz, the two results from Step 5 lead to

$$R_{XO} = 3125 \text{ (for } R = 3125 \text{ and } K = 2/5)$$

$$R_{XO} = 50 \text{ (for } R = 125 \text{ and } K = 1)$$

LOW DROPOUT (LDO) REGULATORS

The AD9553 is powered from a single 3.3 V supply and contains on-chip LDO regulators for each function to eliminate the need for external LDOs. To ensure optimal performance, each LDO output should have a 0.47 μF capacitor connected between its access pin and ground.

AUTOMATIC POWER-ON RESET

The AD9553 has an internal power-on reset circuit (see Figure 25). At power-up, an 800 pF capacitor momentarily holds a Logic 0 at the active low input of the reset circuitry. This ensures that the device is held in a reset state ($\sim 250 \mu\text{s}$) until the capacitor charges sufficiently via the 100 k Ω pull-up resistor and 200 k Ω series resistor. Note that when using a low impedance source to drive the $\overline{\text{RESET}}$ pin, be sure that the source is either tristate or Logic 0 at power-up. Otherwise, the device may not calibrate properly.

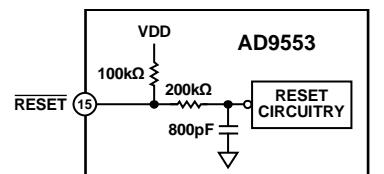

Figure 25. Power-On Reset

APPLICATIONS INFORMATION

THERMAL PERFORMANCE

The AD9553 is specified for a case temperature (T_{CASE}). To ensure that T_{CASE} is not exceeded, an airflow source can be used. Use the following equation to determine the junction temperature on the application PCB:

$$T_j = T_{CASE} + (\Psi_{JT} \times P_D)$$

where:

T_j is the junction temperature ($^{\circ}C$).

T_{CASE} is the case temperature ($^{\circ}C$) measured by the customer at the top center of the package.

Ψ_{JT} is the value indicated in Table 23.

P_D is the power dissipation (see the Power Consumption section).

Values of θ_{JA} are provided for package comparison and PCB design considerations. θ_{JA} can be used for a first-order approximation of T_j using the following equation:

$$T_j = T_A + (\theta_{JA} \times P_D)$$

where T_A is the ambient temperature ($^{\circ}C$).

Values of θ_{JC} are provided for package comparison and PCB design considerations when an external heat sink is required.

Values of θ_{JB} are provided for package comparison and PCB design considerations.

Table 23. Thermal Parameters for the 32-Lead LFCSP Package

Symbol	Description	Value ¹	Unit
θ_{JA}	Junction-to-ambient thermal resistance, 0 m/sec airflow per JEDEC JESD51-2 (still air)	41.6	$^{\circ}C/W$
θ_{JMA}	Junction-to-ambient thermal resistance, 1.0 m/sec airflow per JEDEC JESD51-6 (moving air)	36.4	$^{\circ}C/W$
θ_{JMA}	Junction-to-ambient thermal resistance, 2.5 m/sec airflow per JEDEC JESD51-6 (moving air)	32.6	$^{\circ}C/W$
θ_{JB}	Junction-to-board thermal resistance, 0 m/sec airflow per JEDEC JESD51-8 (still air)	24.2	$^{\circ}C/W$
Ψ_{JB}	Junction-to-board characterization parameter, 0 m/sec airflow per JEDEC JESD51-6 (still air)	22.9	$^{\circ}C/W$
θ_{JC}	Junction-to-case thermal resistance	4.8	$^{\circ}C/W$
Ψ_{JT}	Junction-to-top-of-package characterization parameter, 0 m/sec airflow per JEDEC JESD51-2 (still air)	0.5	$^{\circ}C/W$

¹ Results are from simulations. The PCB is a JEDEC multilayer type. Thermal performance for actual applications requires careful inspection of the conditions in the application to determine whether they are similar to those assumed in these calculations.

SERIAL CONTROL PORT

The AD9553 serial control port is a flexible, synchronous, serial communications port that allows an easy interface to many industry-standard microcontrollers and microprocessors. Single or multiple byte transfers are supported, as well as MSB first or LSB first transfer formats. The AD9553 serial control port is configured for a single bidirectional I/O pin (SDIO only). The serial control port uses 16-bit instructions, which allows access to the entire register address range (0x00 to 0x34).

The serial control port has two types of registers: read-only and buffered. Read-only registers are nonbuffered and ignore write commands. All writable registers are buffered (also referred to as mirrored) and require an I/O update to transfer the new values from a temporary buffer on the chip to the actual register. To invoke an I/O update, write a 1 to the I/O update bit found in Register 0x05[0]. Because any number of bytes of data can be changed before issuing an update command, the update simultaneously enables all register changes occurring since any previous update.

SERIAL CONTROL PORT PIN DESCRIPTIONS

The serial data clock (SCLK) is the serial shift clock. This pin is an input. SCLK is used to synchronize serial control port reads and writes. Write data bits are registered on the rising edge of this clock, and read data bits are registered on the falling edge.

The digital serial data input/output (SDIO) pin is a dual-purpose pin that acts as input only or as an input/output. The AD9553 defaults to bidirectional pins for I/O.

The chip select bar (\overline{CS}) is an active low control that gates the read and write cycles. When \overline{CS} is high, SDIO is in a high impedance state. See the Operation of the Serial Control Port section on the use of the \overline{CS} pin in a communication cycle.

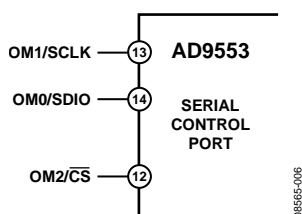

Figure 26. Serial Control Port

OPERATION OF THE SERIAL CONTROL PORT

Framing a Communication Cycle with \overline{CS}

The \overline{CS} line gates the communication cycle (a write or a read operation). \overline{CS} must be brought low to initiate a communication cycle.

The \overline{CS} stall high function is supported in modes where three or fewer bytes of data (plus instruction data) are transferred. Bits[W1:W0] must be set to 00, 01, or 10 (see Table 24). In these modes, \overline{CS} may temporarily return high on any byte boundary, allowing time for the system controller to process the next byte. \overline{CS} can go high on byte boundaries only and can go high during either part (instruction or data) of the transfer. During this period,

the serial control port state machine enters a wait state until all data has been sent. If the system controller decides to abort before the complete transfer of all the data, the state machine must be reset either by completing the remaining transfer or by returning the \overline{CS} line low for at least one complete SCLK cycle (but fewer than eight SCLK cycles). A rising edge on the \overline{CS} pin on a nonbyte boundary terminates the serial transfer and flushes the buffer.

Table 24. Byte Transfer Count

Bit W1	Bit W0	Bytes to Transfer (Excluding the 2-Byte Instruction)
0	0	1
0	1	2
1	0	3
1	1	Streaming mode

In the streaming mode (Bits[W1:W0] = 11), any number of data bytes can be transferred in a continuous stream. The register address is automatically incremented or decremented (see the MSB/LSB First Transfers section). \overline{CS} must be raised at the end of the last byte to be transferred, thereby ending the stream mode.

Communication Cycle—Instruction Plus Data

There are two parts to a communication cycle with the AD9553. The first part writes a 16-bit instruction word into the AD9553, coincident with the first 16 SCLK rising edges. The instruction word provides the AD9553 serial control port with information regarding the data transfer, which is the second part of the communication cycle. The instruction word defines whether the upcoming data transfer is a read or a write, the number of bytes in the data transfer, and the starting register address for the first byte of the data transfer.

Write

If the instruction word is for a write operation (Bit I15 = 0), the second part is the transfer of data into the serial control port buffer of the AD9553. The length of the transfer (1, 2, or 3 bytes; or streaming mode) is indicated by two bits (Bits[W1:W0]) in the instruction byte. The length of the transfer indicated by (Bits[W1:W0]) does not include the 2-byte instruction. \overline{CS} can be raised after each sequence of eight bits to stall the bus (except after the last byte, where it ends the cycle). When the bus is stalled, the serial transfer resumes when \overline{CS} is lowered. Stalling on nonbyte boundaries resets the serial control port.

Read

If the instruction word is for a read operation (Bit I15 = 1), the next $N \times 8$ SCLK cycles clock out the data from the address specified in the instruction word, where N is 1, 2, 3, or 4, as determined by Bits[W1:W0]. In this case, 4 is used for streaming mode, where four or more words are transferred per read. The data read back is valid on the falling edge of SCLK.

The default mode of the AD9553 serial control port is bidirectional mode, and the data readback appears on the SDIO pin.

AD9553

By default, a read request reads the register value that is currently in use by the AD9553. However, setting Register 0x04[0] = 1 causes the buffered registers to be read instead. The buffered registers are the ones that take effect during the next I/O update.

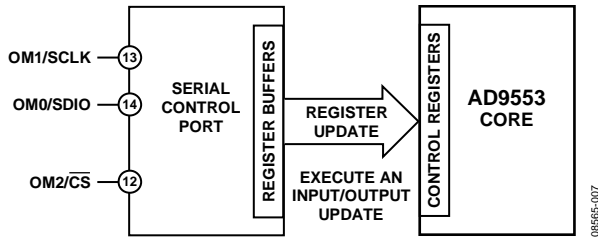

Figure 27. Relationship Between the Serial Control Port Register Buffers and the Control Registers

INSTRUCTION WORD (16 BITS)

The MSB of the instruction word (see Table 25) is $\overline{R/W}$, which indicates whether the instruction is a read or a write. The next two bits, W1 and W0, are the transfer length in bytes. The final 13 bits are the address bits (Address Bits[A12:A0]) at which the read or write operation is to begin.

For a write, the instruction word is followed by the number of bytes of data indicated by Bits[W1:W0], which is interpreted according to Table 24.

Address Bits[A12:A0] select the address within the register map that is written to or read from during the data transfer portion of the communication cycle. The AD9553 uses all of the 13-bit address space. For multibyte transfers, this address is the starting byte address.

Table 25. Serial Control Port, 16-Bit Instruction Word, MSB First

MSB													LSB		
I15	I14	I13	I12	I11	I10	I9	I8	I7	I6	I5	I4	I3	I2	I1	I0
$\overline{R/W}$	W1	W0	A12	A11	A10	A9	A8	A7	A6	A5	A4	A3	A2	A1	A0

Table 26. Definition of Terms Used in Serial Control Port Timing Diagrams

Parameter	Description
t_{CLK}	Period of SCLK
t_{DV}	Read data valid time (time from falling edge of SCLK to valid data on SDIO)
t_{DS}	Setup time between data and rising edge of SCLK
t_{DH}	Hold time between data and rising edge of SCLK
t_S	Setup time between \overline{CS} and SCLK
t_H	Hold time between \overline{CS} and SCLK
t_{HIGH}	Minimum period that SCLK should be in a logic high state
t_{LOW}	Minimum period that SCLK should be in a logic low state

MSB/LSB FIRST TRANSFERS

The AD9553 instruction word and byte data can be MSB first or LSB first. The default for the AD9553 is MSB first. The LSB first mode can be set by writing a 1 to Register 0x00[6] and requires that an I/O update be executed. Immediately after the LSB first bit is set, all serial control port operations are changed to LSB first order.

When MSB first mode is active, the instruction and data bytes must be written from MSB to LSB. Multibyte data transfers in MSB first format start with an instruction byte that includes the register address of the most significant data byte. Subsequent data bytes must follow in order from high address to low address. In MSB first mode, the serial control port internal address generator decrements for each data byte of the multibyte transfer cycle.

When LSB first = 1 (LSB first), the instruction and data bytes must be written from LSB to MSB. Multibyte data transfers in LSB first format start with an instruction byte that includes the register address of the least significant data byte followed by multiple data bytes. The serial control port internal byte address generator increments for each data byte of the multibyte transfer cycle.

The AD9553 serial control port register address decrements from the register address just written toward 0x00 for multibyte I/O operations if the MSB first mode is active (default). If the LSB first mode is active, the serial control port register address increments from the address just written toward 0x34 for multibyte I/O operations.

Unused addresses are not skipped during multibyte I/O operations. The user should write the default value to a reserved register and should write only zeros to unmapped registers. Note that it is more efficient to issue a new write command than to write the default value to more than two consecutive reserved (or unmapped) registers.

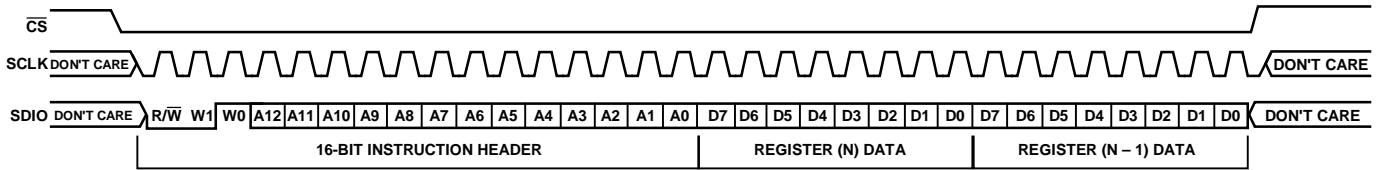

Figure 28. Serial Control Port Write—MSB First, 16-Bit Instruction, Two Bytes Data

08955-008

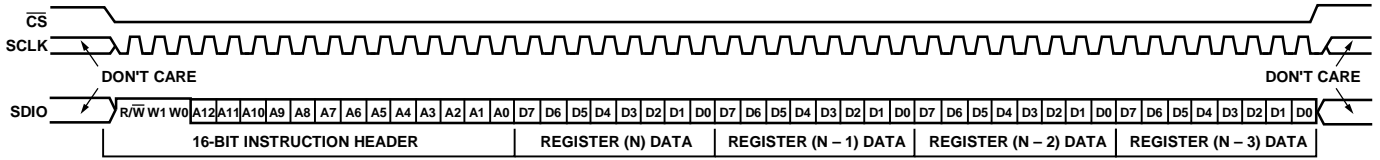

Figure 29. Serial Control Port Read—MSB First, 16-Bit Instruction, Four Bytes Data

08955-009

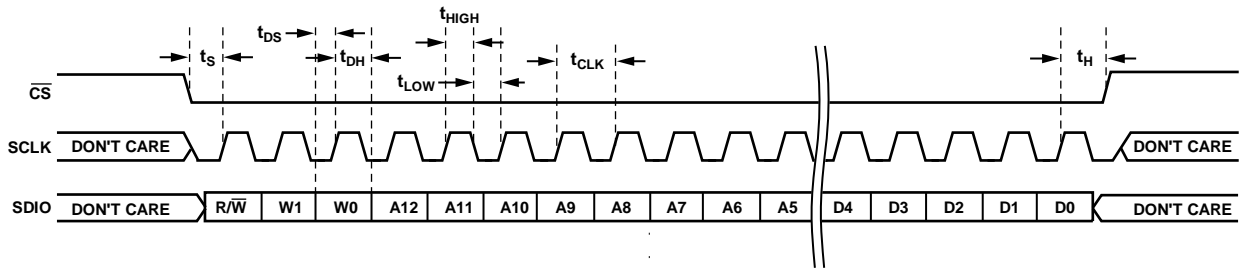

Figure 30. Serial Control Port Write—MSB First, 16-Bit Instruction, Timing Measurements

08955-010

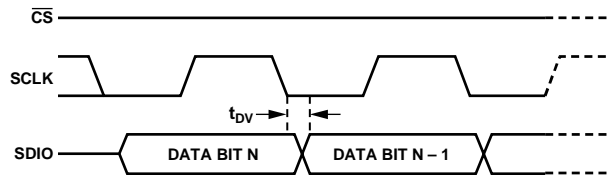

Figure 31. Timing Diagram for Serial Control Port Register Read

08955-011

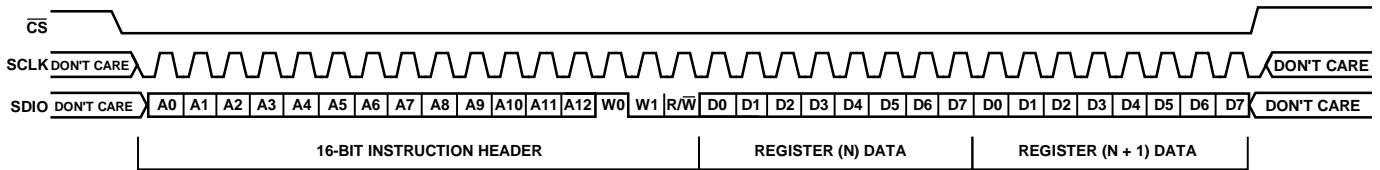

Figure 32. Serial Control Port Write—LSB First, 16-Bit Instruction, Two Bytes Data

08955-012

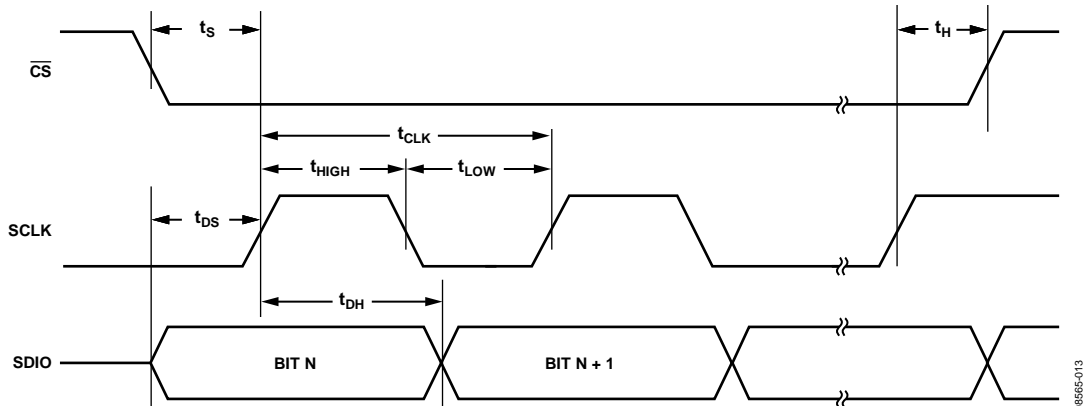

Figure 33. Serial Control Port Timing—Write

08955-013

REGISTER MAP

A bit that labeled “aclr” is an active high, autoclearing bit. When set to a Logic 1 state, the control logic automatically returns it to a Logic 0 state upon completion of the indicated task.

Table 27. Register Map

Addr. (Hex)	Register Name	(MSB) Bit 7	Bit 6	Bit 5	Bit 4	Bit 3	Bit 2	Bit 1	(LSB) Bit 0	Default
0x00	Serial port control	0	LSB first	Soft reset (aclr)	1	1	Soft reset	LSB first	0	0x18
0x04	Readback control	Unused	Unused	Unused	Unused	Unused	Unused	Unused	Readback control	0x00
0x05	I/O update	Unused	Unused	Unused	Unused	Unused	Unused	Unused	I/O update (aclr)	0x00
0x0A	PLL charge pump and PFD control	Charge pump current control[7:0] (3.5 μ A granularity, ~900 μ A full scale)								0x80
0x0B		Enable SPI control of charge pump current	Enable SPI control of antiback-lash period	Charge pump mode[1:0]		Disable charge pump	PFD feedback input edge control	PFD reference input edge control	Force VCO to midpoint frequency	0x30
0x0C		Unused	Unused	Unused	Unused	Unused	Charge pump clock div[2:0]			0x00
0x0D		Antibacklash control[1:0]		Unused	Unused	Unused	Unused	Unused	PLL lock detector power-down	0x00
0x0E		VCO control	Calibrate VCO (aclr)	Enable ALC	ALC threshold[2:0]			Enable SPI control of VCO calibration	Boost VCO supply	Enable SPI control of VCO band setting
0x0F	VCO level control[5:0]							Unused	Unused	0x80
0x10	VCO band control[6:0]								Unused	0x80
0x11	PLL and output frequency control	Unused	Unused	Unused	Unused	Unused	Unused	Unused	Unused	0x00
0x12		Feedback divider (N)[19:12]								0x80
0x13		Feedback divider (N)[11:4]								0x00
0x14		Feedback divider (N) [3:0]				Enable SPI control of feedback divider	Enable SPI control of output dividers	Unused	Reset PLL (aclr)	0x00
0x15		P ₁ divider[9:2]								0x20
0x16		P ₁ divider[1:0]	P ₂ divider[9:4]						0x00	
0x17		P ₂ divider[3:0]				Enable test port	Test mux[1:0]		Unused	0x01
0x18		0	P ₀ divider[1:0]	Unused	Unused	Unused	Unused	Unused	Unused	0x00
0x19	Unused	Unused	Unused	Unused	Unused	Unused	Unused	Unused	0x20	
0x1A	Input receiver and band gap control	Reference reset (aclr)	Band gap voltage adjust[4:0] (00000 = maximum, 11111 = minimum)					Unused	Enable SPI control of band gap voltage	0x00
0x1B	XTAL control	Disable SPI control of XTAL tuning capacitance	0	XTAL tuning capacitor control[5:0] (0.25 pF per bit, inverted binary coding)						0x80
0x1C		Unused	Unused	Unused	Unused	Unused	Unused	Unused	0x00	
0x1D		Unused	Unused	Unused	Unused	Unused	Unused	Unused	0x00	
0x1E	Unused	Unused	Unused	Unused	Unused	Unused	Unused	Unused		

Addr. (Hex)	Register Name	(MSB) Bit 7	Bit 6	Bit 5	Bit 4	Bit 3	Bit 2	Bit 1	(LSB) Bit 0	Default
0x1F	REFA frequency control	REFA divider (R _A)[13:6]								0x40
0x20		REFA divider (R _A) [5:0]						Enable SPI control of R _A	Unused	0x00
0x21		Enable SPI control of x2 _A	Select x2 _A	Enable SPI control of /5 _A	Select /5 _A	Unused	Unused	Unused	Unused	0x00
0x22	Unused	Unused	Unused	Unused	Unused	Unused	Unused	Unused	Unused	
0x23	REFB frequency control	REFB divider (R _B)[13:6]								0x80
0x24		REFB divider (R _B)[5:0]						Enable SPI control of R _B	Unused	0x00
0x25		Enable SPI control of x2 _B	Select x2 _B	Enable SPI control of /5 _B	Select /5 _B	Unused	Unused	Unused	Unused	0x00
0x26	Unused	Unused	Unused	Unused	Unused	Unused	Unused	Unused	Unused	
0x27	DCXO frequency and reference switchover control	XO divider (R _{XO})[13:6]								0x40
0x28		XO divider (R _{XO})[5:0]						Enable SPI control of R _{XO}	Unused	0x00
0x29		Switchover mode[1:0]		REFA Diff	Unused	Unused	Unused	Unused	Unused	0x00
0x2A to 0x31	Unused	Unused	Unused	Unused	Unused	Unused	Unused	Unused	Unused	
0x32	OUT1 driver control	OUT1 drive strength	OUT1 power-down	OUT1 mode control[2:0]			OUT1 CMOS polarity[1:0]		Use Bits[5:3] as source for OUT1 mode control	0xA8
0x33	Unused	Unused	Unused	Unused	Unused	Unused	Unused	Unused	Unused	0x00
0x34	OUT2 driver control	OUT2 drive strength	OUT2 power-down	OUT2 mode control[2:0]			OUT2 CMOS polarity[1:0]		Use Bits[5:3] as source for OUT2 mode control	0xA8

REGISTER MAP DESCRIPTIONS

Control bit functions are active high unless stated otherwise. Register address values are always hexadecimal unless otherwise indicated.

Serial Port Control (Register 0x00 to Register 0x05)

Table 28.

Address	Bit	Bit Name	Description
0x00	7	Unused	Forced to Logic 0 internally, which enables 3-wire mode only.
	6	LSB first	Bit order for SPI port. 0 = most significant bit and byte first (default). 1 = least significant bit and byte first.
	5	Soft reset	Software initiated reset (register values set to default). This is an autoclearing bit.
	4	Unused	Forced to Logic 1 internally, which enables 16-bit mode (the only mode supported by the device).
	[3:0]	Unused	Mirrored version of the contents of Register 0x00[7:4] (that is, Bits[3:0] = Bits[7:4]).
0x04	[7:1]	Unused	Unused.
	0	Readback control	For buffered registers, serial port readback reads from actual (active) registers instead of from the buffer. 0 = reads values currently applied to the internal logic of the device (default). 1 = reads buffered values that take effect on next assertion of I/O update.
0x05	[7:1]	Unused	Unused.
	0	I/O update	Writing a 1 to this bit transfers the data in the serial I/O buffer registers to the internal control registers of the device. This is an autoclearing bit.

PLL Charge Pump and PFD Control (Register 0x0A to Register 0x0D)

Table 29.

Address	Bit	Bit Name	Description
0x0A	[7:0]	Charge pump current control	These bits set the magnitude of the PLL charge pump current. The granularity is ~3.5 μ A with a full-scale magnitude of ~900 μ A. Default is 0x80, or ~448 μ A. Register 0x0A is ineffective unless Register 0x0B[7] = 1.
0x0B	7	Enable SPI control of charge pump current	Controls the functionality of Register 0x0A. 0 = charge pump current based on A[3:0] and Y[5:0] pins per Table 16 (default). 1 = charge pump current defined by Register 0x0A.
	6	Enable SPI control of antibacklash period	Controls the functionality of Register 0x0D[7:6]. 0 = the device automatically controls the antibacklash period (default). 1 = antibacklash period defined by Register 0x0D[7:6].
	[5:4]	Charge pump mode	Controls the mode of the PLL charge pump. 00 = tristate. 01 = pump up. 10 = pump down. 11 = normal (default).
	3	Disable charge pump	Disables the charge pump (functionally equivalent to Register 0x0B[5:4] = 00). 0 = normal operation (default). 1 = disable charge pump.
	2	PFD feedback input edge control	Selects the polarity of the active edge of the PLL's feedback input. 0 = positive edge (default). 1 = negative edge.
	1	PFD reference input edge control	Selects the polarity of the active edge of the PLL's reference input. 0 = positive edge (default). 1 = negative edge.
	0	Force VCO to midpoint frequency	Selects VCO control voltage functionality. 0 = normal VCO operation (default). 1 = force VCO control voltage to midscale.

Address	Bit	Bit Name	Description
0x0C	[7:3]	Unused	Unused.
	[2:0]	Charge Pump Clock Div	Enables the PFD clock dividers (used for test only via test mux). 000 = test clocks disabled, normal operation (default). 001 = divide feedback clock by 2. 010 = divide PFD reference input clock by 2. 011 = divide PFD reference input and feedback clocks by 2. 100 = divide pump-up clock by 2. 101 = divide pump-up and feedback clocks by 2. 110 = divide pump-up and PFD reference input clocks by 2. 111 = divide feedback, pump-up, and pump-down clocks by 2.
0x0D	[7:6]	Antibacklash control	Controls the PFD antibacklash period of the PLL. These bits are ineffective unless Register 0x0B[6] = 1. 00 = minimum (default). 01 = low. 10 = high. 11 = maximum.
	[5:1]	Unused	Unused.
	0	PLL lock detector power-down	Controls power-down of the PLL lock detector. 0 = lock detector active (default). 1 = lock detector powered down.

VCO Control (Register 0x0E to Register 0x10)

Table 30.

Address	Bit	Bit Name	Description
0x0E	7	Calibrate VCO	Initiates VCO calibration (this is an autoclearing bit). This bit is ineffective unless Register 0x0E[2] = 1.
	6	Enable ALC	Enables automatic level control (ALC) of the VCO. 0 = Register 0x0F[7:2] defines the VCO level. 1 = the device automatically controls the VCO level (default).
	[5:3]	ALC threshold	Controls the VCO ALC threshold detector level from minimum (000) to maximum (111). The default is 110.
	2	Enable SPI control of VCO calibration	Enables the functionality of Register 0x0E[7]. 0 = the device automatically performs VCO calibration (default). 1 = VCO calibration controlled by Register 0x0E[7].
	1	Boost VCO supply	Selects VCO supply voltage. 0 = normal supply voltage (default). 1 = increase supply voltage by 100 mV.
	0	Enable SPI control of VCO band setting	Controls VCO band setting functionality. 0 = the device automatically selects the VCO band (default). 1 = VCO band defined by Register 0x10[7:1].
0x0F	[7:2]	VCO level control	Controls the VCO amplitude from minimum (00 0000) to maximum (11 1111). The default is 10 0000. These bits are ineffective unless Register 0x0E[6] = 0.
	[1:0]	Unused	Unused.
0x10	[7:1]	VCO band control	Controls the VCO frequency band from minimum (000 0000) to maximum (111 1111). The default is 100 0000. These bits are ineffective unless Register 0x0E[0] = 1.
	0	Unused	Unused.

PLL and Output Frequency Control (Register 0x11 to Register 0x19)

Table 31.

Address	Bit	Bit Name	Description
0x11	[7:0]	Unused	Unused.
0x12	[7:0]	Feedback divider (N)	Bits[19:12] of the 20-bit feedback divider (N).
0x13	[7:0]	Feedback divider (N)	Bits[11:4] of the 20-bit feedback divider (N).
0x14	[7:4]	Feedback divider (N)	Bits[3:0] of the 20-bit feedback divider (N). Default is N = 0x80000 (524,288). The feedback divider bits are ineffective unless Register 0x14[3] = 1.
	3	Enable SPI control of feedback divider	Enables SPI port control of the feedback divider value (N). 0 = The A[3:0] and Y[5:0] pins define N per Table 16 (default). 1 = The 20-bit value in the feedback divider register defines N.
	2	Enable SPI control of output dividers	Enables SPI port control of the output dividers P ₀ , P ₁ , and P ₂ . 0 = The Y[5:0] pins define the output divider values per Table 15 (default). 1 = The SPI port registers (0x15, 0x16, 0x18) define the output divider values.
	1	Unused	Unused.
	0	Reset PLL	Controls initialization of the PLL. 0 = normal operation (default). 1 = resets the counters and logic associated with the PLL but does not affect the output dividers.
0x15	[7:0]	P ₁ divider	Bits[9:2] of the 11-bit P ₁ divider.
0x16	[7:6]	P ₁ divider	Bits[1:0] of the 11-bit P ₁ divider (the default P ₁ divider register value is 128 decimal). The P ₁ divider bits are ineffective unless Register 0x14[2] = 1.
	[5:0]	P ₂ divider	Bits[9:4] of the 11-bit P ₂ divider.
0x17	[7:4]	P ₂ divider	Bits[3:0] of the 11-bit P ₂ divider. The P ₂ divider bits are ineffective unless Register 0x14[2] = 1.
	3	Enable test port	Enables use of the LOCKED pin as a test port. 0 = the LOCKED pin indicates PLL status (default). 1 = the LOCKED pin outputs a test signal per Register 0x17[2:1].
	[2:1]	Test Mux	Test mux select bits. 00 = crystal oscillator output (XO). 01 = PFD pump up clock divided-by-2 (UP/2). 10 = PFD reference input clock divided-by-2 (FPPD/2). 11 = PFD feedback clock divided-by-2 (FDBK/2).
0x18	0	Unused	Unused.
	7	Unused	When programming this register write a Logic 0 to this bit.
	[6:5]	P ₀ divider	Sets the P ₀ divider to divide-by-5 or divide-by-6. 00 = invalid. 01 = divide-by-5. 10 = divide-by-6. 11 = invalid. The P ₀ divider bits are ineffective unless Register 0x14[2] = 1.
	[4:0]	Unused	Unused.
0x19	[7:0]	Unused	Unused.

Input Receiver and Band Gap Control (Register 0x1A)

Table 32.

Address	Bit	Bit Name	Description
0x1A	7	Receiver reset	Input receiver reset control. This is an autoclearing bit. 0 = normal operation (default). 1 = resets the reference input hardware (detectors, dividers, switchover control, crystal oscillator and its associated frequency doubler).
	[6:2]	Band gap voltage adjust	Controls the band gap voltage setting from minimum (00000) to maximum (11111). Default is 00000. The band gap voltage adjust bits are ineffective unless Register 0x1A[0] = 1.
	1	Unused	Unused.
	0	Enable SPI control of band gap voltage	Enables functionality of Register 0x1A[6:2]. 0 = the device automatically selects receiver band gap voltage (default). 1 = Register 0x1A[6:2] defines the receiver band gap voltage.

XTAL Control (Register 0x1B to Register 0x1E)

Table 33.

Address	Bit	Bit Name	Description
0x1B	7	Disable SPI control of XTAL tuning capacitance	Disables functionality of Register 0x1B[5:0]. 0 = tuning capacitance defined by Register 0x1B[5:0]. 1 = the device automatically selects XTAL tuning capacitance (default).
	6	Unused	When programming this register write a Logic 0 to this bit.
	[5:0]	XTAL tuning capacitor control	Capacitance value coded as inverted binary (0.25 pF per bit); that is, 111111 is 0 pF, 111110 is 0.25 pF, and so on. The default value, 000000, is 15.75 pF. The XTAL tuning capacitor bits are ineffective unless Register 0x1B[7] = 0.
0x1C	[7:0]	Unused	Unused.
0x1D	[7:0]	Unused	Unused.
0x1E	[7:0]	Unused	Unused.

REFA Frequency Control (Register 0x1F to Register 0x22)

Table 34.

Address	Bit	Bit Name	Description
0x1F	[7:0]	REFA divider (R_A)	Bits[13:6] of the 14-bit REFA divider.
0x20	[7:2]	REFA divider (R_A)	Bits[5:0] of the 14-bit REFA divider (default: R_A = 2048 decimal). The REFA divider bits are ineffective unless Register 0x20[1] = 1.
	1	Enable SPI control of R_A	Enables SPI port control of the REFA divider value (R_A). 0 = The A[3:0] pins define R_A per Table 14 (default). 1 = The 14-bit value in the REFA divider register defines R_A .
	0	Unused	Unused.
0x21	7	Enable SPI control of x_{2A}	Enables SPI control of the REFA 2x frequency multiplier (x_{2A}) per 0x21[6]. 0 = the device automatically selects x_{2A} per Table 14 (default). 1 = Register 0x21[6] controls the selection of x_{2A} .
	6	Select x_{2A}	Selects x_{2A} . 0 = bypass x_{2A} (default). 1 = select x_{2A} . This bit is ineffective unless Register 0x21[7] = 1.
	5	Enable SPI control of $/5_A$	Enables SPI control of the $/5_A$ prescaler per 0x21[4]. 0 = the device automatically selects $/5_A$ per Table 14 (default). 1 = Register 0x21[4] controls the selection of $/5_A$.
	4	Select $/5_A$	Selects $/5_A$. 0 = bypass $/5_A$ (default). 1 = select $/5_A$. This bit is ineffective unless Register 0x21[5] = 1.
	[3:0]	Unused	Unused.
0x22	[7:0]	Unused	Unused.

REFB Frequency Control (Register 0x23 to Register 0x26)

Table 35.

Address	Bit	Bit Name	Description
0x23	[7:0]	REFB divider (R_B)	Bits[13:6] of the 14-bit REFB divider.
0x24	[7:2]	REFB divider (R_B)	Bits[5:0] of the 14-bit REFB divider (default: $R_B = 4096$ decimal). The REFB divider bits are ineffective unless Register 0x24[1] = 1.
	1	Enable SPI control of R_B	Enables SPI port control of the REFB divider value (R_B). 0 = The A[3:0] pins define R_B per Table 14 (default). 1 = The 14-bit value in the REFB divider register defines R_B .
	0	Unused	Unused.
0x25	7	Enable SPI control of $x2_B$	Enables SPI control of the REFB 2x frequency multiplier ($x2_B$) per Register 0x25[6]. 0 = the device automatically selects $x2_B$ per Table 14 (default). 1 = Register 0x25[6] controls the selection of $x2_B$.
	6	Select $x2_B$	Selects $x2_B$. 0 = bypass $x2_B$ (default). 1 = select $x2_B$. This bit is ineffective unless Register 0x25[7] = 1.
	5	Enable SPI control of $/5_B$	Enables SPI control of the $/5_B$ prescaler per Register 0x25[4]. 0 = the device automatically selects $/5_B$ per Table 14 (default). 1 = Register 0x25[4] controls the selection of $/5_B$.
	4	Select $/5_B$	Selects $/5_B$. 0 = bypass $/5_B$ (default). 1 = select $/5_B$. This bit is ineffective unless Register 0x25[5] = 1.
	[3:0]	Unused	Unused.
0x26	[7:0]	Unused	Unused.

DCXO Frequency and Reference Switchover Control (Register 0x27 to Register 0x31)

Table 36.

Address	Bit	Bit Name	Description
0x27	[7:0]	XO divider (R_{XO})	Bits[13:6] of the 14-bit XO divider.
0x28	[7:2]	XO divider (R_{XO})	Bits[5:0] of the 14-bit XO divider (default: $R_{XO} = 2048$ decimal). The XO divider bits are ineffective unless Register 0x28[1] = 1.
	1	Enable SPI control of R_{XO}	Enables SPI port control of the XO divider value (R_{XO}). 0 = The A[3:0] pins define R_{XO} per Table 14 (default). 1 = The 14-bit value in the XO divider register defines R_{XO} .
	0	Unused	Unused.
0x29	[7:6]	Switchover mode	Selects the switchover operating mode. 00 = revertive switchover (default). 01 = nonrevertive switchover. 10 = selects REFA as the active reference. 11 = selects REFB as the active reference.
	5	REFA diff	Enables the differential input reference function. 0 = normal single-ended operation of REFA and REFB (default). 1 = REFA configured as a differential reference in which the REFA pin functions as one differential input and the REFB/REFA pin functions as the other differential input. In this configuration, the REFB channel and switchover functionality are both unavailable.
	[4:0]	Unused	Unused.
0x2A to 0x31	[7:0]	Unused	Unused.

OUT1 Driver Control (Register 0x32)

Table 37.

Address	Bit	Bit Name	Description
0x32	7	OUT1 drive strength	Controls the output drive capability of the OUT1 driver. 0 = weak. 1 = strong (default).
	6	OUT1 power-down	Controls power-down functionality of the OUT1 driver. 0 = OUT1 active (default). 1 = OUT1 powered down.
	[5:3]	OUT1 mode control	OUT1 driver mode selection. 000 = CMOS, both pins active. 001 = CMOS, positive pin active, negative pin tristate. 010 = CMOS, positive pin tristate, negative pin active. 011 = CMOS, both pins tristate. 100 = LVDS. 101 = LVPECL (default). 110 = not used. 111 = not used.
	[2:1]	OUT1 CMOS polarity	Selects the polarity of the OUT1 pins in CMOS mode. 00 = positive pin is normal polarity and negative pin is inverted polarity (default). 01 = positive pin is normal polarity and negative pin is normal polarity. 10 = positive pin is inverted polarity and negative pin logic is inverted polarity. 11 = positive pin logic is inverted polarity and negative pin is normal polarity. These bits are ineffective unless Bits[5:3] select CMOS mode. See the Output Driver Polarity (CMOS) section for the definition of normal and inverted polarity.
	0	Use Bits[5:3] as source for OUT1 mode control	Controls OUT1 driver functionality. 0 = OUT1 mode determined by the OM[2:0] pins (default). 1 = OUT1 mode defined by Register 0x32[5:3].

Reserved (Register 0x33)

Table 38.

Address	Bit	Bit Name	Description
0x33	[7:0]	Unused	Unused.

AD9553

OUT2 Driver Control (Register 0x34)

Table 39.

Address	Bit	Bit Name	Description
0x34	7	OUT2 drive strength	Controls the output drive capability of the OUT2 driver. 0 = weak. 1 = strong (default).
	6	OUT2 power-down	Controls power-down functionality of the OUT2 driver. 0 = OUT2 active (default). 1 = OUT2 powered down.
	[5:3]	OUT2 mode control	OUT2 driver mode selection. 000 = CMOS, both pins active. 001 = CMOS, positive pin active, negative pin tristate. 010 = CMOS, positive pin tristate, negative pin active. 011 = CMOS, both pins tristate. 100 = LVDS. 101 = LVPECL (default). 110 = not used. 111 = not used.
	[2:1]	OUT2 CMOS polarity	Selects the polarity of the OUT2 pins in CMOS mode. 00 = positive pin is normal polarity and negative pin is inverted polarity (default). 01 = positive pin is normal polarity and negative pin is normal polarity. 10 = positive pin is inverted polarity and negative pin logic is inverted polarity. 11 = positive pin logic is inverted polarity and negative pin is normal polarity. These bits are ineffective unless Bits[5:3] select CMOS mode. See the Output Driver Polarity (CMOS) section for the definition of normal and inverted polarity.
	0	Use Bits[5:3] as source for OUT2 mode control	Controls OUT2 driver functionality. 0 = OUT2 mode determined by the OM[2:0] pins (default). 1 = OUT2 mode defined by Register 0x34[5:3].

OUTLINE DIMENSIONS

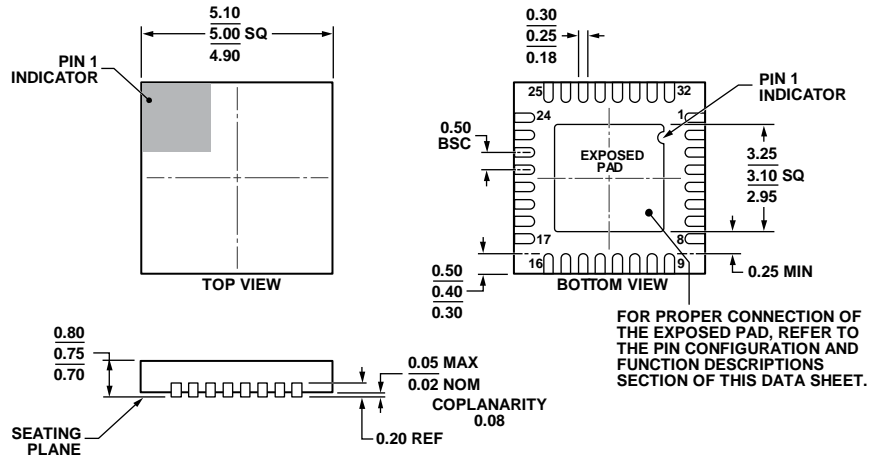

COMPLIANT TO JEDEC STANDARDS MO-220-WHHD.
 Figure 34. 32-Lead Lead Frame Chip Scale Package [LFCSP_WQ]
 5 mm × 5 mm Body, Very, Very Thin Quad
 (CP-32-7)
 Dimensions shown in millimeters

112408-A

ORDERING GUIDE

Model ¹	Temperature Range	Package Description	Package Option
AD9553BCPZ	-40°C to +85°C	32-Lead Lead Frame Chip Scale Package [LFCSP_WQ]	CP-32-7
AD9553BCPZ-REEL7	-40°C to +85°C	32-Lead Lead Frame Chip Scale Package [LFCSP_WQ]	CP-32-7
AD9553/PCBZ		Evaluation Board	

¹ Z = RoHS Compliant Part.

AD9553

NOTES

NOTES

AD9553

NOTES