

### FEATURES

- Low Cost**
- 33 × 17, Fully Differential, Nonblocking Array**
- 3.2 Gb/s per Port NRZ Data Rate**
- Wide Power Supply Range: +3.3 V, -3.3 V**
- Low Power**
  - 425 mA (Outputs Enabled)
  - 35 mA (Outputs Disabled)
- LV PECL and LV ECL Compatible**
- CMOS/TTL-Level Control Inputs: 3 V to 5 V**
- Low Jitter**
- No Heat Sinks Required**
- Drives a Backplane Directly**
- Programmable Output Current**
  - Optimize Termination Impedance
  - User-Controlled Voltage at the Load
  - Minimize Power Dissipation
- Individual Output Disable for Busing and Reducing Power**
- Double Row Latch**
- Buffered Inputs**
- Available in 184-Lead LQFP**

### APPLICATIONS

- High-Speed Serial Backplane Routing to OC-48 with FEC**
- Fiber Optic Network Switching**
- Fiber Channel**
- LVDS**

### PRODUCT DESCRIPTION

AD8151 is a member of the Xstream line of products and is a breakthrough in digital switching, offering a large switch array (33 × 17) on very little power, typically less than 1.5 W. Additionally, it operates at data rates in excess of 3.2 Gb/s per port, making it suitable for Sonet OC-48 with 8b/10b Forward Error Correction (FEC). Further, the pricing of the AD8151 makes it affordable enough to be used for lower data rates as well.

The AD8151's flexible supply voltages allow the user to operate with either PECL or ECL data levels and will operate down to 3.3 V for further power reduction. The control interface is CMOS/TTL compatible (3 V to 5 V).

Its fully differential signal path reduces jitter and crosstalk while allowing the use of smaller single-ended voltage swings.

The AD8151 is offered in a 184-lead LQFP package that operates over the extended commercial temperature range of 0°C to 85°C.

\*Patent Pending.

Xstream is a trademark of Analog Devices, Inc.

### REV. 0

Information furnished by Analog Devices is believed to be accurate and reliable. However, no responsibility is assumed by Analog Devices for its use, nor for any infringements of patents or other rights of third parties that may result from its use. No license is granted by implication or otherwise under any patent or patent rights of Analog Devices.

### FUNCTIONAL BLOCK DIAGRAM

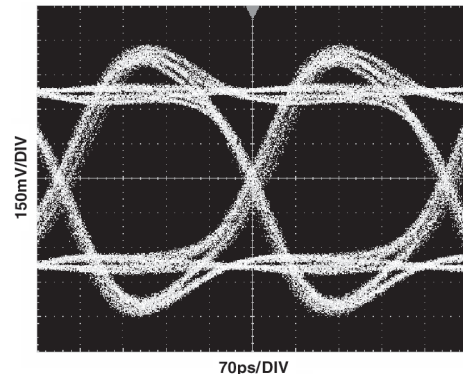
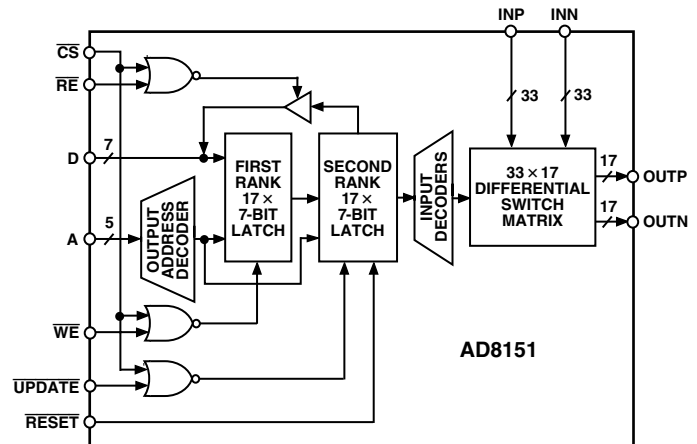

Figure 1. Eye Pattern, 3.2 Gb/s, PRBS 23

# AD8151—SPECIFICATIONS (@ 25°C, V<sub>CC</sub> = 3.3 V to 5 V, V<sub>EE</sub> = 0 V, R<sub>L</sub> = 50 Ω (see TPC 22), I<sub>OUT</sub> = 16 mA, unless otherwise noted.)

Parameter	Conditions	Min	Typ	Max	Unit
<b>DYNAMIC PERFORMANCE</b>					
Max Data Rate/Channel (NRZ)		2.5	3.2		Gb/s
Channel Jitter	Data Rate = 3.2 Gb/s		52		ps p-p
RMS Channel Jitter			8		ps
Propagation Delay	Input to Output		650		ps
Propagation Delay Match			±50	±100	ps
Output Rise/Fall Time	20% to 80%		100		ps
<b>INPUT CHARACTERISTICS</b>					
Input Voltage Swing	Single-Ended	200		1000	mV p-p
Input Bias Current			2		μA
Input Capacitance			2		pF
Input V <sub>IN</sub> High		V <sub>CC</sub> - 1.2		V <sub>CC</sub>	V
Input V <sub>IN</sub> Low		V <sub>CC</sub> - 2.4		V <sub>CC</sub> - 1.4	V
<b>OUTPUT CHARACTERISTICS</b>					
Output Voltage Swing	Differential (See TPC 22)		800		mV p-p
Output Voltage Range		V <sub>CC</sub> - 1.8		V <sub>CC</sub>	V
Output Current		5		25	mA
Output Capacitance			2		pF
Output V <sub>OUT</sub> High		V <sub>CC</sub> - 1.8			V
Output V <sub>OUT</sub> Low				V <sub>CC</sub>	V
<b>POWER SUPPLY</b>					
Operating Range					
PECL, V <sub>CC</sub>	V <sub>EE</sub> = 0 V	3.0		5.25	V
ECL, V <sub>EE</sub>	V <sub>CC</sub> = 0 V	-5.25		-3.0	V
V <sub>DD</sub>		3		5	V
V <sub>SS</sub>			0		V
Quiescent Current			2		mA
V <sub>DD</sub>	All Outputs Enabled, I <sub>OUT</sub> = 16 mA		425		mA
V <sub>EE</sub>	T <sub>MIN</sub> to T <sub>MAX</sub>			450	mA
	All Outputs Disabled		35		mA
<b>THERMAL CHARACTERISTICS</b>					
Operating Temperature Range		0		85	°C
θ <sub>JA</sub>			30		°C/W
<b>LOGIC INPUT CHARACTERISTICS</b>					
Input V <sub>IN</sub> High	V <sub>DD</sub> = 3 V dc to 5 V dc	1.9		V <sub>DD</sub>	V
Input V <sub>IN</sub> Low		0		0.9	V

## ABSOLUTE MAXIMUM RATINGS<sup>1</sup>

### Supply Voltage

$V_{DD} - V_{EE}$ .....	10.5 V
$V_{CC} - V_{EE}$ .....	5.5 V
$V_{DD} - V_{SS}$ .....	5.5 V
$V_{SS} - V_{EE}$ .....	5.5 V
$V_{SS} - V_{CC}$ .....	5.5 V
$V_{DD} - V_{CC}$ .....	5.5 V

### Internal Power Dissipation<sup>2</sup>

AD8151 184-Lead Plastic LQFP (ST) .....	4.2 W
Differential Input Voltage .....	2.0 V
Storage Temperature Range .....	-65°C to +125°C
Lead Temperature Range (Soldering 10 sec) .....	300°C

### NOTES

<sup>1</sup>Stresses above those listed under Absolute Maximum Ratings may cause permanent damage to the device. This is a stress rating only; functional operation of the device at these or any other conditions above those indicated in the operational section of this specification is not implied. Exposure to absolute maximum rating conditions for extended periods may affect device reliability.

<sup>2</sup>Specification is for device in free air ( $T_A = 25^\circ\text{C}$ ):  
184-lead plastic LQFP (ST):  $\theta_{JA} = 30^\circ\text{C}/\text{W}$ .

## MAXIMUM POWER DISSIPATION

The maximum power that can be safely dissipated by the AD8151 is limited by the associated rise in junction temperature. The maximum safe junction temperature for plastic encapsulated devices is determined by the glass transition temperature of the plastic, approximately 150°C. Temporarily exceeding this limit may cause a shift in parametric performance due to a change in the stresses exerted on the die by the package. Exceeding a junction temperature of 175°C for an extended period can result in device failure.

To ensure proper operation, it is necessary to observe the maximum power derating curves shown in Figure 2.

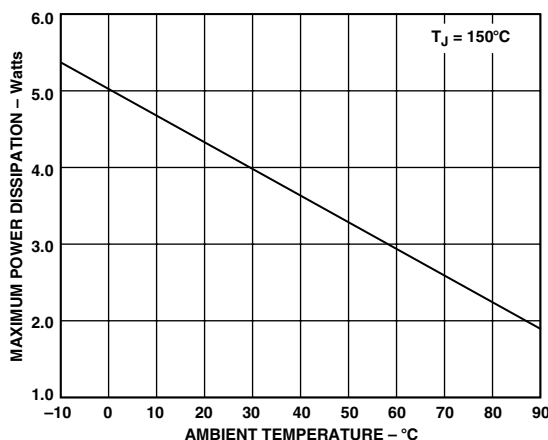

Figure 2. Maximum Power Dissipation vs. Temperature

## ORDERING GUIDE

Model	Temperature Range	Package Description	Package Option
AD8151AST	0°C to 85°C	184-Lead Plastic LQFP (20 mm × 20 mm)	ST-184
AD8151-EVAL		Evaluation Board	

## CAUTION

ESD (electrostatic discharge) sensitive device. Electrostatic charges as high as 4000 V readily accumulate on the human body and test equipment and can discharge without detection. Although the AD8151 features proprietary ESD protection circuitry, permanent damage may occur on devices subjected to high-energy electrostatic discharges. Therefore, proper ESD precautions are recommended to avoid performance degradation or loss of functionality.



## PIN CONFIGURATION

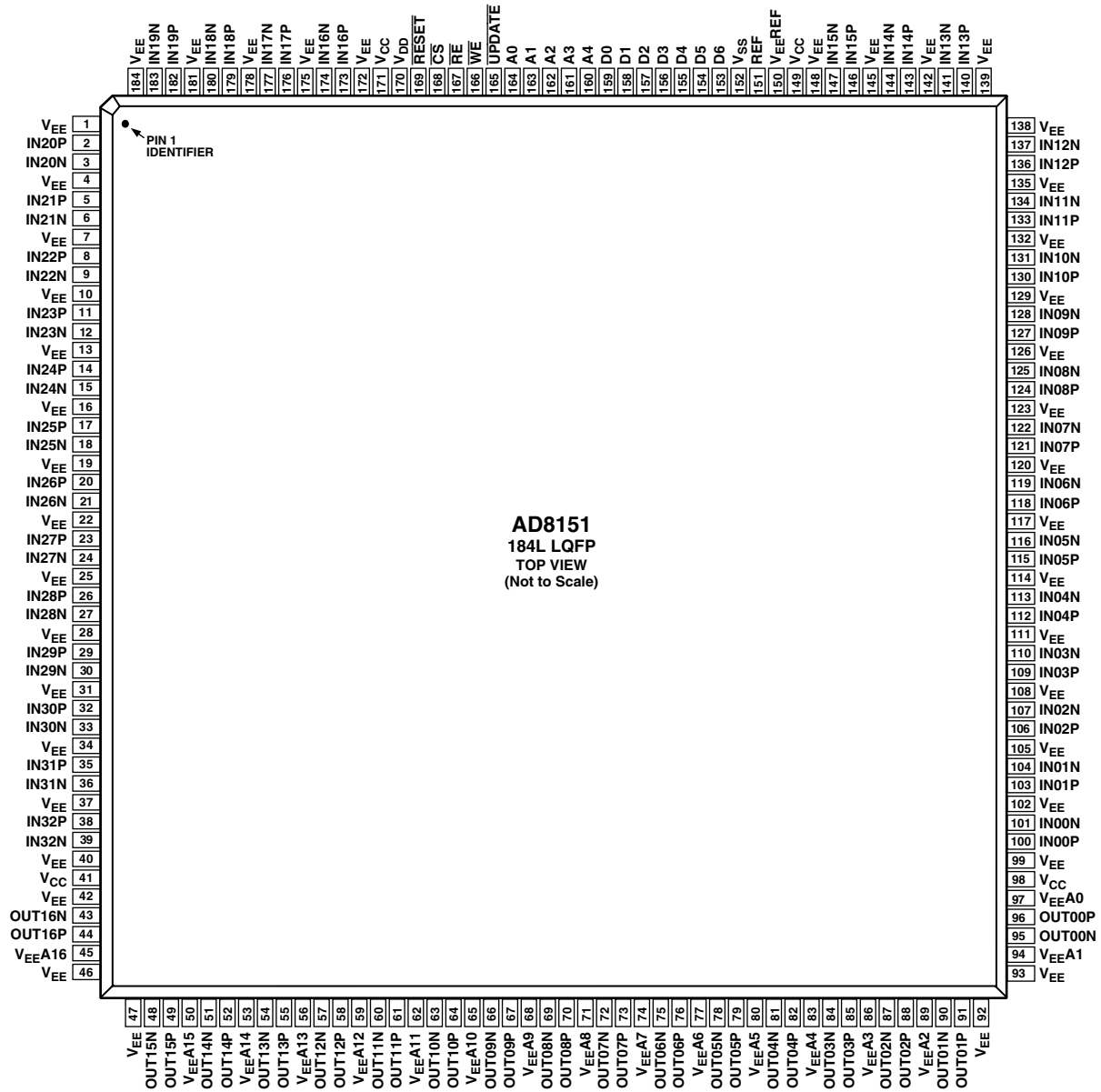

## PIN FUNCTION DESCRIPTIONS

Pin No.	Signal	Type	Description
1, 4, 7, 10, 13, 16, 19, 22, 25, 28, 31, 34, 37, 40, 42, 46, 47, 92, 93, 99, 102, 105, 108, 111, 114, 117, 120, 123, 126, 129, 132, 135, 138, 139, 142, 145, 148, 172, 175, 178, 181, 184	V <sub>EE</sub>	Power Supply	Most Negative PECL Supply (Common with Other Points Labeled V <sub>EE</sub> )
2	IN20P	PECL/ECL	High-Speed Input
3	IN20N	PECL/ECL	High-Speed Input Complement
5	IN21P	PECL/ECL	High-Speed Input
6	IN21N	PECL/ECL	High-Speed Input Complement
8	IN22P	PECL/ECL	High-Speed Input
9	IN22N	PECL/ECL	High-Speed Input Complement
11	IN23P	PECL/ECL	High-Speed Input
12	IN23N	PECL/ECL	High-Speed Input Complement
14	IN24P	PECL/ECL	High-Speed Input
15	IN24N	PECL/ECL	High-Speed Input Complement
17	IN25P	PECL/ECL	High-Speed Input
18	IN25N	PECL/ECL	High-Speed Input Complement
20	IN26P	PECL/ECL	High-Speed Input
21	IN26N	PECL/ECL	High-Speed Input Complement
23	IN27P	PECL/ECL	High-Speed Input
24	IN27N	PECL/ECL	High-Speed Input Complement
26	IN28P	PECL/ECL	High-Speed Input
27	IN28N	PECL/ECL	High-Speed Input Complement
29	IN29P	PECL/ECL	High-Speed Input
30	IN29N	PECL/ECL	High-Speed Input Complement
32	IN30P	PECL/ECL	High-Speed Input
33	IN30N	PECL/ECL	High-Speed Input Complement
35	IN31P	PECL/ECL	High-Speed Input
36	IN31N	PECL/ECL	High-Speed Input Complement
38	IN32P	PECL/ECL	High-Speed Input
39	IN32N	PECL/ECL	High-Speed Input Complement
41, 98, 149, 171	V <sub>CC</sub>	Power Supply	Most Positive PECL Supply (Common with Other Points Labeled V <sub>CC</sub> )
43	OUT16N	PECL/ECL	High-Speed Output Complement
44	OUT16P	PECL/ECL	High-Speed Output
45	V <sub>EE</sub> A16	Power Supply	Most Negative PECL Supply (Unique to This Output)
48	OUT15N	PECL/ECL	High-Speed Output Complement
49	OUT15P	PECL/ECL	High-Speed Output
50	V <sub>EE</sub> A15	Power Supply	Most Negative PECL Supply (Unique to this Output)
51	OUT14N	PECL/ECL	High-Speed Output Complement
52	OUT14P	PECL/ECL	High-Speed Output
53	V <sub>EE</sub> A14	Power Supply	Most Negative PECL Supply (Unique to this Output)
54	OUT13N	PECL/ECL	High-Speed Output Complement
55	OUT13P	PECL/ECL	High-Speed Output
56	V <sub>EE</sub> A13	Power Supply	Most Negative PECL Supply (Unique to this Output)
57	OUT12N	PECL/ECL	High-Speed Output Complement
58	OUT12P	PECL/ECL	High-Speed Output
59	V <sub>EE</sub> A12	Power Supply	Most Negative PECL Supply (Unique to this Output)
60	OUT11N	PECL/ECL	High-Speed Output Complement
61	OUT11P	PECL/ECL	High-Speed Output

# AD8151

Pin No.	Signal	Type	Description
62	V <sub>EE</sub> A11	Power Supply	Most Negative PECL Supply (Unique to this Output)
63	OUT10N	PECL/ECL	High-Speed Output Complement
64	OUT10P	PECL/ECL	High-Speed Output
65	V <sub>EE</sub> A10	Power Supply	Most Negative PECL Supply (Unique to this Output)
66	OUT09N	PECL/ECL	High-Speed Output Complement
67	OUT09P	PECL/ECL	High-Speed Output
68	V <sub>EE</sub> A9	Power Supply	Most Negative PECL Supply (Unique to this Output)
69	OUT08N	PECL/ECL	High-Speed Output Complement
70	OUT08P	PECL/ECL	High-Speed Output
71	V <sub>EE</sub> A8	Power Supply	Most Negative PECL Supply (Unique to this Output)
72	OUT07N	PECL/ECL	High-Speed Output Complement
73	OUT07P	PECL/ECL	High-Speed Output
74	V <sub>EE</sub> A7	Power Supply	Most Negative PECL Supply (Unique to this Output)
75	OUT06N	PECL/ECL	High-Speed Output Complement
76	OUT06P	PECL/ECL	High-Speed Output
77	V <sub>EE</sub> A6	Power Supply	Most Negative PECL Supply (Unique to this Output)
78	OUT05N	PECL/ECL	High-Speed Output Complement
79	OUT05P	PECL/ECL	High-Speed Output
80	V <sub>EE</sub> A5	Power Supply	Most Negative PECL Supply (Unique to this Output)
81	OUT04N	PECL/ECL	High-Speed Output Complement
82	OUT04P	PECL/ECL	High-Speed Output
83	V <sub>EE</sub> A4	Power Supply	Most Negative PECL Supply (Unique to this Output)
84	OUT03N	PECL/ECL	High-Speed Output Complement
85	OUT03P	PECL/ECL	High-Speed Output
86	V <sub>EE</sub> A3	Power Supply	Most Negative PECL Supply (Unique to this Output)
87	OUT02N	PECL/ECL	High-Speed Output Complement
88	OUT02P	PECL/ECL	High-Speed Output
89	V <sub>EE</sub> A2	Power Supply	Most Negative PECL Supply (Unique to this Output)
90	OUT01N	PECL/ECL	High-Speed Output Complement
91	OUT01P	PECL/ECL	High-Speed Output
94	V <sub>EE</sub> A1	Power Supply	Most Negative PECL Supply (Unique to this Output)
95	OUT00N	PECL/ECL	High-Speed Output Complement
96	OUT00P	PECL/ECL	High-Speed Output
97	V <sub>EE</sub> A0	Power Supply	Most Negative PECL Supply (Unique to this Output)
100	IN00P	PECL/ECL	High-Speed Input
101	IN00N	PECL/ECL	High-Speed Input Complement
103	IN01P	PECL/ECL	High-Speed Input
104	IN01N	PECL/ECL	High-Speed Input Complement
106	IN02P	PECL/ECL	High-Speed Input
107	IN02N	PECL/ECL	High-Speed Input Complement
109	IN03P	PECL/ECL	High-Speed Input
110	IN03N	PECL/ECL	High-Speed Input Complement
112	IN04P	PECL/ECL	High-Speed Input
113	IN04N	PECL/ECL	High-Speed Input Complement
115	IN05P	PECL/ECL	High-Speed Input
116	IN05N	PECL/ECL	High-Speed Input Complement
118	IN06P	PECL/ECL	High-Speed Input
119	IN06N	PECL/ECL	High-Speed Input Complement
121	IN07P	PECL/ECL	High-Speed Input
122	IN07N	PECL/ECL	High-Speed Input Complement

Pin No.	Signal	Type	Description
124	IN08P	PECL/ECL	High-Speed Input
125	IN08N	PECL/ECL	High-Speed Input Complement
127	IN09P	PECL/ECL	High-Speed Input
128	IN09N	PECL/ECL	High-Speed Input Complement
130	IN10P	PECL/ECL	High-Speed Input
131	IN10N	PECL/ECL	High-Speed Input Complement
133	IN11P	PECL/ECL	High-Speed Input
134	IN11N	PECL/ECL	High-Speed Input Complement
136	IN12P	PECL/ECL	High-Speed Input
137	IN12N	PECL/ECL	High-Speed Input Complement
140	IN13P	PECL/ECL	High-Speed Input
141	IN13N	PECL/ECL	High-Speed Input Complement
143	IN14P	PECL/ECL	High-Speed Input
144	IN14N	PECL/ECL	High-Speed Input Complement
146	IN15P	PECL/ECL	High-Speed Input
147	IN15N	PECL/ECL	High-Speed Input Complement
150	V <sub>EE</sub> REF	R-Program	Connection Point for Output Logic Pull-Down Programming Resistor (Must be Connected to V <sub>EE</sub> )
151	REF	R-Program	Connection Point for Output Logic Pull-Down Programming Resistor
152	V <sub>SS</sub>	Power Supply	Most Negative Control Logic Supply
153	D6	TTL	Enable/Disable Output
154	D5	TTL	(32) MSB Input Select
155	D4	TTL	(16)
156	D3	TTL	(8)
157	D2	TTL	(4)
158	D1	TTL	(2)
159	D0	TTL	(1) LSB Input Select
160	A4	TTL	(16) MSB Output Select
161	A3	TTL	(8)
162	A2	TTL	(4)
163	A1	TTL	(2)
164	A0	TTL	(1) LSB Output Select
165	$\overline{\text{UPDATE}}$	TTL	Second Rank Program
166	$\overline{\text{WE}}$	TTL	First Rank Program
167	$\overline{\text{RE}}$	TTL	Enable Readback
168	$\overline{\text{CS}}$	TTL	Enable Chip to Accept Programming
169	$\overline{\text{RESET}}$	TTL	Disable All Outputs (Hi-Z)
170	V <sub>DD</sub>	Power Supply	Most Positive Control Logic Supply
173	IN16P	PECL/ECL	High-Speed Input
174	IN16N	PECL/ECL	High-Speed Input Complement
176	IN17P	PECL/ECL	High-Speed Input
177	IN17N	PECL/ECL	High-Speed Input Complement
179	IN18P	PECL/ECL	High-Speed Input
180	IN18N	PECL/ECL	High-Speed Input Complement
182	IN19P	PECL/ECL	High-Speed Input
183	IN19N	PECL/ECL	High-Speed Input Complement

# AD8151—Typical Performance Characteristics

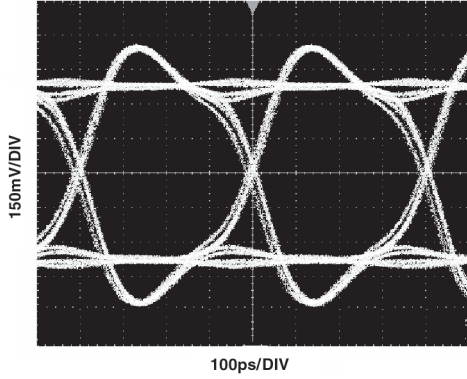

TPC 1. Eye Pattern 2.5 Gb/s, PRBS 23

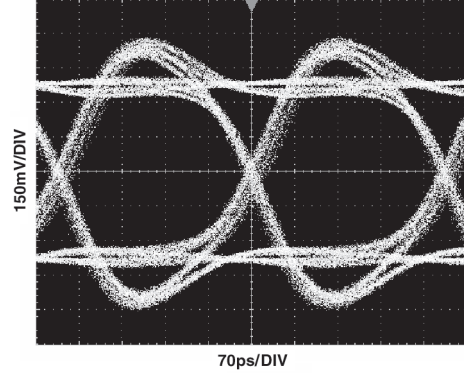

TPC 4. Eye Pattern 3.2 Gb/s, PRBS 23

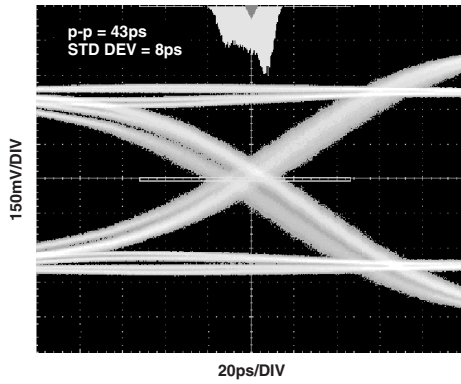

TPC 2. Jitter @ 2.5 Gb/s, PRBS 23

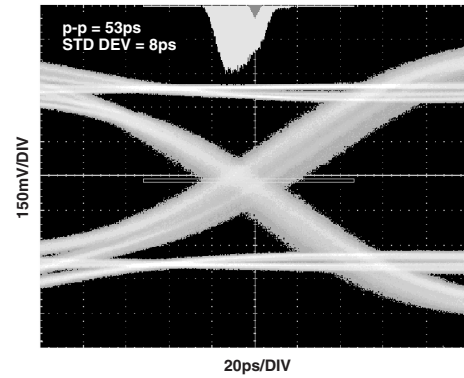

TPC 5. Jitter @ 3.2 Gb/s, PRBS 23

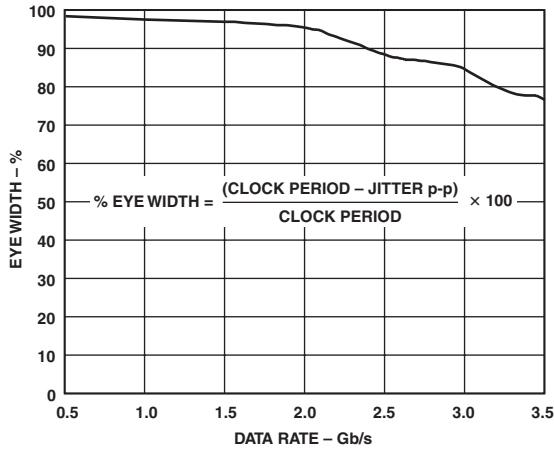

TPC 3. Eye Width vs. Data Rate, PRBS 23

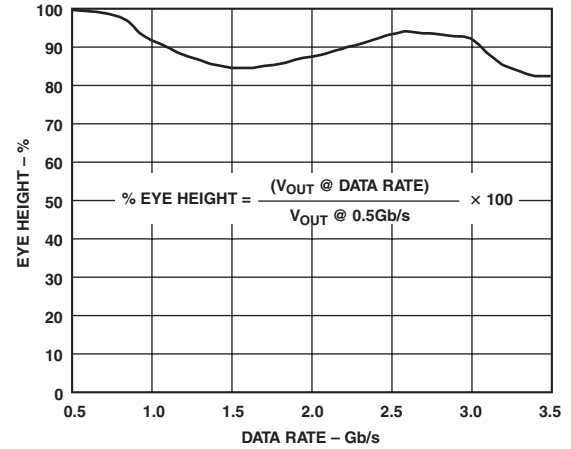

TPC 6. Eye Height vs. Data Rate, PRBS 23



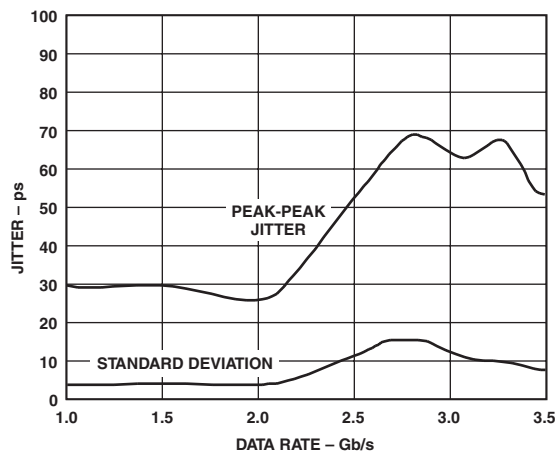

TPC 7. Jitter vs. Data Rate, PRBS 23

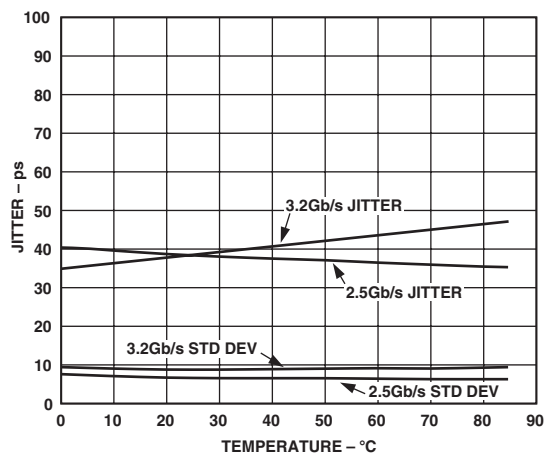

TPC 10. Jitter vs. Temperature, PRBS 23

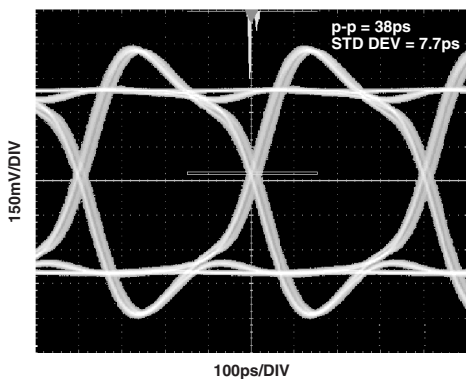

TPC 8. Crosstalk, 2.5 Gb/s, PRBS 23, Attack Signal is OFF

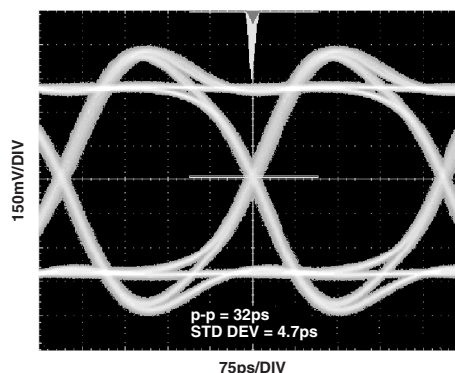

TPC 11. Crosstalk, 3.2 Gb/s, PRBS 23, Attack Signal is OFF

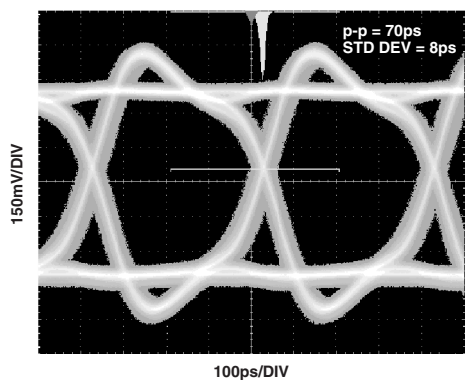

TPC 9. Crosstalk, 2.5 Gb/s, PRBS 23, Attack Signal is ON

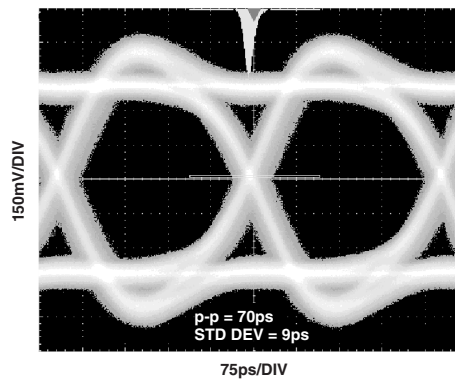

TPC 12. Crosstalk, 3.2 Gb/s, PRBS 23, Attack Signal is ON

# AD8151

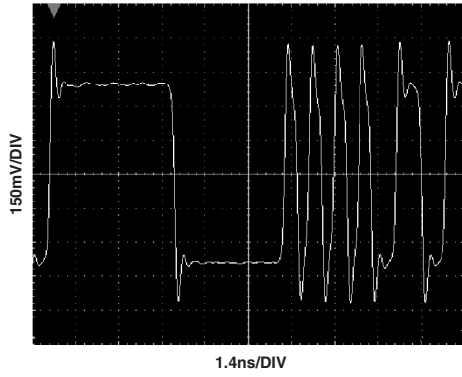

TPC 13. Response, 2.5 Gb/s, 32-Bit Pattern  
1111 1111 0000 0000 0101 0101 0011 0011

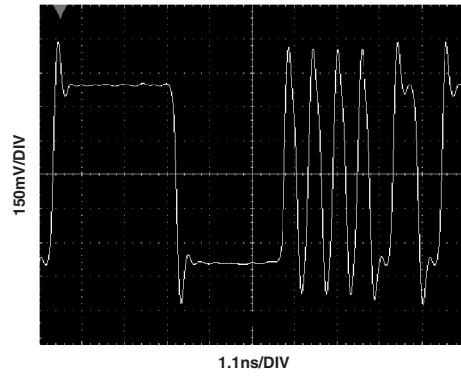

TPC 16. Response, 3.2 Gb/s, 32-Bit Pattern  
1111 1111 0000 0000 0101 0101 0011 0011

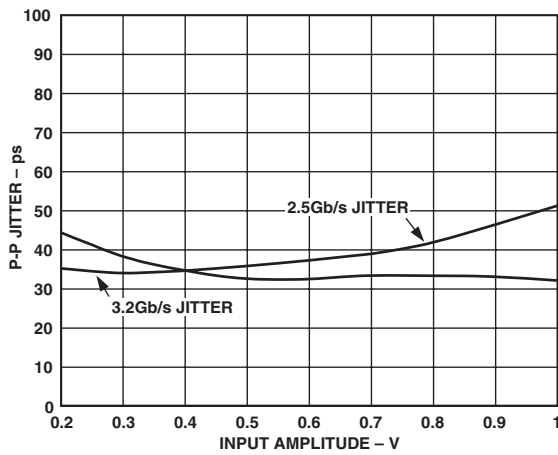

TPC 14. Jitter vs. Single-Ended Input Amplitude, PRBS 23

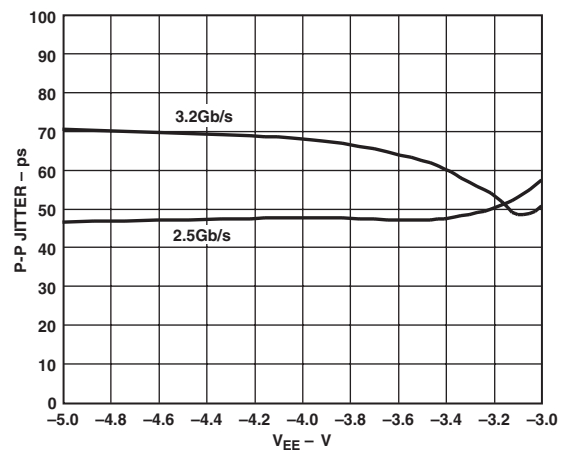

TPC 17. Jitter vs. Supply, PRBS 23

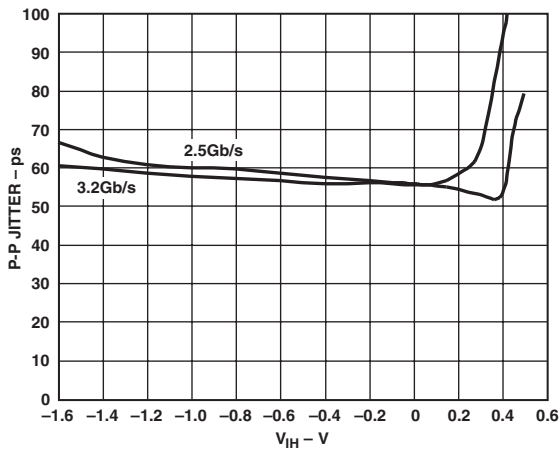

TPC 15. Jitter vs.  $V_{IH}$ , PRBS 23

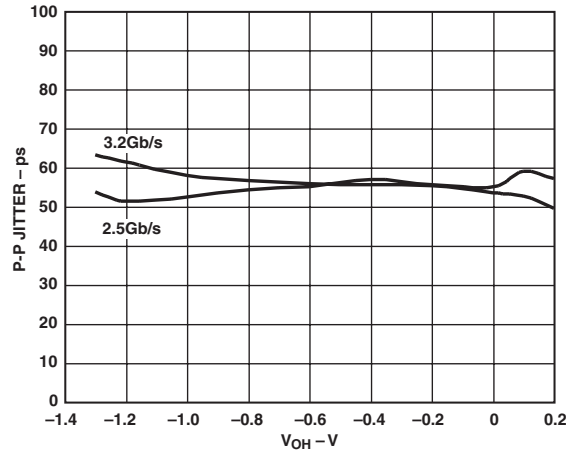

TPC 18. Jitter vs.  $V_{OH}$ , PRBS 23, Output Amplitude = 0.4 V Single-Ended

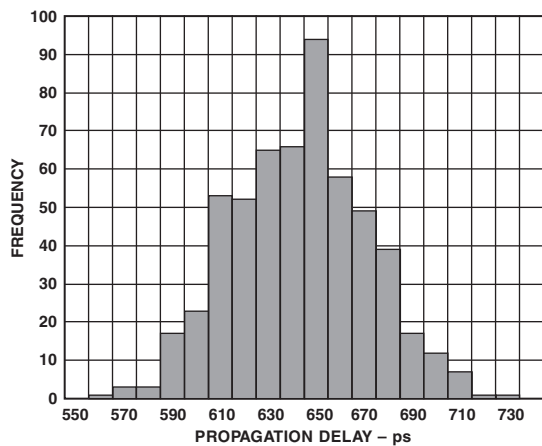

TPC 19. Variation in Channel-to-Channel Delay, All 561 Points

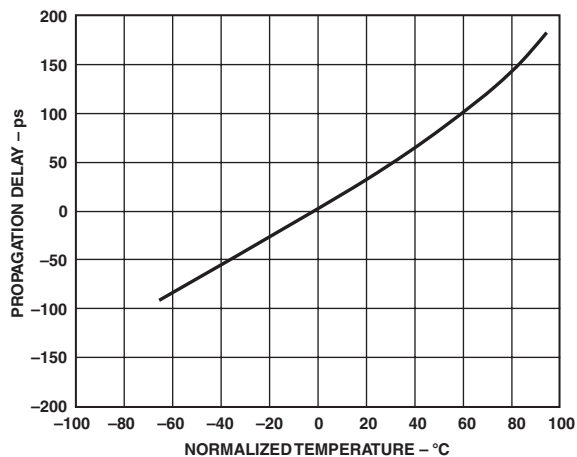

TPC 21. Propagation Delay, Normalized at 25°C vs. Temperature

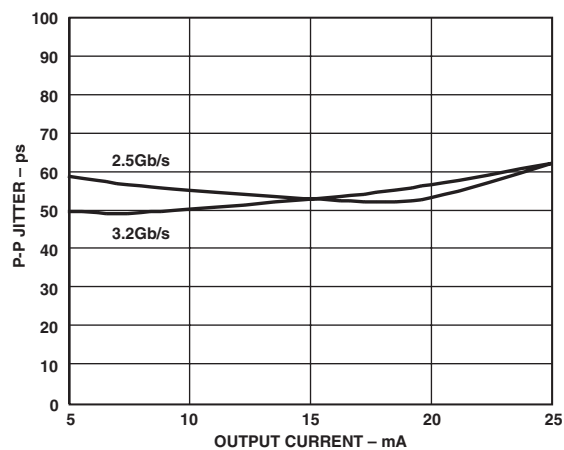

TPC 20. Jitter vs.  $I_{OUT}$ , PRBS 23

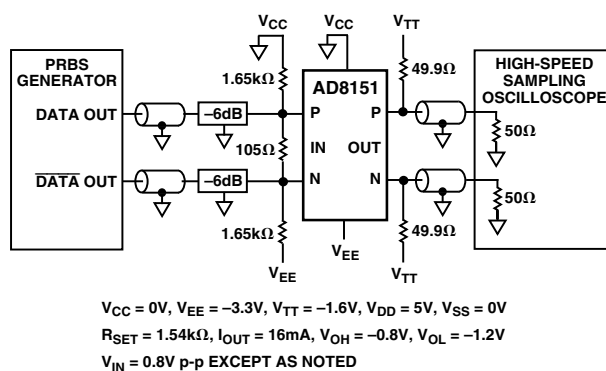

TPC 22. Test Circuit

# AD8151

## Control Interface Truth Tables

The following are truth tables for the control interface.

**Table I. Basic Control Functions**

Control Pins					Function
RESET	CS	WE	RE	UPDATE	
0	X	X	X	X	Global Reset. Reset all second rank enable bits to zero (disable all outputs).
1	1	X	X	X	Control Disable. Ignore all logic (but the signal matrix still functions as programmed). D[6:0] are high-impedance.
1	0	0	X	X	Single Output Preprogram. Write input configuration data from data bus D[6:0] into first rank of latches for the output selected by the output address bus A[4:0].
1	0	X	0	X	Single Output Readback. Readback input configuration data from second rank of latches onto data bus D[6:0] for the single output selected by the output address bus A[4:0].
1	0	X	X	0	Global Update. Copy input configuration data from all 17 first rank latches into second rank of latches, updating signal matrix connections for all outputs.
1	0	0	1	0	Transparent Write and Update. It is possible to write data directly onto rank two. This simplifies logic when synchronous signal matrix updating is not necessary.

**Table II. Address/Data Examples**

Output Address Pins MSB-LSB					Enable Bit	Input Address Pins MSB-LSB						Function	
A4	A3	A2	A1	A0		D6/E	D5	D4	D3	D2	D1		D0
0	0	0	0	0	X	0	0	0	0	0	0	0	Lower Address/Data Range. Connect Output #00 (A[4:0] = 00000) to Input #00 (D[5:0] = 000000).
1	0	0	0	0	X	1	0	0	0	0	0	0	Upper Address/Data Range. Connect Output #16 (A[4:0] = 10000) to Input #32 (D[5:0] = 100000).
<Binary Output Number*>					1	<Binary Input Number>						Enable Output. Connect Selected Output (A[4:0] = 0 to 16) to Designated Input (D[5:0] = 0 to 32) and Enable Output (D6 = 1).	
<Binary Output Number*>					0	X	X	X	X	X	X	X	Disable Output. Disable Specified Output (D6 = 0).
1	0	0	0	1	X	<Binary Input Number>						Broadcast Connection. Connect all 17 outputs to same designated input and set all 17 enable bits to the value of D6. Readback is not possible with the broadcast address.	
1	0	0	1	0	X	1	0	0	0	0	0	1	Reserved. Any address or data code greater or equal to these are reserved for future expansion or factory testing.

\*The binary output number may also be the broadcast connection designator, 10001.

## Control Interface Timing Diagrams

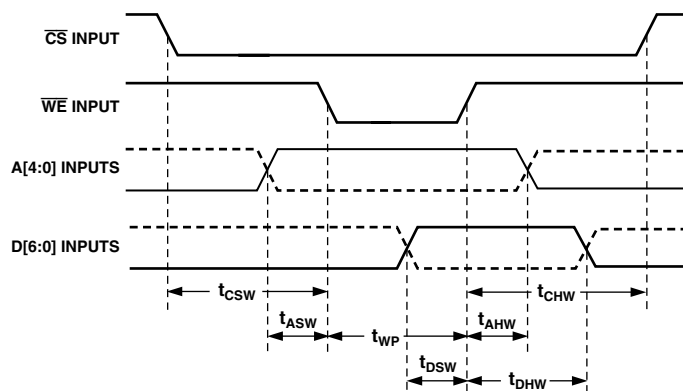

Figure 3. First Rank Write Cycle

Table III. First Rank Write Cycle

Symbol	Parameter		Conditions	Min	Typ	Max	Unit
$t_{CSW}$	Setup Time	Chip Select to Write Enable	$T_A = 25^\circ\text{C}$	0			ns
$t_{ASW}$		Address to Write Enable	$V_{DD} = 5\text{ V}$	0			ns
$t_{DSW}$		Data to Write Enable	$V_{CC} = 3.3\text{ V}$	15			ns
$t_{CHW}$	Hold Time	Chip Select from Write Enable		0			ns
$t_{AHW}$		Address from Write Enable		0			ns
$t_{DHW}$		Data from Write Enable		0			ns
$t_{WP}$	Width of Write Enable Pulse			15			ns

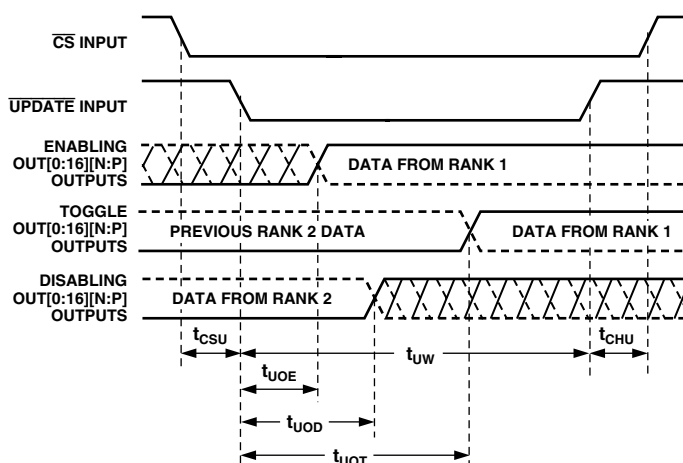

Figure 4. Second Rank Update Cycle

Table IV. Second Rank Update Cycle

Symbol	Parameter		Conditions	Min	Typ	Max	Unit
$t_{CSU}$	Setup Time	Chip Select to Update	$T_A = 25^\circ\text{C}$	0			ns
$t_{CHU}$	Hold Time	Chip Select from Update	$V_{DD} = 5\text{ V}$	0			ns
$t_{UOE}$	Output Enable Times	Update to Output Enable	$V_{CC} = 3.3\text{ V}$		25	40	ns
$t_{UOT}$	Output Toggle Times	Update to Output Reprogram			25	40	ns
$t_{UOD}$	Output Disable Times	Update to Output Disabled			25	30	ns
$t_{UW}$	Width of Update Pulse			15			ns

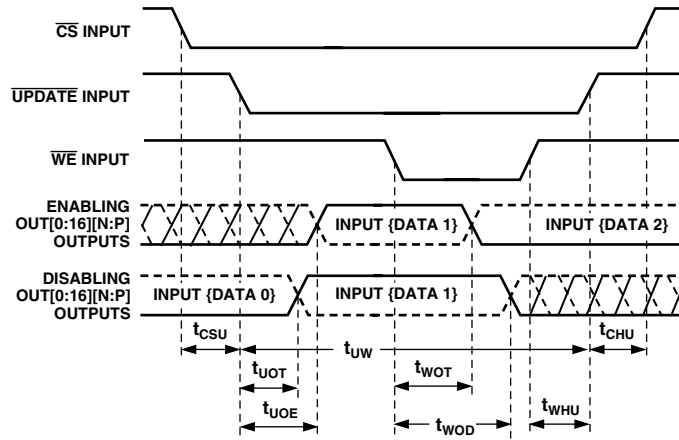

Figure 5. First Rank Write Cycle and Second Rank Update Cycle

Table V. First Rank Write Cycle and Second Rank Update Cycle

Symbol	Parameter		Conditions	Min	Typ	Max	Unit
$t_{CSU}$	Setup Time	Chip Select to Update	$T_A = 25^\circ\text{C}$	0			ns
$t_{CHU}$	Hold Time	Chip Select from Update	$V_{DD} = 5\text{ V}$	0			ns
$t_{UOE}$	Output Enable Times	Update to Output Enable	$V_{CC} = 3.3\text{ V}$		25	40	ns
$t_{WOE}^*$		Write Enable to Output Enable			25	40	ns
$t_{UOT}$	Output Toggle Times	Update to Output Reprogram			25	30	ns
$t_{WOT}$		Write Enable to Output Reprogram			25	30	ns
$t_{UOD}^*$	Output Disable Times	Update to Output Disabled			25	30	ns
$t_{WOD}$		Write Enable to Output Disabled			25	30	ns
$t_{WHU}$	Setup Time	Write Enable to Update		10			ns
$t_{UW}$	Width of Update Pulse			15			ns

\*Not Shown.

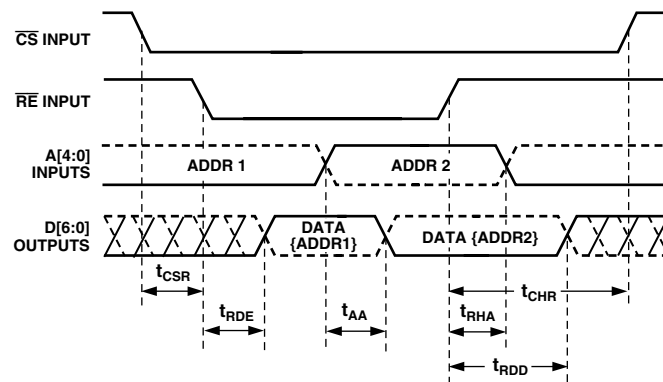

Figure 6. Second Rank Readback Cycle

Table VI. Second Rank Readback Cycle

Symbol	Parameter		Conditions	Min	Typ	Max	Unit
$t_{CSR}$	Setup Time	Chip Select to Read Enable	$T_A = 25^\circ\text{C}$	0			ns
$t_{CHR}$	Hold Time	Chip Select from Read Enable	$V_{DD} = 5\text{ V}$	0			ns
$t_{RHA}$		Address from Read Enable	$V_{CC} = 3.3\text{ V}$	5			ns
$t_{RDE}$	Enable Time	Data from Read Enable	10 k $\Omega$		15		ns
$t_{AA}$	Access Time	Data from Address	20 pF on D[6:0]		15		ns
$t_{RDD}$	Release Time	Data from Read Enable	Bus		15	30	ns

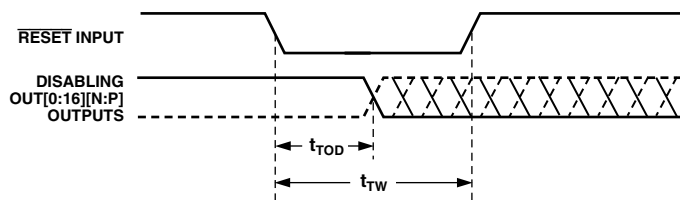

Figure 7. Asynchronous Reset

Table VII. Asynchronous Reset

Symbol	Parameter		Conditions	Min	Typ	Max	Unit
$t_{TOD}$	Disable Time	Output Disable from Reset	$T_A = 25^\circ\text{C}$ $V_{DD} = 5\text{ V}$ $V_{CC} = 3.3\text{ V}$	15	25	30	ns
$t_{TW}$	Width of Reset Pulse						

**Control Interface Programming Example**

The following conservative pattern connects all outputs to input number 7, except output 16 which is connected to input number 32. The vector clock period,  $T_0$  is 15 ns. It is possible to accelerate the execution of this pattern by deleting vectors 1, 4, 7, and 9.

Table VIII. Basic Test Pattern

Vector No.	$\overline{\text{RESET}}$	$\overline{\text{CS}}$	$\overline{\text{WE}}$	$\overline{\text{RE}}$	$\overline{\text{UPDATE}}$	A[4:0]	D[6:0]	Comments
0	0	1	1	1	1	xxxxx	xxxxxxx	Disable All Outputs
1	1	1	1	1	1	xxxxx	xxxxxxx	
2	1	0	1	1	1	10001	1000111	All Outputs to Input #07
3	1	0	0	1	1	10001	1000111	Write to First Rank
4	1	0	1	1	1	10001	1000111	
5	1	0	1	1	1	10000	1100000	Output #16 to Input #32
6	1	0	0	1	1	10000	1100000	Write to First Rank
7	1	0	1	1	1	10000	1100000	
8	1	0	1	1	0	xxxxx	xxxxxxx	Transfer to Second Rank
9	1	0	1	1	1	xxxxx	xxxxxxx	
10	1	1	1	1	1	xxxxx	xxxxxxx	Disable Interface

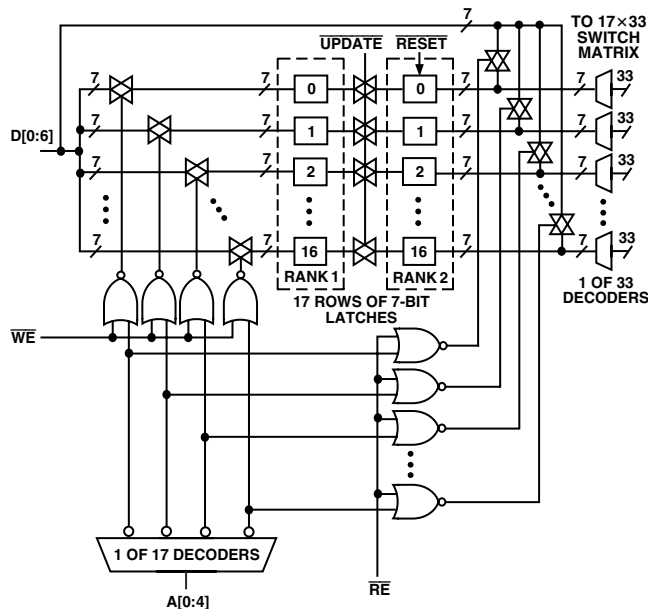

Figure 8. Control Interface (Simplified Schematic)

### AD8151 CONTROL INTERFACE

The AD8151 control interface receives and stores the desired connection matrix for the 33 input and 17 output signal pairs. The interface consists of 17 rows of double-rank 7-bit latches, one row for each output. The 7-bit data word stored in each of these latches indicates to which (if any) of the 33 inputs the output will be connected.

One output at a time can be preprogrammed by addressing the output and writing the desired connection data into the first rank of latches. This process can be repeated until each of the desired output changes has been preprogrammed. All output connections can then be programmed at once by passing the data from the first rank of latches into the second rank. The output connections always reflect the data programmed into the second rank of latches, and do not change until the first rank of data is passed into the second rank.

If necessary for system verification, the data in the second rank of latches can be read back from the control interface.

At any time, a reset pulse can be applied to the control interface to globally reset the appropriate second rank data bits, disabling all 17 signal output pairs. This feature can be used to avoid output bus contention on system start-up. The contents of the first rank remain unchanged.

The control interface pins are connected via logic-level translators. These translators allow programming and readback of the control interface using logic levels different from those in the signal matrix.

In order to facilitate multiple chip address decoding, there is a chip-select pin. All logic signals except the reset pulse are ignored unless the chip select pin is active. The chip select pin disables only the control logic interface, and does not change the operation of the signal matrix. The chip select pin does not power down any of the latches, so any data programmed in the latches is preserved.

All control pins are level-sensitive, not edge-triggered.

### CONTROL PIN DESCRIPTION

#### A[4:0] Inputs

Output address pins. The binary encoded address applied to these five input pins determines which one of the seventeen outputs is being programmed (or being read back). The most significant bit is A4.

#### D[6:0] Inputs/Outputs

Input configuration data pins. In write mode, the binary encoded data applied to pins D[6:0] determine which one of 33 inputs is to be connected to the output specified with the A[4:0] pins. The most significant bit is D5, and the least significant bit is D0. Bit D6 is the enable bit, setting the specified output signal pair to an enabled state if D6 is logic HIGH, or disabled to a high-impedance state if D6 is logic LOW.

In readback mode, pins D[6:0] are low-impedance outputs indicating the data word stored in the second rank for the output specified with the A[4:0] pins. The readback drivers were designed to drive high impedances only, so external drivers connected to the D[6:0] should be disabled during readback mode.

#### $\overline{\text{WE}}$ Input

First Rank Write Enable. Forcing this pin to logic LOW allows the data on pins D[6:0] to be stored in the first rank latch for the output specified by pins A[4:0]. The  $\overline{\text{WE}}$  pin must be returned to a logic HIGH state after a write cycle to avoid overwriting the first rank data.

#### $\overline{\text{UPDATE}}$ Input

Second Rank Write Enable. Forcing this pin to logic LOW allows the data stored in all 17 first rank latches to be transferred to the second rank latches. The signal connection matrix will be reprogrammed when the second rank data is changed. This is a global pin, transferring all 17 rows of data at once. It is not necessary to program the address pins. It should be noted that after initial power-up of the device, the first rank data is undefined. It may be desirable to preprogram all seventeen outputs before performing the first update cycle.

#### $\overline{\text{RE}}$ Input

Second Rank Read-Enable. Forcing this pin to logic LOW enables the output drivers on the bidirectional D[6:0] pins, entering the readback mode of operation. By selecting an output address with the A[4:0] pins and forcing  $\overline{\text{RE}}$  to logic LOW, the 7-bit data stored in the second rank latch for that output address will be written to D[6:0] pins. Data should not be written to the D[6:0] pins externally while in readback mode. The  $\overline{\text{RE}}$  and  $\overline{\text{WE}}$  pins are not exclusive, and may be used at the same time, but data should not be written to the D[6:0] pins from external sources while in readback mode.

#### $\overline{\text{CS}}$ Input

Chip-Select. This pin must be forced to logic LOW in order to program or receive data from the logic interface, with the exception of the  $\overline{\text{RESET}}$  pin, described below. This pin has no effect on the signal pairs and does not alter any of the stored control data.

#### $\overline{\text{RESET}}$ Input

Global Output Disable Pin. Forcing the  $\overline{\text{RESET}}$  pin to logic LOW will reset the enable bit, D6, in all 17 second rank latches, regardless of the state of any other pins. This has the effect of immediately disabling the 17 output signal pairs in the



matrix. It is useful to momentarily hold  $\overline{\text{RESET}}$  at a logic LOW state when powering up the AD8151 in a system that has multiple output signal pairs connected together. Failure to do this may result in several signal outputs contending after power-up. The reset pin is not gated by the state of the chip-select pin,  $\overline{\text{CS}}$ . It should be noted that the  $\overline{\text{RESET}}$  pin does not program the first rank, which will contain undefined data after power-up.

### CONTROL INTERFACE TRANSLATORS

The AD8151 control interface has two supply pins,  $V_{DD}$  and  $V_{SS}$ . The potential between the positive logic supply  $V_{DD}$  and the negative logic supply  $V_{SS}$  must be at least 3 V and no more than 5 V. Regardless of supply, the logic threshold is approximately 1.6 V above  $V_{SS}$ , allowing the interface to be used with most CMOS and TTL logic drivers.

The signal matrix supplies,  $V_{CC}$  and  $V_{EE}$ , can be set independent of the voltage on  $V_{DD}$  and  $V_{SS}$ , with the constraints that  $(V_{DD} - V_{EE}) \leq 10$  V. These constraints will allow operation of the control interface on 3 V or 5 V while the signal matrix is operated on +3.3 V or +5 V PECL, or -3.3 V or -5 V ECL.

### CIRCUIT DESCRIPTION

The AD8151 is a high-speed  $33 \times 17$  differential crosspoint switch designed for data rates up to 3.2 Gb/s per channel. The AD8151 supports PECL-compatible input and output levels when operated from a 5 V supply ( $V_{CC} = 5$  V,  $V_{EE} = \text{GND}$ ) or ECL-compatible levels when operated from a -5 V supply ( $V_{CC} = \text{GND}$ ,  $V_{EE} = -5$  V). To save power, the AD8151 can run from a +3.3 V supply to interface with low-voltage PECL circuits or a -3.3 V supply to interface with low-voltage ECL circuits. The AD8151 utilizes differential current mode outputs with individual disable control, which facilitates busing together the outputs of multiple AD8151s to assemble larger switch arrays. This feature also reduces system crosstalk and can greatly reduce power dissipation in a large switch array. A single external resistor programs the current for all enabled output stages, allowing for user control over output levels with different output termination schemes and transmission line characteristic impedances.

#### High-Speed Data Inputs (INxxP, INxxN)

The AD8151 has 33 pairs of differential voltage-mode inputs. The common-mode input range extends from the positive supply voltage ( $V_{CC}$ ) down to include standard ECL or PECL input levels ( $V_{CC} - 2$  V). The minimum differential input voltage is 200 mV. Unused inputs may be connected directly to any level within the allowed common-mode input range. A simplified schematic of the input circuit is shown in Figure 9.

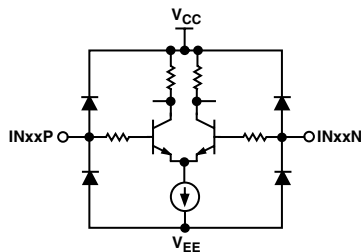

Figure 9. Simplified Input Circuit

In order to maintain signal fidelity at the high data rates supported by the AD8151, the input transmission lines should be terminated as close to the input pins as possible. The preferred input termination structure will depend primarily on the application and the output circuit of the data source. Standard ECL components have open emitter outputs that require pull-down resistors. Three input termination networks suitable for this type of source are shown in Figure 10. The characteristic impedance of the transmission line is shown as  $Z_0$ . The resistors, R1 and R2, in the Thevenin termination are chosen to synthesize a  $V_{TT}$  source with an output resistance of  $Z_0$  and an open-circuit output voltage equal to  $V_{CC} - 2$  V. The load resistors ( $R_L$ ) in the differential termination scheme are needed to bias the emitter followers of the ECL source.

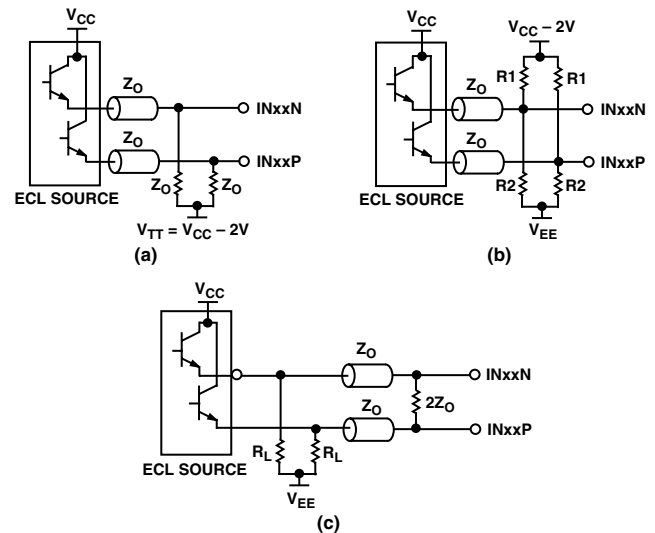

Figure 10. AD8151 Input Termination from ECL/PECL Sources: a) Parallel Termination Using  $V_{TT}$  Supply, b) Thevenin Equivalent Termination, c) Differential Termination

If the AD8151 is driven from a current mode output stage such as another AD8151, the input termination should be chosen to accommodate that type of source, as explained in the following section.

#### High-Speed Data Outputs (OUTyyP, OUTyyN)

The AD8151 has 17 pairs of differential current-mode outputs. The output circuit, shown in Figure 11, is an open-collector NPN current switch with resistor-programmable tail current and output compliance extending from the positive supply voltage ( $V_{CC}$ ) down to standard ECL or PECL output levels ( $V_{CC} - 2$  V). The outputs may be disabled individually to permit outputs from multiple AD8151s to be connected directly. Since the output currents of multiple enabled output stages connected in this way sum, care should be taken to ensure that the output compliance limit is not exceeded at any time; this can be achieved by disabling the active output driver before enabling any inactive driver.

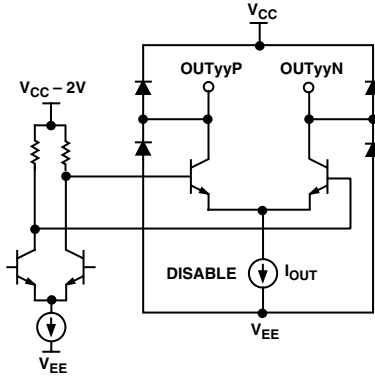

Figure 11. Simplified Output Circuit

To ensure proper operation, all outputs (including unused output) must be pulled high using external pull-up networks to a level within the output compliance range. If outputs from multiple AD8151s are wired together, a single pull-up network may be used for each output bus. The pull-up network should be chosen to keep the output voltage levels within the output compliance range at all times. Recommended pull-up networks to produce PECL/ECL 100 kΩ and 10 kΩ compatible outputs are shown in Figure 12. Alternatively, a separate supply can be used to provide  $V_{COM}$ ; making  $R_{COM}$  and  $D_{COM}$  unnecessary.

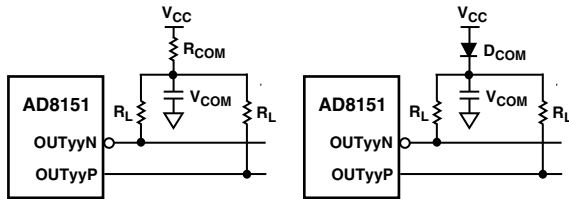

Figure 12. Output Pull-Up Networks: a) ECL 100 kΩ, b) ECL 10 kΩ

The output levels are simply:

$$V_{OH} = V_{COM}$$

$$V_{OL} = V_{COM} - I_{OUT}R_L$$

$$V_{SWING} = V_{OH} - V_{OL} = I_{OUT}R_L$$

$$V_{COM} = V_{CC} - I_{OUT}R_{COM} \text{ (100 k}\Omega \text{ Mode)}$$

$$V_{COM} = V_{CC} - V(D_{COM}) \text{ (10 k}\Omega \text{ Mode)}$$

The common-mode adjustment element ( $R_{COM}$  or  $D_{COM}$ ) may be omitted if the input range of the receiver includes the positive supply voltage. The bypass capacitors reduce common-mode perturbations by providing an ac short from the common nodes ( $V_{COM}$ ) to ground.

When busing together the outputs of multiple AD8151s or when running at high data rates, double termination of its outputs is recommended to mitigate the impact of reflections due to open transmission line stubs and the lumped capacitance of the AD8151 output pins. A possible connection is shown in Figure 13; the bypass capacitors provide an ac short from the common nodes of the termination resistors to ground. To maintain signal fidelity at high data rates, the stubs connecting the output pins to the output transmission lines or load resistors should be as short as possible.

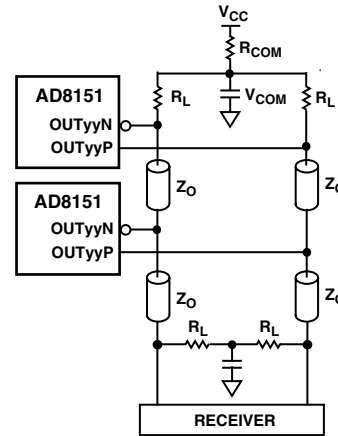

Figure 13. Double Termination of AD8151 Outputs

In this case, the output levels are:

$$V_{OH} = V_{COM} - (1/4) I_{OUT}R_L$$

$$V_{OL} = V_{COM} - (3/4) I_{OUT}R_L$$

$$V_{SWING} = V_{OH} - V_{OL} = (1/2) I_{OUT}R_L$$

### Output Current Set Pin (REF)

A simplified schematic of the reference circuit is shown in Figure 14. A single external resistor connected between the REF pin and  $V_{EE}$  determines the output current for all output stages. This feature allows a choice of pull-up networks and transmission line characteristic impedances while still achieving a nominal output swing of 800 mV. At low data rates, substantial power savings can be achieved by using lower output swings and higher load resistances.

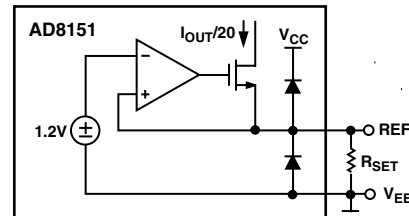

Figure 14. Simplified Reference Circuit

The nominal output current is given by the following expression:

$$I_{OUT} = 20 \left( \frac{1.2 V}{R_{SET}} \right)$$

The minimum set resistor is  $R_{SET,MIN} = 960 \Omega$  resulting in  $I_{OUT,MAX} = 25 \text{ mA}$ . The maximum set resistor is  $R_{SET,MAX} = 4.8 \text{ k}\Omega$  resulting in  $I_{OUT,MIN} = 5 \text{ mA}$ . Nominal 800 mV differential output swing can be achieved in a  $50 \Omega$  load using  $R_{SET} = 1.5 \text{ k}\Omega$  ( $I_{OUT} = 16 \text{ mA}$ ), or in a doubly-terminated  $75 \Omega$  load using  $R_{SET} = 1.13 \text{ k}\Omega$  ( $I_{OUT} = 21.3 \text{ mA}$ ).

To minimize stray capacitance and avoid the pickup of unwanted signals, the external set resistor should be located close to the REF pin. Bypassing the set resistor is not recommended.

## Power Supplies

There are several options for the power supply voltages for the AD8151, as there are two separate sections of the chip that require power supplies. These are the control logic and the high-speed data paths. Depending on the system architecture, the voltage levels of these supplies can vary.

## Logic Supplies

The control (programming) logic is CMOS and is designed to interface with any of the various standard single-ended logic families (CMOS or TTL). Its supply voltage pins are  $V_{DD}$  (Pin 170, logic positive) and  $V_{SS}$  (Pin 152, logic ground). In all cases the logic ground should be connected to the system digital ground.  $V_{DD}$  should be supplied at between 3.3 V to 5 V to match the supply voltage of the logic family that is used to drive the logic inputs.  $V_{DD}$  should be bypassed to ground with a 0.1  $\mu\text{F}$  ceramic capacitor. The absolute maximum voltage from  $V_{DD}$  to  $V_{SS}$  is 5.5 V.

## Data Path Supplies

The data path supplies have more options for their voltage levels. The choices here will affect several other areas, like power dissipation, bypassing, and common mode levels of the inputs and outputs. The more positive voltage supply for the data paths is  $V_{CC}$  (Pins 41, 98, 149 and 171). The more negative supply is  $V_{EE}$ , which appears on many pins that will not be listed here. The maximum allowable voltage across these supplies is 5.5 V.

The first choice in the data path power supplies is to decide whether to run the device as ECL (Emitter-Coupled Logic) or PECL (Positive ECL). For ECL operation,  $V_{CC}$  will be at ground potential, while  $V_{EE}$  will be at a negative supply between  $-3.3$  V to  $-5$  V. This will make the common-mode voltage of the inputs and outputs at a negative voltage, see Figure 15.

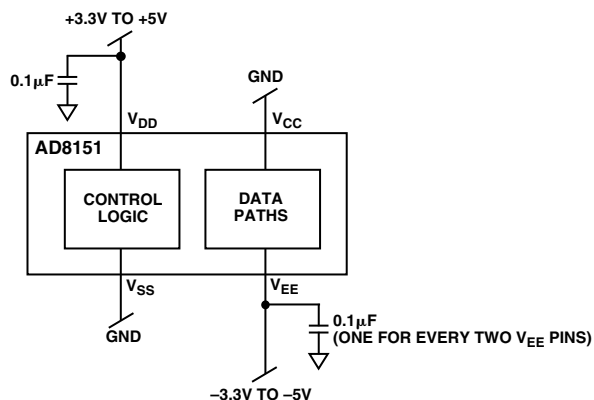

Figure 15. Power Supplies and Bypassing for ECL Operation

If the data paths are to be dc-coupled to other ECL logic devices that run with ground as the most positive supply and a negative voltage for  $V_{EE}$ , then this is the proper way to run. However, if

the part is to be ac-coupled, it is not necessary to have the input/output common mode at the same level as the other system circuits, but it will probably be more convenient to use the same supply rails for all devices.

For PECL operation,  $V_{EE}$  will be at ground potential and  $V_{CC}$  will be a positive voltage from 3.3 V to 5 V. Thus, the common mode of the inputs and outputs will be at a positive voltage. These can then be dc-coupled to other PECL operated devices. If the data paths are ac-coupled, then the common-mode levels do not matter, see Figure 16.

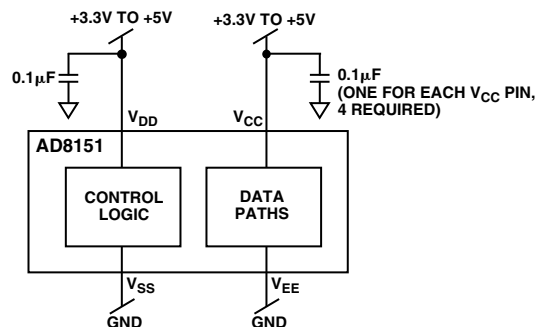

Figure 16. Power Supplies and Bypassing for PECL Operation

## POWER DISSIPATION

For analysis, the power dissipation of the AD8151 can be divided into three separate parts. These are the control logic, the data path circuits and the (ECL or PECL) outputs, which are part of the data path circuits, but can be dealt with separately. The first of these, the control logic, is CMOS technology and does not dissipate a significant amount of power. This power will, of course, be greater when the logic supply is 5 V rather than 3 V, but overall it is not a significant amount of power and can be ignored for thermal analysis.

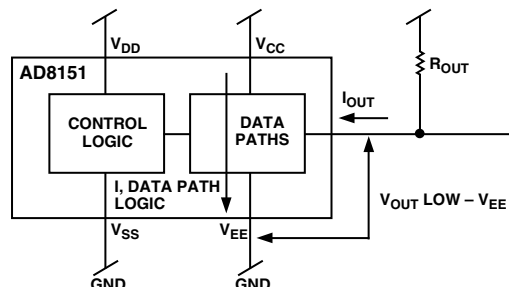

Figure 17. Major Power Consumption Paths

The data path circuits operate between the supplies  $V_{CC}$  and  $V_{EE}$ . As described in the power supply section, this voltage can range from 3.3 V to 5 V. The current consumed by this section will be constant, so operating at a lower voltage can save about 35 percent in power dissipation.

# AD8151

The power dissipated in the data path outputs is affected by several factors. The first is whether the outputs are enabled or disabled. The worst case occurs when all of the outputs are enabled.

The current consumed by the data path logic can be approximated by:

$$I_{CC} = 35 \text{ mA} + [4.5 \text{ mA} + (I_{OUT}/20 \text{ mA} \times 3 \text{ mA})] \\ \times (\# \text{ of outputs enabled})$$

This says that there will always be a minimum of 35 mA flowing.  $I_{CC}$  will increase by a factor that is proportional to both the number of enabled outputs and the programmed output current.

The power dissipated in this circuit section will simply be the voltage of this section ( $V_{CC} - V_{EE}$ ) times the current. For a worst case, assume that  $V_{CC} - V_{EE}$  is 5.0 V, all outputs are enabled and the programmed output current is 25 mA. The power dissipated by the data path logic will be:

$$P = 5.0 \text{ V} \{35 \text{ mA} + [4.5 \text{ mA} + (25 \text{ mA}/20 \text{ mA} \times 3 \text{ mA})] \\ \times 17\} = 876 \text{ mW}$$

The power dissipated by the output current depends on several factors. These are the programmed output current, the voltage drop from a logic low output to  $V_{EE}$  and the number of enabled outputs. A simplifying assumption is that one of each (enabled) differential output pair will be low and draw the full output current (and dissipate most of the power for that output), while the complementary output of the pair will be high and draw insignificant current. Thus, its power dissipation of the high output can be ignored and the output power dissipation for each output can be assumed to occur in a single static low output that sinks the full output-programmed current.

The voltage across which this current flows can also vary, depending on the output circuit design and the supplies that are used for the data path circuitry. In general, however, there will be a voltage difference between a logic low signal and  $V_{EE}$ . This is the drop across which the output current flows. For a worst case, this voltage can be as high as 3.5 V. Thus, for all outputs enabled and the programmed output current set to 25 mA, the power dissipated by the outputs:

$$P = 3.5 \text{ V} (25 \text{ mA}) \times 17 = 1.49 \text{ W}$$

## HEAT SINKING

Depending on several factors in its operation, the AD8151 can dissipate upwards of 2 W or more. The part is designed to operate without the need for an explicit external heatsink. However, the package design offers enhanced heat removal via some of the package pins to the PC board traces.

The  $V_{EE}$  pins on the input sides of the package (Pins 1 to 46 and Pins 93 to 138) have “finger” extensions inside the package that connect to the “paddle” upon which the IC chip is mounted. These pins provide a lower thermal resistance from the IC to the  $V_{EE}$  pins than other pins that just have a bond wire. As a result these pins can be used to enhance the heat removal process from the IC to the circuit board and ultimately to the ambient.

The  $V_{EE}$  pins described above should be connected to a large area of circuit board trace material in order to take most advantage their lower thermal resistance. If there is a large area available on an inner layer that is at  $V_{EE}$  potential, then vias can be provided from the package pin traces to this layer. There should be no thermal-relief pattern when connecting the vias to the inner layers for these  $V_{EE}$  pins. Additional vias in parallel and close to

the pin leads can provide an even lower thermal resistive path. If possible to use, 2 oz. copper foil will provide better heat removal than 1 oz.

The AD8151 package has a specified thermal impedance  $\theta_{JA}$  of 30°C/W. This is the worst case, still-air value that can be expected when the circuit board does not significantly enhance the heat removal from the package. By using the concept described above or by using forced-air circulation, the thermal impedance can be lowered.

For an extreme worst case analysis, the junction rise above the ambient can be calculated assuming 2 W of power dissipation and  $\theta_{JA}$  of 30°C/W to yield a 60°C rise above the ambient. There are many techniques described above that can mitigate this situation. Most actual circuits will not result in this high a rise of the junction temperature above the ambient.

## APPLICATIONS

### AD8151 INPUT AND OUTPUT BUSING

Although the AD8151 is a digital part, in any application that runs at high speed, analog design details will have to be given very careful consideration. At high data rates, the design of the signal channels will have a strong influence on the data integrity and its associated jitter and ultimately bit error rate (BER).

While it might be considered very helpful to have a suggested circuit board layout for any particular system configuration, this is not something that can be practically realized. Systems come in all shapes, sizes, speeds, performance criteria and cost constraints. Therefore, some general design guidelines will be presented that can be used for all systems and judiciously modified where appropriate.

High-speed signals travel best, i.e. maintain their integrity, when they are carried by a uniform transmission line that is properly terminated at either end. Any abrupt mismatches in impedance or improper termination will create reflections that will add to or subtract from parts of the desired signal. Small amounts of this effect are unavoidable, but too much will distort the signal to the point that the channel BER will increase. It is difficult to fully quantify these effects, because they are influenced by many factors in the overall system design.

A constant-impedance transmission line is characterized by having a uniform cross-section profile over its entire length. In particular, there should be no “stubs,” which are branches that intersect the main run of the transmission line. These can have an electrical “appearance” that is approximated by a lumped element, such as a capacitor, or if long enough, as another transmission line. To the extent that stubs are unavoidable in a design, their effect can be minimized by making them as short as possible and as high an impedance as possible.

Figure 13 shows a differential transmission line that connects two differential outputs from AD8151s to a generic receiver. A more generalized system can have more outputs bused, and more receivers on the same bus, but all the same concepts apply. The inputs of the AD8151 can also be considered as a receiver. The transmission lines that bus all of the devices together are shown with terminations at each end.

The individual outputs of the AD8151 are stubs that intersect the main transmission line. Ideally, their current-source outputs would be infinite impedance, and they would have no effect on signals that propagate along the transmission line. In reality, each

external pin of the AD8151 projects into the package, and has a bond wire connected to the chip inside. On-chip wiring then connects to the collectors of the output transistors and to ESD protection diodes.

Unlike some other high-speed digital components, the AD8151 does not have on-chip terminations. While this location would be closer to the actual end of the transmission line for some architectures, this concept can limit system design options. In particular, it is not possible to bus more than two inputs or outputs on the same transmission line and it is also not possible to change the value of these terminations to use for different impedance transmission lines. The AD8151, with the added ability to disable its outputs, is much more versatile in these types of architectures.

If the external traces are kept to a bare minimum, then the output will present a mostly lumped capacitive load of about 2 pF. A single stub of 2 pF will not seriously adversely affect signal integrity for most transmission lines, but the more of these stubs, the more adverse their influence will be.

One way to mitigate this effect is to locally reduce the capacitance of the main transmission line near the point of stub intersection. Some practical means for doing this are to narrow the PC board traces in the region of the stub and/or to remove some of the ground plane(s) near this intersection. The effect of these techniques will locally lower the capacitance of the main transmission line at these points, while the added capacitance of the AD8151 outputs will “compensate” for this reduction in capacitance. The overall intent is to create as uniform a transmission line as possible.

In selecting the location of the termination resistors it is important to keep in mind that, as their name implies, they should be placed at either end of the line. There should be no or minimal projection of the transmission line beyond the point where the termination resistors connect to it.

## EVALUATION BOARD

An evaluation board has been designed and is available to rapidly test the main features of the AD8151. This board lets the user analyze the analog performance of the AD8151 channels and easily control the configuration of the board by a standard PC.

The board has limited numbers of differential input/output pairs. Each differential pair of microstrip is connected to either top-mount or side-launch SMA connectors. The top-mount SMA connectors are drilled and stubbed for superior performance. The FR4 type board contains a total of nine outputs (all even numbered outputs) and 20 inputs (numbers 0, 2, 4, 6, 8, 10, 12, 13, 14, 15, 16, 17, 18, 20, 22, 24, 26, 28, 30, 32). It is important to note that the shells of the SMA connectors are attached to V<sub>CC</sub>. This makes only ECL or negative level swings possible during testing.

### Power Supplies

The AD8151 is designed to work with standard ECL logic levels. This means that V<sub>CC</sub> is at ground and V<sub>EE</sub> is at a negative supply. The shells of the I/O SMA connectors are at V<sub>CC</sub> potential. Thus, when operating in the standard ECL configuration, test equipment can be directly connected to the board, as the test equipment will have its connector “shells” at ground potential also.

Operating in PECL mode requires V<sub>CC</sub> to be at a positive voltage, while V<sub>EE</sub> is at ground. Since this would make the shells of the I/O connectors at a positive voltage, it can cause problems when directly connecting to test equipment. Some equipment, such as battery-operated oscilloscopes, can be “floated” from ground, but care should be taken with line-powered equipment to avoid creating a dangerous situation. Refer to the manual of the test equipment that is being used.

The voltage difference from V<sub>CC</sub> to V<sub>EE</sub> can range from 3 V to 5 V. Power savings can be realized by operating at a lower voltage without any compromise in performance.

A separate connection is provided for V<sub>TT</sub>, the termination potential of the outputs. This can be at a voltage as high as V<sub>CC</sub>, but power savings can be realized if V<sub>TT</sub> is at a voltage that is somewhat lower. Please consult elsewhere in the data sheet for the specification for the limits of the V<sub>TT</sub> supply.

As a practical matter, current on the evaluation board will flow from the V<sub>TT</sub> supply, through the termination resistors, into the multiple outputs of the AD8151, and on to the V<sub>EE</sub> supply. When running in ECL mode, V<sub>TT</sub> will want to be at a negative supply.

Most power supplies will not allow their ground connection to V<sub>CC</sub> and then the negative supply to V<sub>TT</sub>. This will require them to source current from their negative supply, which wants to flow to the more-negative V<sub>EE</sub>. This current will not then return to the ground terminal of the V<sub>TT</sub> supply. Thus, V<sub>TT</sub> should be referenced to V<sub>EE</sub> when running in ECL mode or a true bipolar supply should be used.

The digital supply is provided to the AD8151 by the V<sub>DD</sub> and V<sub>SS</sub> pins. V<sub>SS</sub> should always be at ground potential to make it compatible with standard CMOS or TTL logic. V<sub>DD</sub> can range from 3 V to 5 V, and should be matched to the supply voltage of the logic used to control the AD8151. However, since PCs use 5 V logic on their parallel port, V<sub>DD</sub> should be at 5 V when using a PC to program the AD8151.

### Bypassing

Most of the board’s bypass capacitors are opposite the DUT on the solder side, connected between V<sub>CC</sub> and V<sub>EE</sub>. This is where they will be most effective. These capacitors are 0.01 μF ceramic chip capacitors for low inductance. There are additional higher value capacitors elsewhere on the board for bypassing at lower frequencies. The location of these is not as critical.

### Input and Output Considerations

Each input contains a 100 Ω differential termination. Although the differential termination eases board layout due to its compact nature, it can cause problems with the driving generator. A typical pulse or pattern generator wants to see 50 Ω to ground (or to –2 V in some cases). High speed probing of the input showed if this type of termination is not present then input amplitudes could be slightly off. Even more affected can be the dc input levels. Depending on the generator used, these levels can be off as much as 800 mV in either direction. A correction for this problem is to attach a 6 dB attenuator to each P and N input. Because the AD8151 has a large common-mode voltage range on its input stage, it will not be significantly affected by dc level errors.

# AD8151

On this evaluation board all unused inputs are tied to  $V_{CC}$  (GND). All outputs, whether brought out to connectors or not, are tied to  $V_{TT}$  through a 49.9  $\Omega$  resistor. The AD8151 device is on the component side of the board, while input terminations and output back terminations are on the circuit side. The input signals from the circuit side transit through via holes to the DUT's pads. The component-side output signals connect to via holes and to circuit-side 49.9  $\Omega$  termination resistors.

## Board Construction

For this board FR4 material was chosen over more exotic board materials. Tests showed exotic materials to be unnecessary. This is a 4-layer board. Power is bused on both external and internal layers. Test structures showed microstrip performance to be unaffected by the dc bias levels on the plane beneath it.

The manufacturing process should produce a controlled-impedance board. The board stack consists of a 5-mil-thick layer between external and internal layers. This allows the use of an 8-mil-wide microstrip trace running from SMA connector to the DUT's pads. The narrow trace avoids the need to neck down the trace width as DUT's pads are approached and it helps to control the microstrip trace impedance. The thin 5-mil dielectric also helps to control crosstalk by way of confining the electromagnetic fields more between the trace and the plane below.

## Configuration Programming

The board is configurable by one of two methods. For ease of use, custom software is provided that controls the AD8151 programming via the parallel port of a PC. This requires a user-supplied standard printer cable that has a DB-25 connector at one end (parallel- or printer-port interface) and a Centronix-type connector at the other that connects to P2 of the AD8151 evaluation board. The programming with this scheme is done in a serial fashion, so it is not the fastest way to configure the AD8151 matrix. However, the user interface makes it very convenient to use this programming method.

If a high-speed programming interface is desired, the AD8151 address and data buses are directly available on P3. The source of the program signals can be a piece of test equipment, like the Tektronix HFS-9000 digital test generator, or some other user-supplied hardware that generates programming signals.

When using the PC interface, the jumper at W1 should be installed and no connections should be made to P3. When using the P3 interface, no jumper is installed at W1. There are locations for termination resistors for the address and data signals if these are necessary.

## Software Installation

The software to operate the AD8151 is provided on two 3.5" floppy disks. The software is installed by inserting Disk 1 into the floppy drive of a PC and running the "setup.exe" program. This will routinely install the software and prompt the user when to change to Disk 2. The setup program will also prompt the user to select the directory for the program.

After running the software, the user will be prompted to identify which (of three) software driver is used with the PC's parallel port. The default is LPT1, which is most commonly used. However, some laptops commonly use the PRN driver. It is also possible that some systems are configured with the LPT2 driver.

If it is not known which driver is used, it is best to select LPT1 and proceed to the next screen. This will show a full array of "buttons" that allows the connection of any input to output of the AD8151. All of the outputs should be in the output "OFF" state right after the program starts running. Any of the active buttons can be selected with a mouse click, which will send out one burst of programming data.

After this, the PC keyboard's left or right arrow keyboard key can be held down to generate a steady stream of programming signals out of the parallel port. The CLOCK test point on the AD8151 evaluation board can be monitored with an oscilloscope for any activity (user-supplied printer cable must be connected). If there is a square-wave present, the proper software driver is selected for the PC's parallel port.

If there is no signal present, another driver should be tried by selecting the Parallel Port menu item under the "File" pull-down menu selection just under the title bar. Select a different software driver and carry out the above test until signal activity is present at the CLOCK test point.

## Software Operation

Any button can be clicked in the matrix to program the input to output connection. This will send the proper programming sequence out the PC parallel port. Since only one input can be programmed to a given output at one time, clicking a button in a horizontal row will cancel the other selection that is already selected in that row. However, any number of outputs can share the same input.

A shortcut for programming all outputs to the same input is to use the broadcast feature. After clicking on the Broadcast Connection button, a screen will appear that will prompt for the user to select which input should be connected to all outputs. The user should type in an integer from 0 to 32 and then click on OK. This will send out the proper program data and return to the main screen with a full column of buttons selected under the chosen input.

The Off column can be used to disable to whichever output one chooses. To disable all outputs, the Global Reset button can be clicked. This will select the full column of OFF buttons.

Two scratch-pad memories (Memory 1 and Memory 2) are provided to conveniently save a particular configuration. However, these registers are erased when the program is terminated. For long-term storage of configurations, the disk-storage memory should be used. The Save and Load selections can be accessed from the "File" pull-down menu under the title bar.

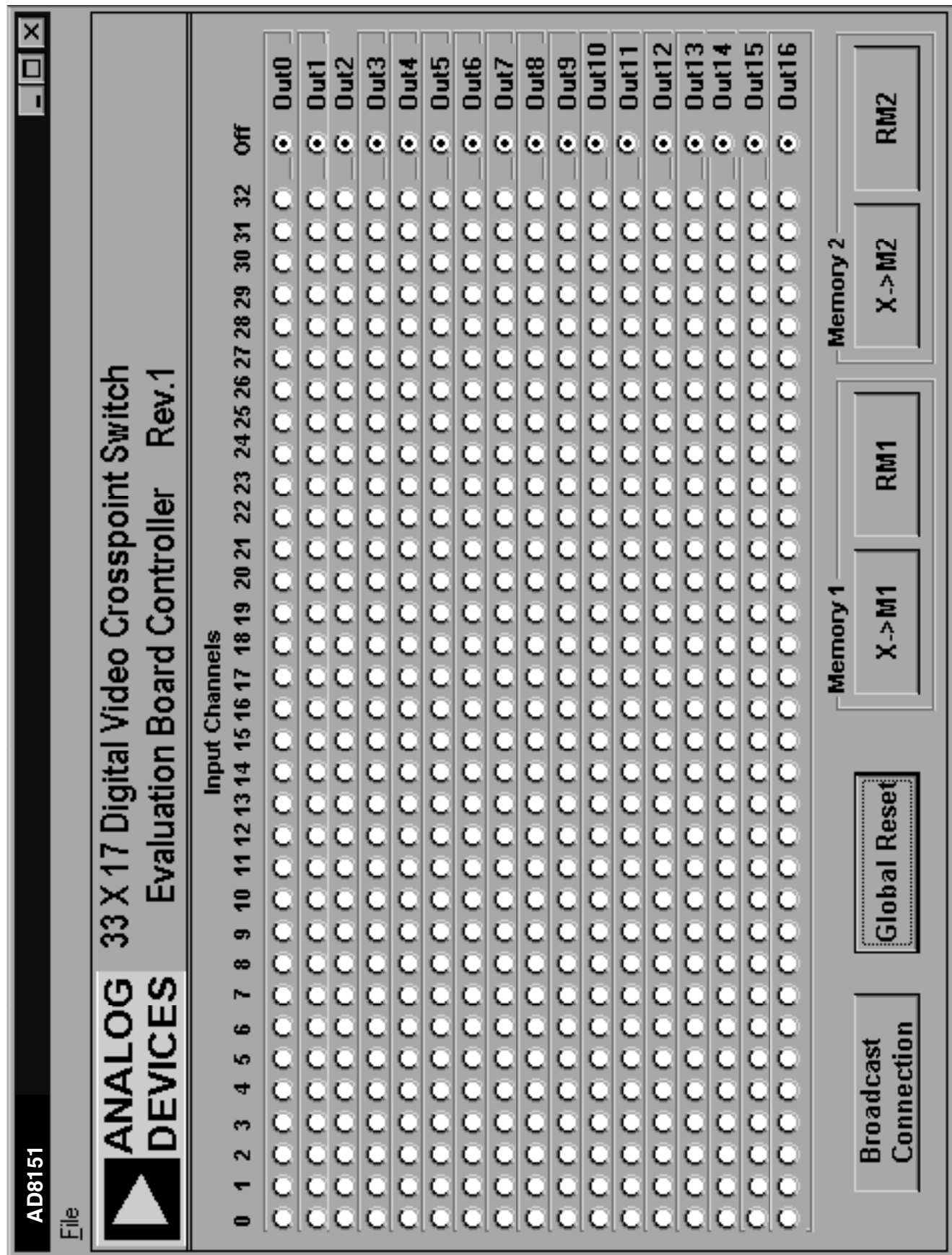

Figure 18. Evaluation Board Controller

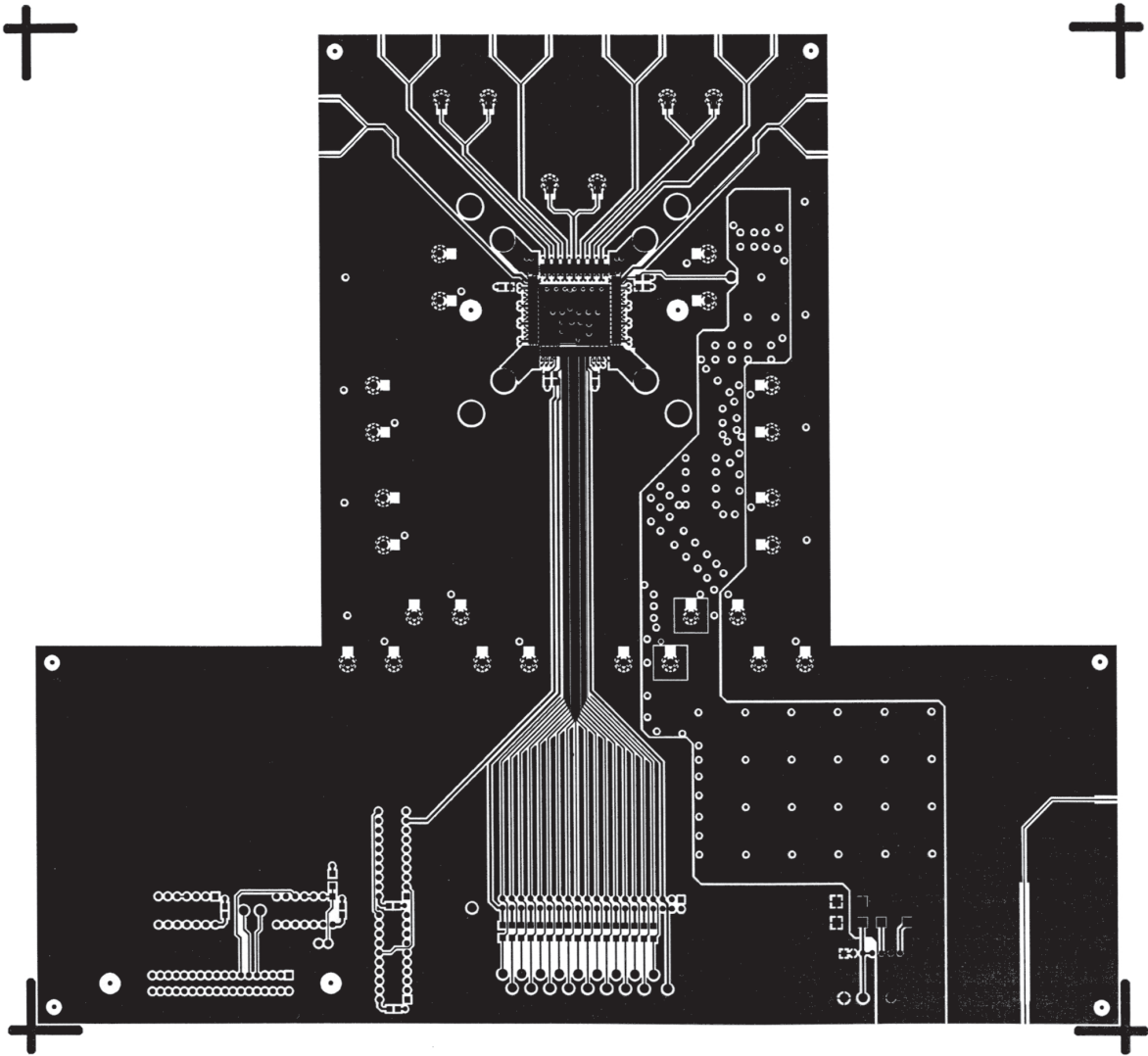

Figure 19. Component Side



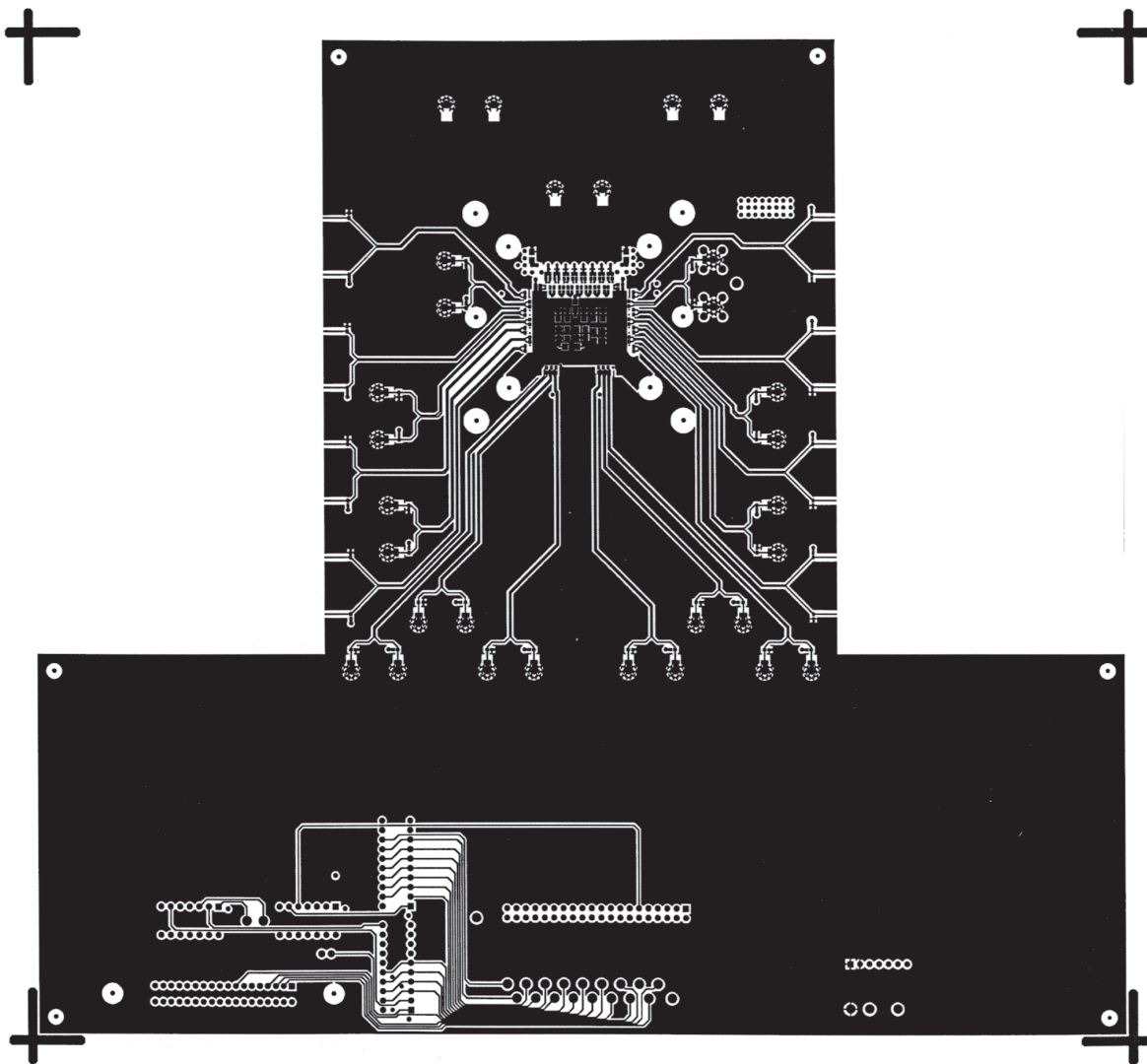

Figure 20. Circuit Side

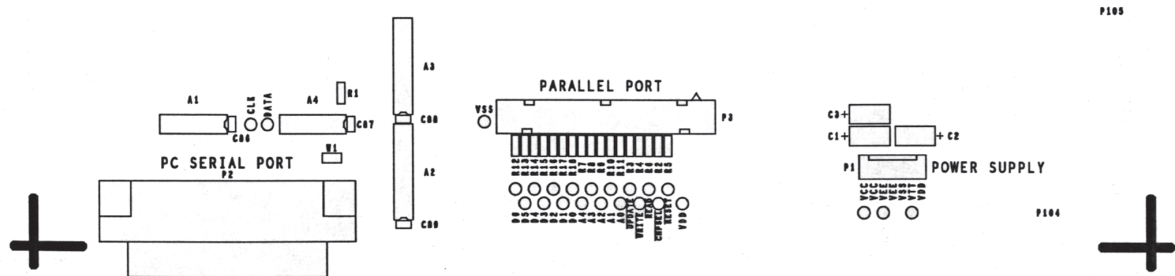
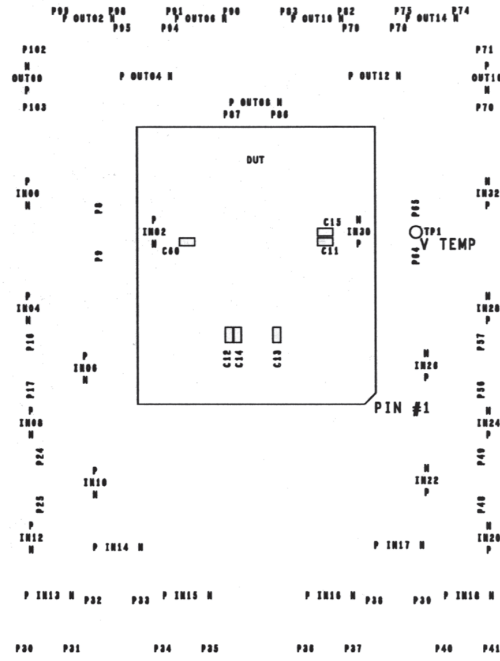

Figure 21. Silkscreen Top

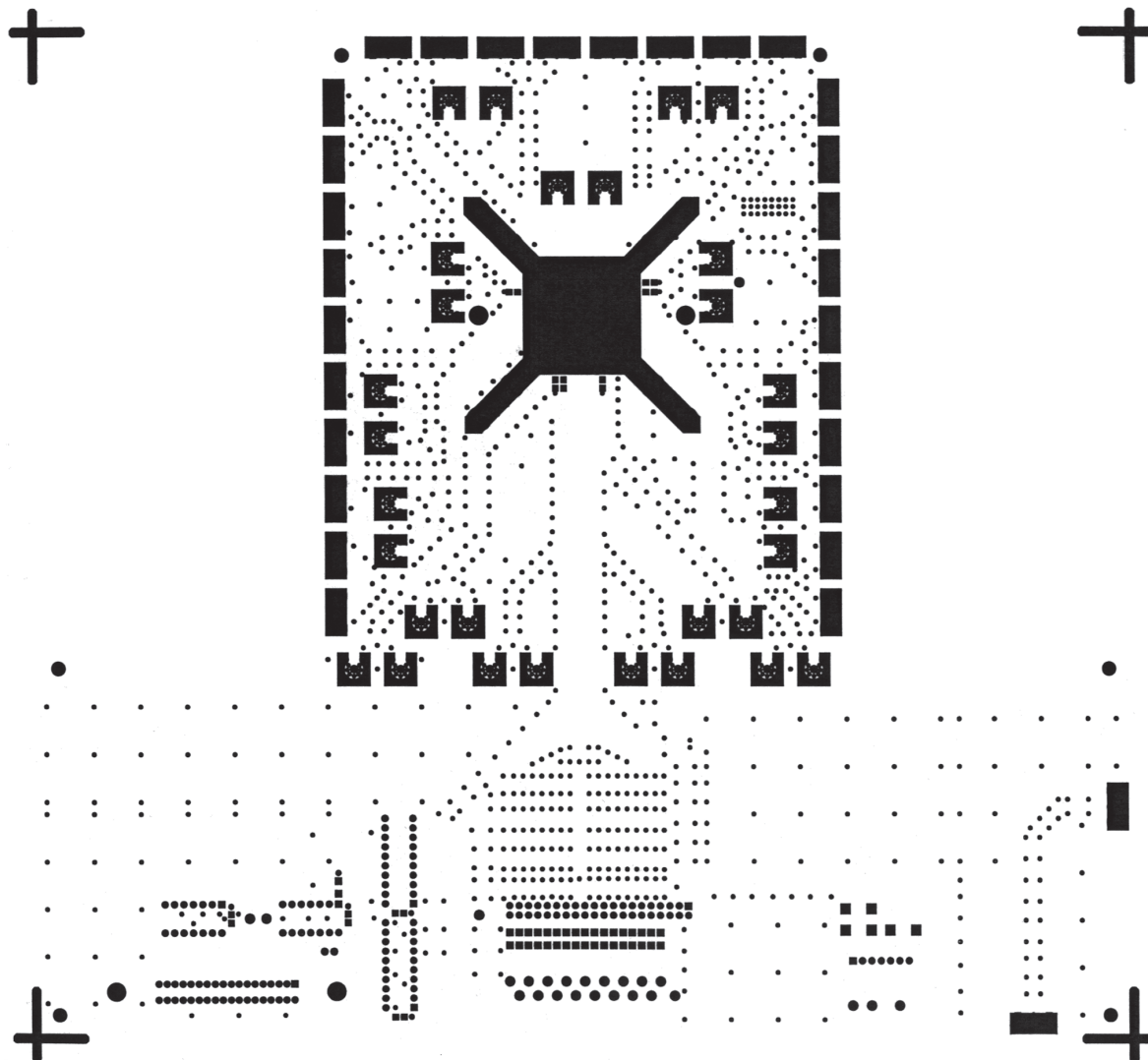

Figure 22. Soldermask Top

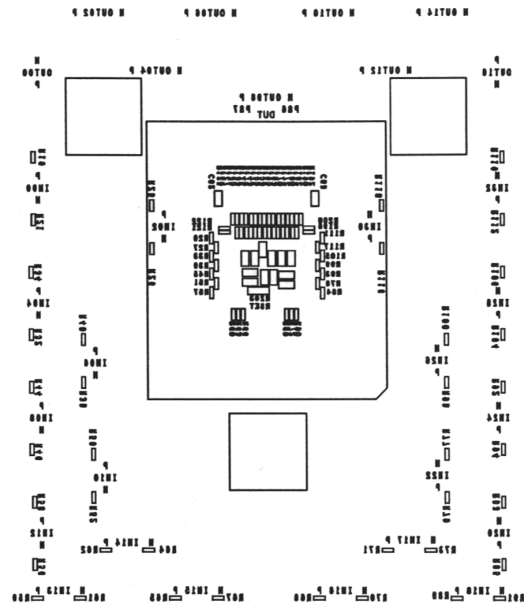

Figure 23. Silkscreen Bottom

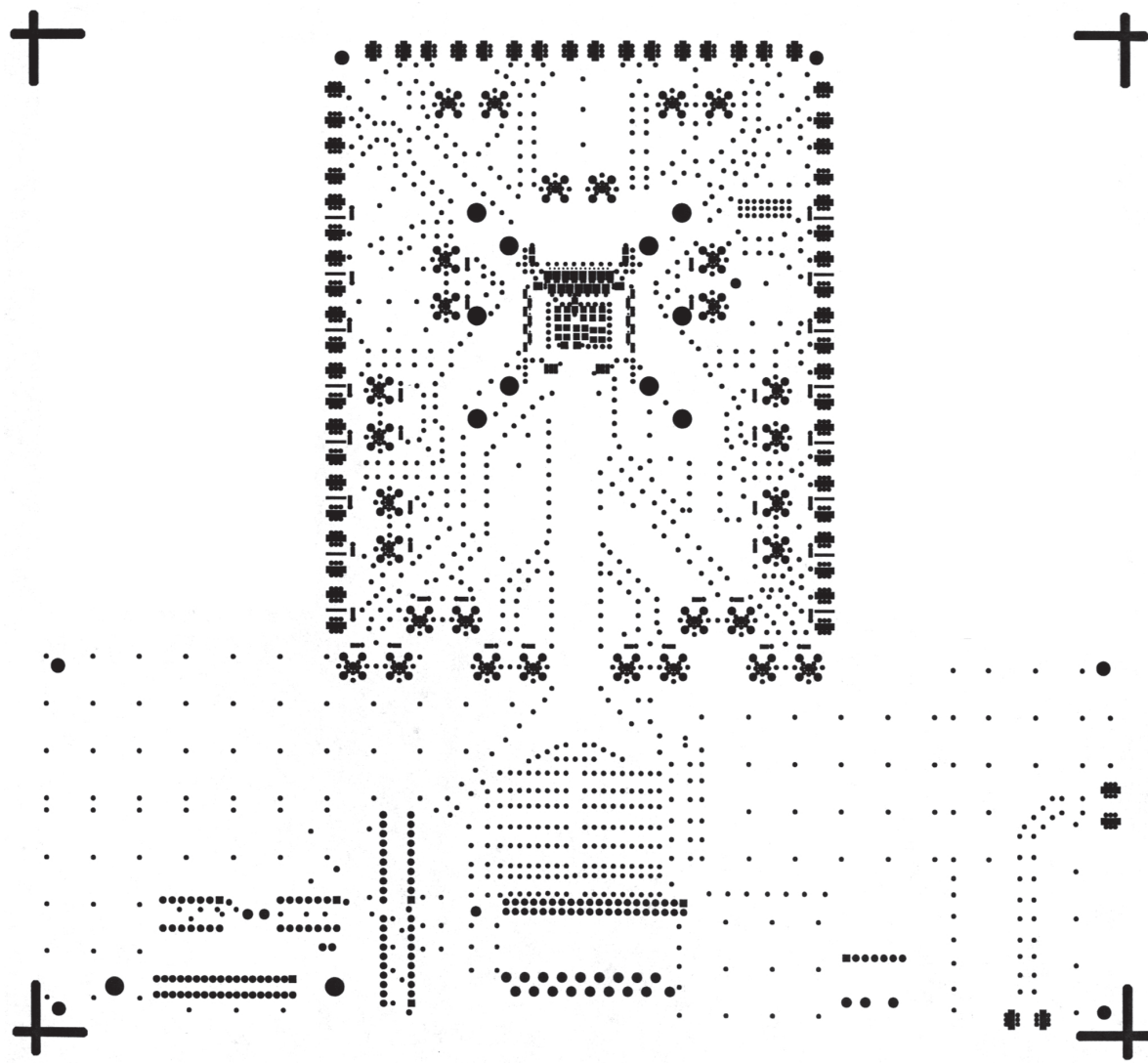

Figure 24. Soldermask Bottom

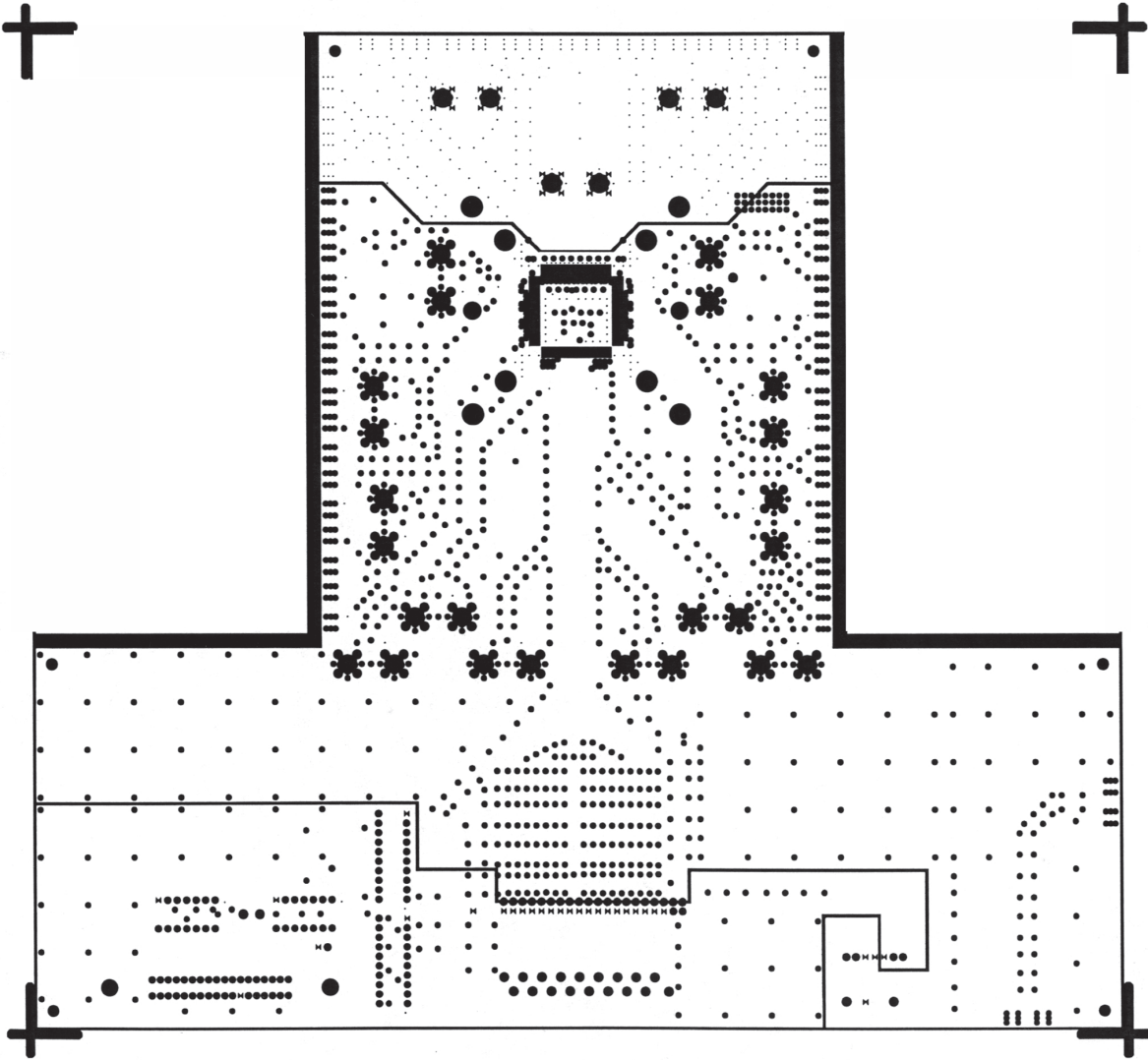

Figure 25. INT1 ( $V_{EE}$ )

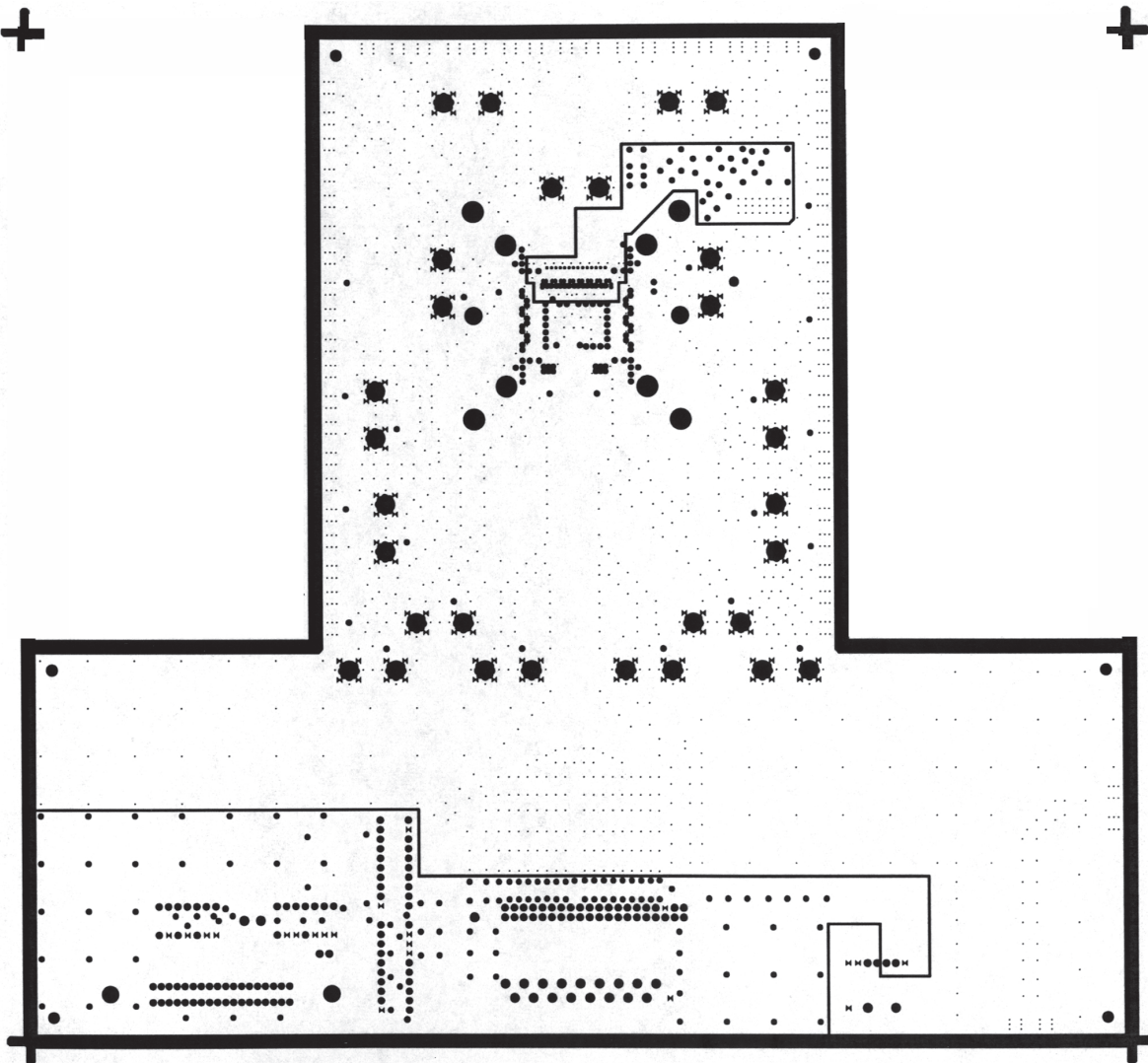

Figure 26. INT2 ( $V_{CC}$ )

# AD8151

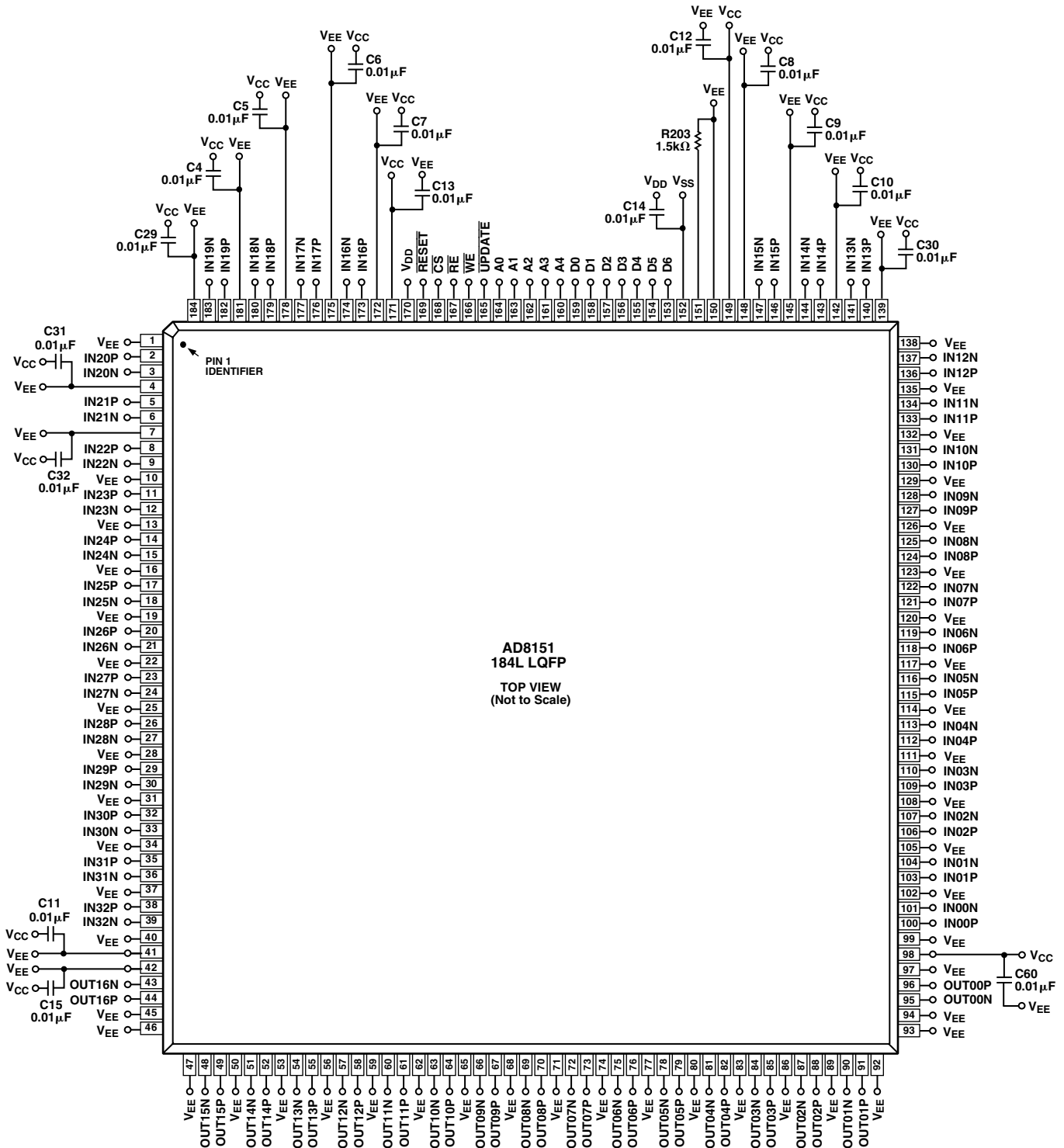

Figure 27. Bypassing Schematic



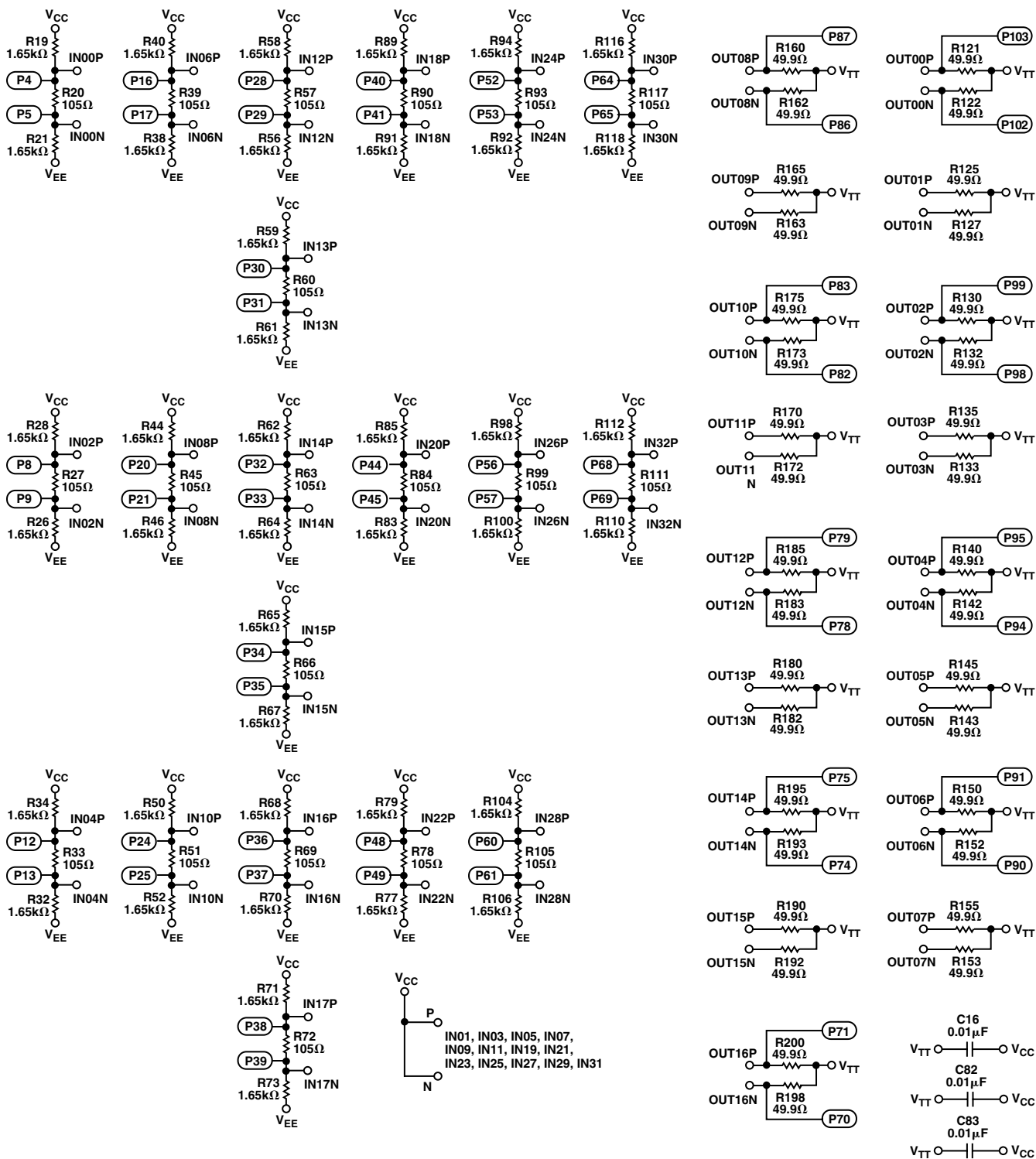

Figure 28. Evaluation Board Input/Output Schematic

# AD8151

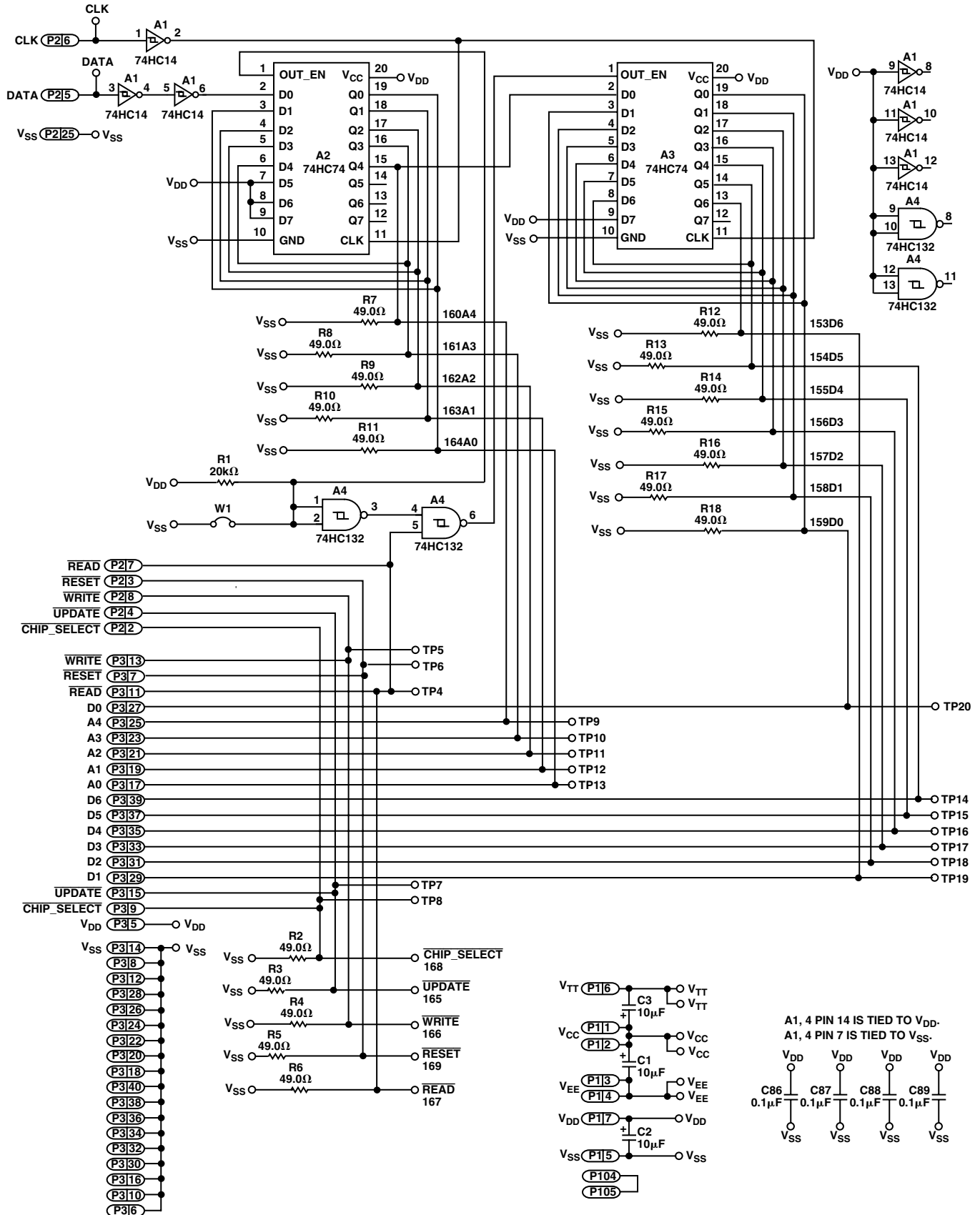
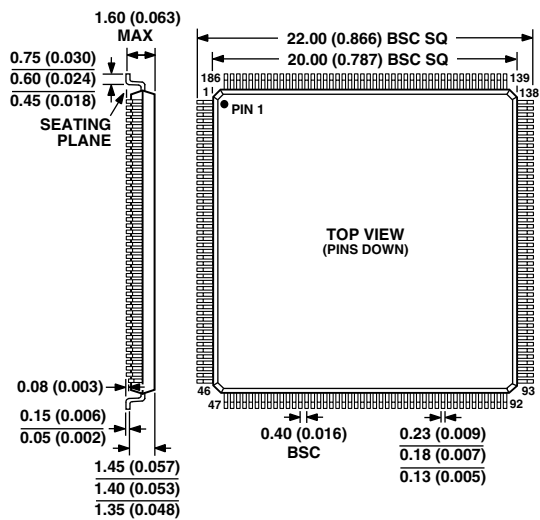

Figure 29. Evaluation Board Logic Controls

**OUTLINE DIMENSIONS**

Dimensions shown in mm and (inches).

**184-Lead Plastic LQFP  
(ST-184)**



CONTROLLING DIMENSIONS ARE IN MILLIMETERS

